

AC drive FUS E5/3E5/IP66 [0,37 – 18,5kW] 4.25

Features:

- U/f-characteristics control
- open loop vector control (150% start torque at 1Hz)
- safety stop and fire mode
- digital keypad with speed potentiometer
- built-in mains switch
- max. rotating field frequency 650Hz
- integrated braking chopper
- degree of protection IP66
- integrated mains filter
- integrated Modbus RTU
- controllable ventilator



AC drive
FUS E5/IP66 [0,37 – 2,2kW]
FUS 3E5/IP66 [0,75 – 18,5kW]



Function:

- control and setpoint entry via terminals, operating unit and bus systems
- PWM clock frequency 1 - 16kHz
- built-in SPS function
- potentialfree control and signalling contacts
- 150% overload for 60s
- integrated PI-controller

Typical Application:

electric pumps, heat pumps, vacuum pumps
ventilators and fans, travelling cranes, extraction systems
compressors, stirrers, centrifuges, saws
conveyors, woodworking machines
grinding machines, textile machines
packaging machines, printing machines
others

Options: (please see accessories)

- remote control / copying module
- keypad extension cable
- Profibus DP module
- TCP-IP module
- DeviceNet module
- CANopen module
- RJ45 to USB cable
- operating software

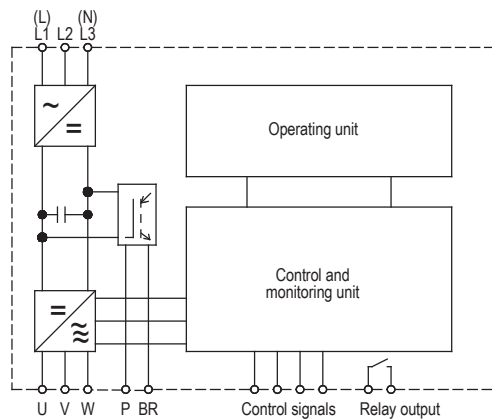

Typical designation	FUS ... /E5/IP66				FUS ... /3E5/IP66								
	037	075	150	220	075	150	220	400	550	750	1100	1500	1850
motor shaft power / kW	0,37	0,75	1,5	2,2	0,75	1,5	2,2	4	5,5	7,5	11	15	18,5
mains voltage according to DIN EN 50160 (IEC 38)	single-phase 200-240V, +10%, -15% 50/60Hz ±5%				three-phase 380-460V, +10%, -15% 50/60Hz ±5%								
output current / A	3,1	4,5	7,5	10,5	2,3	3,8	5,2	8,8	13	17,5	24	32	40
order number: 2T101. ...	23037	23075	23150	23220	40075	40150	40220	40004	40005	40007	40011	40015	40018

Technical data	FUS ... /E5/IP66				FUS ... /3E5/IP66										
	0,37	0,75	1,5	2,2	0,75	1,5	2,2	4	5,5	7,5	11	15	18,5		
motor shaft power / kW	0,37	0,75	1,5	2,2	0,75	1,5	2,2	4	5,5	7,5	11	15	18,5		
mains voltage according to DIN EN 50160 (IEC 38)	single-phase 200-240V, +10%, -15% 50/60Hz ±5%				three-phase 380-460V, +10%, -15% 50/60Hz ±5%										
output current / A	3,1	4,5	7,5	10,5	2,3	3,8	5,2	8,8	13	17,5	24	32	40		
control functions	0 – 599Hz														
frequency setting range	18 adjustable U/f-characteristics; open loop vector control														
torque boost	0 ... 3600s														
ramp-up and ramp-down time	potentiometer >= 1kΩ, 0-10V, 0/4-20mA, keypad, keypad potentiometer, fixed frequencies, motor potentiometer, Modbus RTU														
frequency setpoint	-10 ... 50°C, -40 ... 60°C														
ambient / storage temperature	-10 ... 50°C, -40 ... 60°C														
design size	1			2			1			2			3		
weight / kg	2,9			6			2,9			6			12,7		

Dimensions:

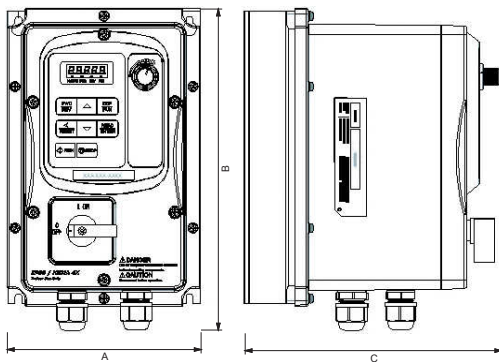

size	A	B	C
1	151	249	200
2	198	335	235
3	223	466	267

Alle dimensions indicated in mm

Connection Diagram:

