

Assembly- and Commissioning Instructions
Safety Standstill Monitor
VersiSafe

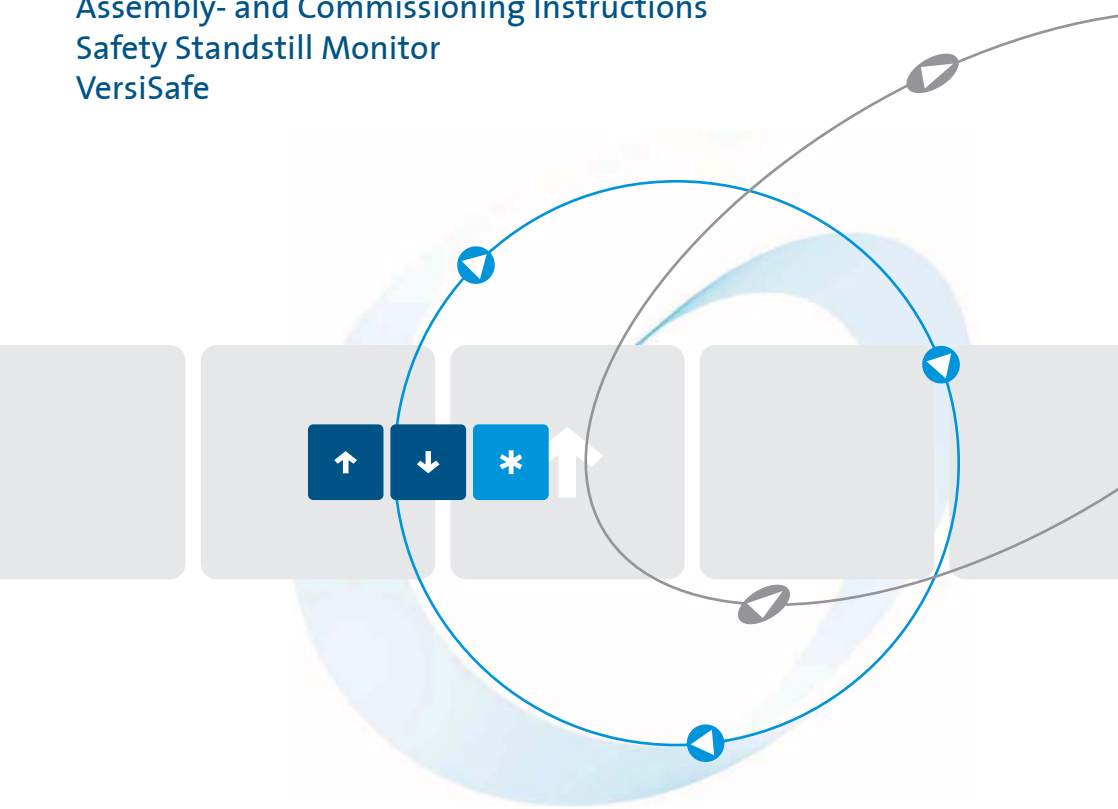

Quality is our Drive.

as per 09/18 17800.10001

Table of Contents	Page
1. Safety remarks	3
2. Conformity	3
3. EC Declaration of Conformity	4
4. Function	5
5. General description	6
5.1 Applications	6
5.2 Features	6
5.3 Funtion	6
5.4 Functional diagram	8
5.5 Functional description	8
6. Technical data	9
6.1 Input (L1 - L2 - L3)	9
6.2 Output	10
6.3 General data	10
6.4 Dimensions	14
6.5 Characteristics	15
7. Commissioning	15
7.1 Terminal connections	15
7.2 Setup and setting	16
7.3 Special applications and operation notes	17
8. Failure monitoring	19
8.1 Types of error	19
8.2 Failure indication	20
8.3 Failure treatment	21
9. Connection diagramm	24
9.1 with 3-phase motor	24
9.2 with single-phase motor	24
9.3 Typical connection combination with E-Stop	25
9.4 Typical connection combination with star delta timer, 2-channel connection of the measuring inputs	26
9.5 Typical connection combination with star delta timer, 3-channel connection of the measuring inputs	27

These commissioning instructions were prepared with great care. Nevertheless, PETER electronic GmbH & Co. KG does not assume liability for damage resulting from mistakes possibly contained in this manual. Technical changes that serve to improve the product are subject to change without notice.



Disposal Instructions

Equipment containing electrical components may not be disposed of together with domestic waste. It must be collected separately as electrical and electronic waste according to local and currently valid legislation.

Notes and symbols used in these instructions

Note: Notes explain the advantages of certain adjustments or settings and help you to make use of the device in the best possible way.



Warning notices: Read them carefully and follow them strictly!

Warning notices are indicated in order to protect you against danger or to help you to prevent the device from being damaged.



Caution: Danger to life through electric shock!

When you see this sign, always make sure that the device is de-energized and secured against unintentional energizing.

1. Safety remarks



Installation and setup of the VersiSafe must only be carried out by well trained staff, with knowledge about all relevant standards for safety, accident avoidance and control circuits. This manual must be read and understood before installation and setup.

The VersiSafe is suitable to operate as a part in safety circuits of a plant or machine. Usually also other components are part of these circuits. It is the liability of the builder of the plant or machine to guarantee the complete safety function by selecting the correct components, wiring and operation.

Also the correct tripping point and time delay setting of VersiSafe suitable for the application is in the liability of the user.

When stocking, transporting and operating the VersiSafe the conditions stated in the technical data must be observed. Defective units must not be operated. Opening a device or making unauthorised changes can influence the safety function and finish warranty.

When switching capacitive or inductive load over the output contacts appropriate protection should be provided in order not to overload the contacts. In addition a fuse must be provided to protect the contacts against welding (see technical data).

The unit should be panel mounted in an enclosure rated at IP 54 or superior. Dust and dampness may lead to malfunction



Risk of fire or other thermal hazards!

The device may only be used for the applications described in the mutually applicable operating instructions / data sheet. The notes in the respective documentation must be heeded. The permissible ambient conditions must be observed. In particular, the current limit curve must be heeded.

2. Conformity

In industrial linguistic usage the Safety Standstill Monitor of the type series VersiSafe are called "devices", however, in the sense of the "device-safety-law", the "EMC-law" or the "EC machinery directive" they are not devices or machines ready for use or connection but they are components. It is only possible to define their final function, when these components are integrated into the design and construction of the user.

To be able to use the devices to their intended purpose, it requires power supply networks according to DIN EN 50160 (IEC38).

The user takes the responsibility that the user's design and construction comply with the applicable legal provision.

The commissioning is strictly forbidden as long as the conformity of the final product with the guideline 2006/42/EC (Machinery directive) is not proved.

3. EC Declaration of Conformity



EC Declaration of Conformity

The manufacturer / company placing the product on the market
(authorized representatives of the manufacturer / companies placing the product on the market
that are established within the Community)

Name / Address: PETER electronic GmbH & Co. KG
Bruckäcker 9
92348 Berg

hereby declares that the following product (device, component, unit) in the version as supplied

Product designation: Standstill monitor
Series / type designation: VersiSafe
Article number: 278...
Year of manufacture: 2007

complies with the provisions of the following EU-directives:

2014/30/EU Electromagnetic compatibility
2006/42/EG Machinery Directive
2011/65/EU RoHS-Directive

The following harmonized standards have been applied:

Basis of Testing	EN ISO 13849-1:2015	IEC 62061:2005 + A1:2012 + A2:2015
	IEC 61800-5-1:2016	IEC 61800-5-2:2016
	IEC 61508 Parts 1-7:2010	
	EN 61000-6-1:2007	EN 61000-6-2:2005
	EN 61000-6-3:2007 + A1:2011	EN 61000-6-4:2007 + A1:2011
	EN 61000-6-7:2015	

This EC Declaration of Conformity is no longer valid, if the product is modified or changed
without our agreement.

This declaration is issued under the sole responsibility of the signatory.

Berg, 29.06.2018 Dr. Thomas Stiller, Managing director
(place, date) (signatory and function of the signatory)

(signature)

4. Function

The VersiSafe is connected to the motor terminals and measures the induced back emf voltage of a freewheeling motor. 2 redundant measuring channels are used (L2-L1 and L3 L1). If the back emf voltage drops to 0 simultaneously in both channels this indicates standstill and the output relay is energised.

To adopt the unit to all different types of motors and applications the voltage threshold indicating standstill on VersiSafe is adjustable. Also the time delay between detection and energisation of the relay is adjustable (standstill time t_s).

In addition the unit detects broken wire on the measuring inputs L1 / L2 / L3. If broken wire is detected the output relays goes into safe state (as with running motor). This state is stored and can be reset by bridging terminals X3-X2.

The input signals of both channels are permanently compared. If the signals are different for more then 2.5 sec a simultaneity failure isdetected. This failure resets when both input channels receive simultaneous signals with the same level.

To the terminals X1-X2 the feedback circuit of external contactors (used for contact reinforcement) is connected (NC contact). If no feedback circuit is required, these terminals must be linked. Open terminals will cause a failure message.

Circuit diagram

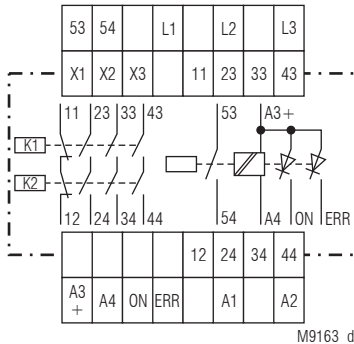

Warning:

The terminals X1 - X2 - X3 has no galvanic separation to the measuring circuit L1 - L2 - L3. They must be controlled with volt free contacts.

Indicators

green-red LED „UH“:	green on, when operation red on, with internal error
yellow-green LED „OUT“:	yellow on, at $EMK > U_{an}$ flashes green at time progression of t_s permanent on, when output contacts are enable
red LED „ERR“:	flashes at error in measuring and feedback circuit and low auxiliary voltage U_H (see flashing codes)

5. General description

5.1 Applications

Safe standstill detection on 3- and single-phase motors, e.g. to enable gate interlocks on machine tools or to activate hold in brakes.

5.2 Features

- According to
 - Performance Level (PL) e and category 4 to EN ISO 13849-1
 - SIL-Claimed Level (SIL CL) 3 to IEC/EN 62061
 - Safety Integrity Level (SIL) 3 to IEC/EN 61508 and IEC/EN 61511
- Safe standstill detection on 3- and single-phase motors
- No external sensors necessary
- Independent of direction
- Broken wire detection
- Forcibly guided safety contacts: 3 NO contacts, 1 NC contact for AC 250 V
- 2 semiconductor monitoring outputs
- 1 monitoring output (NO contact)
- Adjustable voltage setting
- LED indicators for standstill, event of line breakage and operation voltage
- Suitable for operation with inverters
- Width 45 mm

5.3 Function

The VersiSafe can be used for standstill detection on all 3-phase, single phase and DC motors, that generate a voltage caused by remanence when freewheeling. As the voltage level U_{an} for standstill monitoring and the time delay t_s , after detection of standstill until the safety relays are switched on, are adjustable, the function can be adopted to different motors and applications.

Terminals and settings

L1 - L2 - L3:	connection to monitored motor
11 - 12:	safety contacts (NO)
23 - 24, 33 - 34, 43 - 44:	safety contacts (NC)
53 - 54:	monitoring contact (C/O)
X1 - X2:	connection of feedback circuit (for external contactors)
X2 - X3:	manual reset for external faults
A1 - A2:	auxiliary supply (U_H)
A3(+) - A4:	supply for semiconductor outputs
ON:	semiconductor output indicates state of safety contacts
ERR:	semiconductor output indicates failures
Poti „ U_{an} “:	adjustment of voltage level for standstill detection
Poti „ t_s “:	adjustment of time delay before activation of safety contacts

Attention:

The outputs 53-54, ON and ERR are only monitoring outputs and must not be used in safety circuits!

5.4 Functional diagram

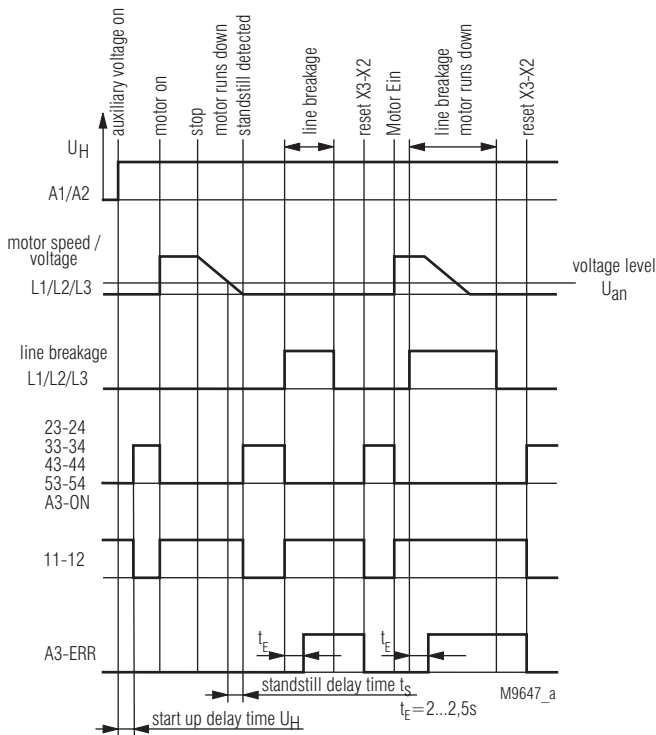

5.5 Functional description

The auxiliary voltage is connected to the terminals A1-A2; the LED „UH“ lights up green. On undervoltage or missing auxiliary supply the safety outputs are disabled. If semiconductor monitoring outputs are used, their supply voltage must be connected to A3(+)-A4.

A motor connected to the terminals L1-L2-L3 of the VersiSafe generates a voltage when running down (motor is switched off). The voltage is proportional to the speed and caused by residual magnetism (remanence).

This voltage is measured redundant on 2 input channels via the terminals L2 and L3 with L1 as common reference.

If the voltage drops on both channels below the adjusted value U_{an} , the unit detects standstill. When the terminals X1-X2 of the feedback circuit are bridged and the time delay t_S is finished, the safety contacts 23-24, 33-34 and 43-44 close while contact 11-12 opens. All 4 contact paths have 2 positive guided contacts of 2 safety relays wired in series.

At the same time the monitoring relay energises (53-54 closes), the semiconductor output „ON“ is switched on and the LED „OUT“ lights green. During time delay t_s this LED flashes.

If the voltage measured on terminals L1-L2-L3 of VersiSafe rises over the adjusted value plus hysteresis in at least one channel (the motor is switched on or the shaft turns mechanically), the positive guided output contacts are switched off immediately (contacts 23-24, 33-34 and 43-44 open while contact 11-12 closes). The monitoring relay de-energises (53-54 opens), the semiconductor output „ON“ goes off and the LED „OUT“ lights yellow (= U_{an} over adjusted value).

Feedback circuit X1 - X2

If the safety contacts control external contactors/components (e.g. to re-enforce or multiply the contacts) the safety function of them must be monitored. This is done with the feed back circuit (terminals X1-X2) to which the NC contacts of the contactors/components must be connected. (see also wiring diagrams).

The VersiSafe will only enable its safety output if the feedback loop X1-X2 is closed while standstill is detected, i.e. the external contactors/components are in initial state (NC contacts are closed).

The feedback circuit X1-X2 must be closed as long as the safety outputs (because of running motor or external failure) are not enabled. If not the failure „feedback circuit“ is indicated.

If the feedback circuit is not used, the terminals X1-X2 must be bridged.

6. Technical data

6.1 Input (L1 - L2 - L3)

Measuring-/Motor voltage:	max. AC 690 V
Input resistance:	500 kOhm
Response value U_{an}:	20 mV ... 400 mV, adjustable special variant 0,2 ... 4V

Response value dependent on frequency

Input frequency (Hz):	50	100	200	400	600	1k	1,5k	2k
Multiplication factor for U_{an} :	1,0	1,1	1,2	1,5	2,0	2,8	5	8

Hysteresis (for detection of running motor):	100 %
Release delay for detection of running motor:	< 100 ms
Standstill time delay t_s:	0,2 ... 6s adjustable
Auxiliary voltage U_H (A1 - A2):	AC 230 V, AC 400 V, DC 24 V
Recommended fusing:	2 A
Voltage range	
AC:	0,8 ... 1,1 U_N
DC:	0,9 ... 1,2 U_N
Nominal consumption:	5 VA, 3 W

Nominal frequency (AC):	50 / 60 Hz
Frequency range (AC):	45 ... 65 Hz
max. residual ripple (DC):	10 %
Start up delay when connecting U_H at standstill:	0,4 ... 0,8 s + adjustable t_s

6.2 Output

Contacts

(saftey contacts)

VersiSafe 230VAC: 3 NO contacts, 1 NC contact

The NC contacts 11-12 can only be used for monitoring.

Contact type: relay, positive guide

Nominal output voltage: AC 250 V

Thermal current I_{th} : 5 A (bis 40°C)

Quadratic total current: see derating curve

Switching capacity

to AC 15

NO contact: AC 3 A / 230 V IEC/EN 60 947-5-1

NC contact: AC 1 A / 230 V IEC/EN 60 947-5-1

to DC 13: DC 1 A / 24 V IEC/EN 60 947-5-1

Electrical contact life

to 5 A, AC 230 V $\cos \phi = 1$: 2×10^5 switching cycles

Fusing of the

saftey contacts:

max. fuse rating 4AgL
line circuit breaker C6A

Max. operating frequency:

1200 / h

Mechanical life:

=> 50×10^6 switching cycles

Semiconductor monitoring

output:

100 mA DC 24 V, plus switching,
galvanic separation; supply via
A3+ / A4 for output; „ON“ and „ERR“

NO monitoring contact:

3 A AC 250 V (closed when enabled)

6.3 General data

Nominal operating mode:

continuous operation

Temperature range

operation:

- 25 ... + 60°C

(+ 40°C with max. contact current, see Derating)

storage:

- 40 ... + 75°C

Clearance and creepage distance

rated impuls voltage/pollution degree:

IEC 60 664-1

Contacts 11/12, 23/24,

33/34, 43/44 against all others:

6 kV / 2

Contacts 11/12, 23/24, 33/34, 43/44 against each others:	4 kV / 2	
Indicator contact 53/54 against all others:	4 kV / 2	
Semiconductor outputs A3+/ ON / ERR / A4 against all others:	6 kV / 2	
Auxiliary voltage A1 / A2 against all others		
at auxiliary voltage AC:	6 kV / 2	
at auxiliary voltage DC:	4 kV / 2	
Control terminal X1 / X2 / X3:	no galvanic separation to L1 / L2 / L3	
EMC	IEC/EN 62 061	
Interference suppression		
Auxiliary voltage AC:	limit value class B	EN 55 011
Auxiliary voltage DC:	limit value class A*)	EN 55 011
*) The device is designed for the usage under industrial conditions (Class A, EN 55011). When connected to a low voltage public system (Class B, EN 55011) radio interference can be generated. To avoid this, appropriate measures have to be taken.		
Degree of protection		
Housing:	IP 40	IEC/EN 60 529
Terminals:	IP 20	IEC/EN 60 529
Enclosure:	thermoplastic with VO behaviour according to UL subject 94	
Vibration resistance:	amplitude 0,35 mm frequency 10 ... 55 Hz	IEC/EN 60 068-2-6
Climate resistance:	25 / 060 / 04	IEC/EN 60 068-1
Terminal designation:		EN 50 005
Wire connection:		DIN 46 228-1/-2/-3/-4
Screw terminals (integrated):	1 x 4 mm ² solid or 1 x 2,5 mm ² stranded ferruled or 2 x 1,5 mm ² stranded ferruled or 2 x 2,5 mm ² solid	
Insulation of wires or sleeve length:	8 mm	
Wire fixing:	Plus-minus terminal screws M 3,5 box terminal with wire protection or cage clamp terminals	
Mounting	DIN rail	IEC/EN 60 715
Weight:	approx. 400 g	

Safety related data**Values according to EN ISO 13849-1:**

Category:	4	
PL:	e	
MTTF _d :	93	a
DC _{avg} :	99,0	%
d _{op} :	365	d/a (days/year)
h _{op} :	24	h/d (hours/day)
t _{Zyklus} :	28,8E+03 s/Zyklus	
	= 1	/8 h (hours)

Values according to IEC EN 62061 / IEC EN 61508 / IEC EN 61511:

SIL CL:	3	IEC EN 62061
SIL:	3	IEC EN 61508 / IEC EN 61511
HFT*:	1	
DC:	99,0	%
PFH _D :	4,10E-10	h ⁻¹
T1:	20	a (years)

*)HFT = Hardware-Failure Toleranz

Demand to our device based on the evaluated necessary safety level of the application		Intervall for cyclic test of the safety function
acc. to EN ISO 13849-1	PL e with Cat. 3	once per month
	PL d with Cat. 3	once per year
acc. to IEC/EN 62061, IEC/EN 61508	SIL CL 3, SIL 3 with HFT = 1	once per month
	SIL CL 2, SIL 2 with HFT = 1	once per year
acc. to EN 61511	SIL 3	once per year

Info: The values stated above are valid for the standard type.
 Safety data for other variations are available on request.
 The safety relevant data of the complete system has to be determined by the manufacturer of the system.

UL -Data

The safety functions were not evaluated by UL. Listing is accomplished according to requirements of Standard UL 508, „general use applications“.

Measuring-/Motor voltage: max. AC 600V

Ambient temperature: -25 ... +60°C, (+40°C with max. contact current, see Derating)

Switching capacity

safety contacts

(11/12, 23/24, 33/34, 43/44)

Ambient temperature 40°C:

Pilot duty B300
5A 250VAC G.P.
5A 24VDC G.P.

Ambient temperature 60°C:

Pilot duty B300
2A 250VAC G.P.
2A 24VDC G.P.

Switching capacity

indicator contact (53/54):

3A 250VAC G.P.

Wire connection:

Fixed screw terminal:

60°C / 75°C copper conductors only
1x AWG 20 - 12 Sol/Str Torque 0.8 Nm or
2x AWG 20 - 14 Sol/Str Torque 0.8 Nm

Device with auxiliary voltage Uh 24V DC:

Device must be supplied with a Class 2 or a Voltage / Current limited Power Supply.

Info: Technical data that is not stated in the UL-Data, can be found in the technical data section.

6.4 Dimensions

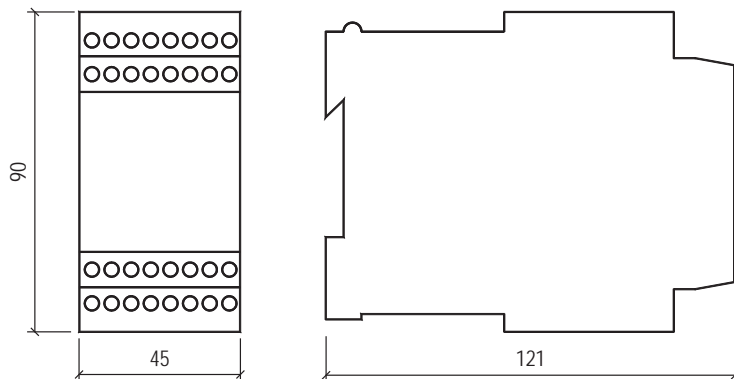

All dimensions in mm.

Standard type

VersiSafe

AC 230 V 50/60 Hz

Article number:

27800.69000

- Safety output: 3 NO contacts, 1 NC contact
- Auxiliary voltage U_H : AC 230 V
- Response value U_{an} : 20 ... 400 mV
- Standstill time t_s : 0,2 ... 6 s
- 1 semiconductor and 1 NO contacts for indicator output
- 1 semiconductor for fault indicator output
- Width: 45 mm

6.5 Characteristics

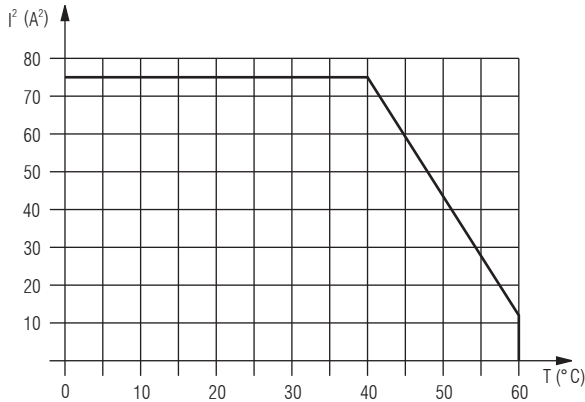

Quadratic total current

$$= I_1^2 + I_2^2 + I_3^2$$

I_1, I_2, I_3 - current in contact paths

max. permitted current up to 40 °C on 3 contact paths = 5A

$$(5^2 + 5^2 + 5^2 = 75A^2)$$

max. permitted current up to 60 °C on 3 contact paths = 2A

$$(2^2 + 2^2 + 2^2 = 12A^2)$$

M9658

Derating curve for contact currents of safety contacts

7. Commissioning

7.1 Terminal connections

The VersiSafe has to be connected according to connection examples or in a similar way. The connection of DC- motors is made as with single phase AC-motors.

L1 - L2 - L3

The measuring wires L1-L2-L3 have to be connected directly to the windings of the monitored motor (not via transformers) in order to provide a correct broken wire detection for the connection wires and motor windings.

The motor windings must not be disconnected from the measuring wires by motor contactors, because broken wire detection is activated and standstill monitoring is disabled.

Interference to the measuring wires should be avoided as no standstill may be detected by the VersiSafe. If possible the measuring wires should be run separately from the motor wires or screened wires should be used. In this case the screen can be connected at the motor side.

A 1 - A2

Connection of the auxiliary supply, recommended fuse : 2A.

A3+ / A4

DC 24 V supply (12 ... 30 V) for the semiconductor monitoring outputs „ON“ and „ERR“, if these are used.

11-12, 23-24, 33-34, 43-44

Safety output contacts, connection according to the connection examples or similar.

Recommended fuse: 5 A fast acting, to avoid welding of the contacts in the case of external wiring or component failures. See also technical data.

53 - 54

Monitoring contact to indicate the state of the safety output (non safety contact).

X1 - X2 (feedback circuit)

Connection of NC contacts of external components or contactors for contact re-enforcement, must be linked if not used.

X2 - X3

Connection for manual or auto reset, connection is made according to the required application. When monitoring DC motors or in the case of DC-braking the broken wire / offset failure will be shown during operation.

In this case the terminals must be linked because if storing the failure would not allow activation of the safety contacts at standstill.

Attention:

The terminals X1-X2-X3 have electrical connections to the measuring inputs L1-L2-L3. Volt free contacts must be used for bridging. If terminal 3 should be controlled by a PLC via an interface relay this must have the necessary insulation between the motor voltage (measuring input) and PLC potential.

7.2 Setup and setting**Preparation**

- Motor on standstill
 - Terminals L1-L2-L3 connected to the motor windings
 - Provide link on terminals X1-X2
 - Provide also link on X2-X3 on DC motors or DC braking
 - Adjust U_{an} to minimum (20 mV)
 - Adjust t_s to minimum (0,2 s)
-

Connect correct auxiliary voltage to terminals A-A2

==>After 1 sec the LEDs „UH“ and „OUT“ light up green and the safety contacts are switched on. Also the monitoring relay and the semiconductor output „ON“ must be activated.

If standstill is not detected (LED „OUT“ lights yellow), possibly interference is coupled on the measuring circuit. Adjust U_{an} higher or screen the measuring wires.

Start of motor

==>LED „OUT“ changes colour to yellow. The output relays and the semiconductor output „ON“ switch off. On DC motors the LED „ERR“ starts to flash after 2 s with flash code 2 and the output „ERR“ comes on.

Stop of motor - run down or DC braking

The speed at which standstill is detected (yellow LED „OUT“ changes to green/green flashing) can be adjusted on Potentiometer „ U_{an} “. When the run down is very slow or irregular the time delay must possibly be increased to avoid switching on and off of the output relays. Possibly this effect can also be avoided by slightly increasing U_{an} . During time delay t_s the LED „OUT“ flashes green.

If standstill detection shall only take place at very low speed of the motor, U_{an} is set normally to minimum. By increasing the delay time t_s a possible pulsing of the output relays can be avoided. A longer time delay will also guarantee standstill detection only when the motor has already stopped turning. (especially on motors that generate only a small remanence voltage).

On slow decrease of motor speed it is possible that a simultaneity failure occurs (see failure monitoring) when the measuring channels reach the tripping values slowly and not within 2.5 sec. To avoid this failure a single phase connection could be the solution (to make sure that both inputs get the same signal) or the increase of the setting value U_{an} .

If the run down time of the motor is short t_s can be set to a minimum (0.2 s). This is suitable in production systems to shorten machine cycles.

**Warning:**

It is the responsibility of the user to adjust U_{an} and t_s in a way that standstill detection and enabling of the safety contacts in the application is only possible when danger to men and material by the rotating can be excluded.

7.3 Special applications and operation notes**Motors with switched windings**

(e.g. star delta starters, reversing circuits, multi speed motors)

With these applications please make sure, that the measuring inputs must be linked via the motor windings. An open connection will result in broken wire indication and disable the safety contacts. When connecting the VersiSafe to a 3-phase motor with star delta starter the star contactor must be energised while the motor is switched off, in order to achieve closed circuits between L1-L2-L3 via the motor windings.

If it is not possible to switch in the star contactor after the motor is switched off, the measuring inputs of the VersiSafe have to be connected like a single phase connection. L2-L3 are bridged and connected to one end of a motor winding and L1 to the other end of the same winding.

For reversing circuits and multi speed motors please follow the same procedure.

If in a 3-phase connection of VersiSafe windings are switched over, and the interruptions of the measuring circuits are longer then 2 s, the standstill monitor detects broken wire. In order not to store this failure, the unit should work with auto reset.

Operation with DE motors

The VersiSafe can be used on DC motors if these generate a remanence voltage during run down.

The connection is made similar as with a single phase motor.

As the remanence voltage in this case is normally a DC voltage the unit will detect a broken wire / offset failure and indicate it on LED „ERR“ and semiconductor output „ERR“. Taking this in mind and operating the unit with auto reset for these failures the unit can be used for safety standstill monitoring.

Operation with electronic motor controller

(inverters, DC-brakes)

The operation of VersiSafe to detect standstill on motors with electronic motor control is possible if the control units do not generate any voltage n standstill. (NO position control on inverters, no DC voltage on brakes after standstill).

If the inverter produces a DC offset or a DC brake is active, an offset or broken wire failure is indicated on LED „ERR“ and semiconductor output „ERR“. This error resets automatically if on terminals X2-X3 automatic reset is selected.

When there are inverters in the installation it is recommended to use screened measuring wires to the motor. The screen can be connected to the motor.



Attention

If the motor current is run down by inverters or softstop modules in a slow way the motor may be de-magnetised. It is necessary to check if the remaining remanence voltage is sufficient to guarantee a correct and safe standstill monitoring. At high frequencies an increasing damping of the measuring inputs has to be taken into account (see technical data Measuring input „response value dependant on frequency“).

8. Failure monitoring

8.1 Types of error

The VersiSafe includes a number of facilities to detect failures that could influence the safety function of the module. The failure check is carried out on power up of the unit and in cycles during normal operation.

If a failure occurs the output relays switch off. The failure state is indicated with the LEDs „ERR“ and „UH“ and the semiconductor output „ERR“ switches on.

With safety relevant failures the unit differentiates between external failures (broken wire / offset, simultaneity failure, feedback circuit failure) and internal failures.

Broken wire / offset failures and feedback circuit failures can be stored or automatic reset after removing the fault. (see chapter failure storing).

Broken wire / offset

The connection wires between VersiSafe and motor are continuously monitored for broken wire and on a DC-voltage offset higher than U_{an} .

In the case of a broken wire or offset failure the output relays are switched off immediately and the LED „OUT“ lights yellow.

In addition a failure signal comes up with delay (on broken wire after 2s on offset failure after 8 s): the semiconductor output „ERR“ switches on and the LED „ERR“ flashes with failure code 2 or 3 depending on the failure located either between L1-L2 or L1-L3.

Simultaneity of the measuring signals

As additional safety feature the 2 input signals (L2 and L3) are compared continuously. This allows to detect also internal failures in one measuring channel.

If the signals are different for at least 2.5 s (one channel $>U_{an}$ the other $<U_{an}$) simultaneity failure is detected. The semiconductor output „ERR“ is switched on and the LED „ERR“ flashes with failure code 5.

If the measured signals return to the same level $<U_{an}$ the error remains stored and the outputs are disabled.

The simultaneity failure is only reset when both channels return to $> U_{an}$. If after that both channels drop below the setting value, get $< U_{an}$ the out relays will switch on.

Failure in feedback circuit X1-X2

As already mentioned the failure code „feedback circuit“ occurs when the outputs are disabled and there is no connection between terminal X1-X2. The semiconductor output „ERR“ is switched on and the LED „ERR“ flashes with failure code 4.

Also when both input signals drop now to $<U_{an}$ and besides the open feedback loop no other failures are present the feedback circuit failure remains active and the outputs remain disabled.

If the feedback circuit is now closed and the unit is on auto reset for external failures (see failure storing) the output relays are enable and switch on.

Potentiometer error

To achieve the required safety when adjusting the voltage threshold for standstill detection, each setting function is realised with 2 potentiometers having one common setting knob. If on 2 corresponding potentiometers a different setting is detected the potentiometer error U_{an} or t_s is displayed.

To remove the failure please try to readjust the potentiometer. Please make sure that you feel the detent.

Internal device failure

Internal failures are always stored, independent of the reset input X3 and cause the output relays immediately to switch off, the semiconductor output „ERR“ to switch on and the LED „UH“ to change its colour from green to red.

Examples for internal failures:

- Failure on safety relays e.g. welded output contacts
- Internal failures on measuring channels and measuring circuits
- Internal failures on control circuits for the safety relays
- failures on setting potentiometers for U_{an} and t_s
- Undervoltage failure (LED „ERR“ flashes with failure code 1)

8.2 Failure indication

Failure indication with flash code of LED „ERR“

The flash codes indicate failures caused externally (see diagram on first page).

A series of flash pulses 1-5 followed by a slightly longer space is displayed. The flash code indicates the type of failure. If several failures are present at the same time only the failure with the highest priority (lowest flash code) is shown. When this failure is removed the other existing failures are displayed in the same way according to their priority.

Failure storing / reset (terminals X2-X3)

With the external failures broken wire/offset and feedback circuit the operator can choose between manual and automatic reset after the failure is removed.

X2-X3 open:	manual reset
X2-X3 closed:	automatic reset

Attention:

The a.m. storing function of the external failures broken wire /offset, and feedback circuit is not a safety function. I.e. in respect to safety aspects it can not be regarded as guaranteed. The reset for these failures must be therefore regarded as auto reset after removing the faults.

Internal device failures that could occur in seldom cases (e.g. caused by temporary interference) can be reset by switching the supply voltage off and on. If a reset is not possible also if the voltage is applied correctly, the device could be defective and should be sent back to the manufacturer for examination or repair.

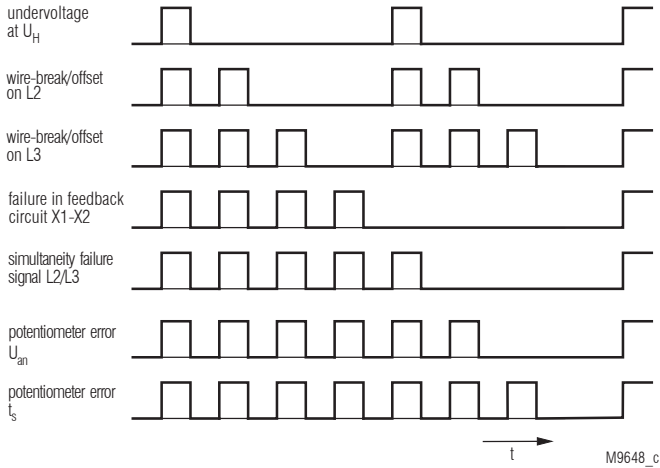

8.3 Failure treatment

Failure:

The unit enables the safety outputs while the motor is still turning (LED OUT^u lights green).

Solution:

Reduce setting of U_{an} if necessary to minimum. If the outputs are still enabled a wiring problem on the measuring wires could be the reason (short circuit on terminals L2/L3 to L1) or the motor generates only a very low remanence voltage. Please check connection of measuring inputs to motor winding according to the connection examples.

Failure:

The output contacts are enabled to early (motor has not finally stopped):

Solution:

Adjust setting value U_{an} to lower level. Additionally the delay time t_s could be increased.

Failure:

Output contacts remain disabled while the motor is already on standstill

Solution:

Observe status of indicator LEDs:

1. LED „UH“ lights green?

If **yes**, go to 2.

If **no**, U_H has undervoltage or the unit has an internal device failure.

(Internal failures can occur in the case of undervoltage, welded safety output contacts or seldom because of interference)

==> switch supply voltage off and on. If the failure still exists in spite of correct auxiliary supply UH the unit could be defective and has to be sent to manufacturer for test or repair.

2. LED „ERR“ (red) flashes with code 1?

If **no**, go to 3.

If **yes**, the unit has detected undervoltage

==> Apply correct auxiliary voltage

3. LED „OUT“ flashes green?

If **no**, go to 4.

If **yes**, standstill is detected, but the time t_s till enabling of the outputs is not elapsed.

==> wait till time t_s is finished.

If after 6 s the outputs are not enabled, the measuring input L1-L2-L3 receives intermittent voltage peaks that are higher than U_{an} .

This should normally be indicated by intermittent yellow flashes on the LED).

==> Adjust U_{an} to a higher value, clear interference on measuring wires (use screened cables).

4. LED „OUT“ lights yellow?

If **yes**, the voltage on the measuring input is higher than the adjusted value U_{an} ; go to 5.

If **no**, LED is off

Standstill is detected (voltage on measuring input is $<U_{an}$) but the outputs are not enabled because

- a) Feedback circuit X1-X2 is not closed or
- b) a simultaneity failure occurred (see failure monitoring) or
- c) a previous failure (broken wire / offset, feedback circuit) is still stored (terminals x2-x3 are not linked).

The type of failure is indicated by flash code on the red LED „ERR“:

- a) flash code 4 (feedback circuit not closed)
- b) flash code 5 (simultaneity fault of the measuring signals on L2 L3)
- c) code 2, 3 or 4 depending on priority and failure.

==> - close feedback circuit

- Bridge terminals X2-X3 (manual reset)

If now still the simultaneity failure (flash code 5 on LED „ERR“) is indicated it can be reset by switching the auxiliary supply off and on. The reset also takes place, when both input signals rise above U_{an} e.g. when starting the motor. If the simultaneity failure remains active after start of the motor (e.g. because of short circuit between L2-L1 or L3-L1) the wiring of the measuring circuit has to be checked according to the connection example.

If the simultaneity failure occurs often e. g. on slow decrease of the motor speed, the problem can be solved by increasing the tripping value U_{an} or/and by making a single phase instead of a 3-phase connection of the measuring circuit to the motor.

5. LED „OUT“ lights yellow while the motor is on standstill
If the yellow LED „OUT“ is on this indicates that the measuring inputs still receive an input signal higher than the adjusted value U_{an}

Observe in addition the LED „ERR“:

- a) if it stays off after a time of 8 s the problem could be a interference or residual voltage (induced AC voltage) on the measuring inputs
=> Increase the setting of U_{an}
If this shows no result, or if an increase is not wished, the interference to the measuring lines must be reduced e.g. by creening, shortening or separating the wires, Test: Disconnect motor and short circuit terminals L1-L2-L3 on the unit, the yellow LED must change to green or green flashing.
- b) if the red LED flashes code 2 the unit has detected broken wire or DC voltage offset between the measuring inputs L1 and L2 (or between L1 and L2 and L1 and L3).
- c) if the red LED flashes code 3 the unit has detected broken wire or DC voltage offset on measuring input L3

In the 2 last cases the wiring between VersiSafe terminals L1-L2-L3 and the motor terminals has to be checked on interruption. Possibly the interruption comes from disregarding the operating remarks for motors with switchable windings (see remarks).

If failures by interruption of the input circuits can be excluded the failure can result from a DC voltage offset $> U_{an}$. This can come from motor ontrrollers like inverters or DC brakes that are not completely switched off and supply a DC-voltage to the measuring circuit (check with Voltmeter).

If the DC content is only minor, the failure can be removed by increasing the setting value U_{an} . The yellow LED „OUT“ must change to green or green flashing. If not the motor controllers must be switched off in a way that standstill can be detected correctly.

Failure:

While motor is on operation a failure is indicated.
If the LED „UH“ lights red, an internal failure occurred.

Solution:

Switch auxiliary supply off and on again (see 1.)

If the LED „ERR“ indicates a failure the flash code shows the type of fault and how to remove it. Flash code 2 or 3 are normal during operation of DC motors. If the terminals X2-X3 are bridged, The failure is reset automatically at standstill and the output relays are enabled. The same is valid for operation with electronic controllers, if these produce a DC voltage e.g. during braking of a DC-brake.

9. Connection diagramm

9.1 with 3-phase motor

suitable up to SIL3, Performance Level e, Cat. 4

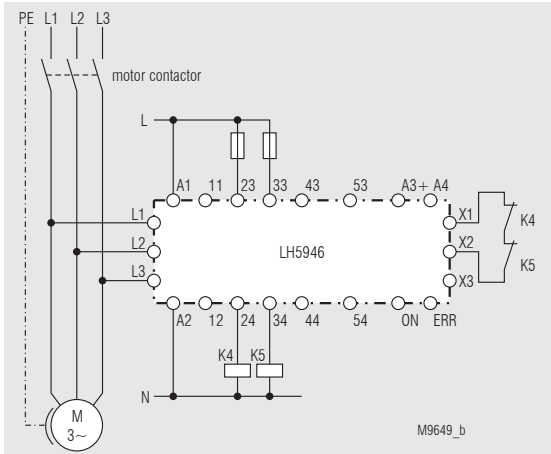

9.2 with single-phase motor

suitable up to SIL3, Performance Level e, Cat. 4

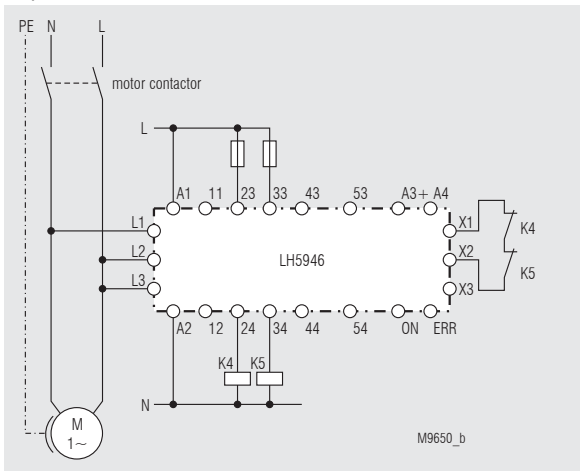

9.4 Typical connection combination with star delta timer, 2-channel connection of the measuring inputs

suitable up to SIL3, Performance Level e, Cat. 4

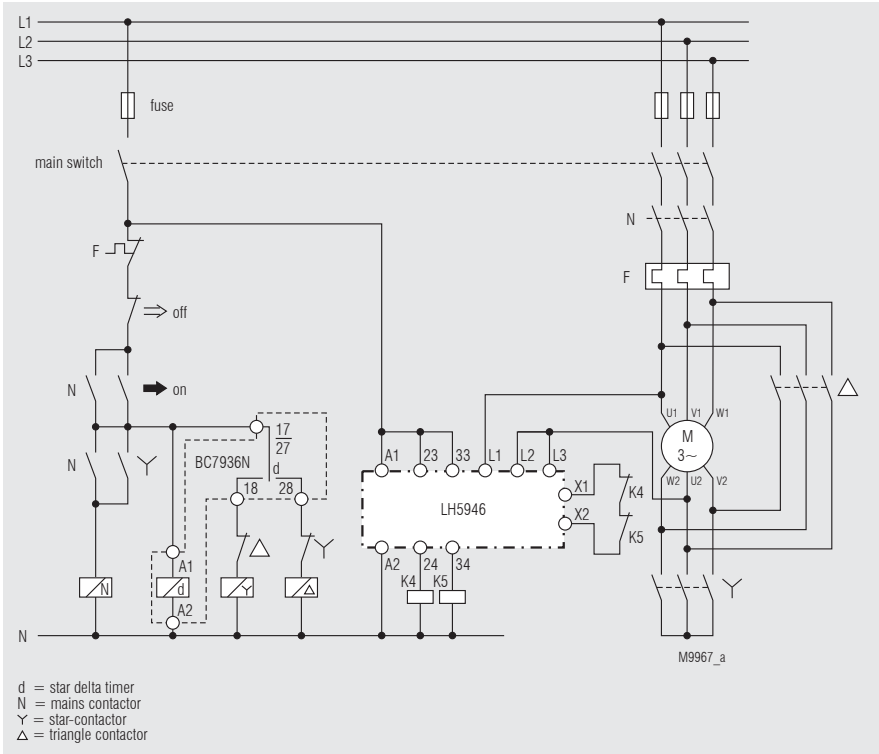

9.5 Typical connection combination with star delta timer, 3-channel connection of the measuring inputs

suitable up to SIL3, Performance Level e, Cat. 4

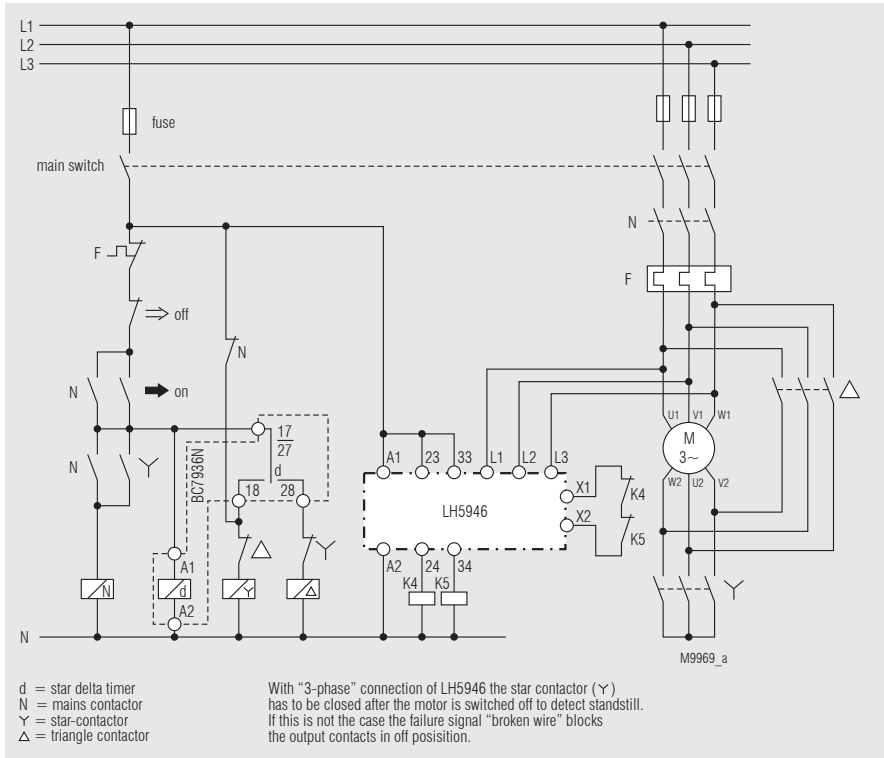



www.peter-electronic.com

