

Combined Motor Start and Braking Devices
VersiComb II Safe
Assembly- and Commissioning Instructions

Translation from original manual

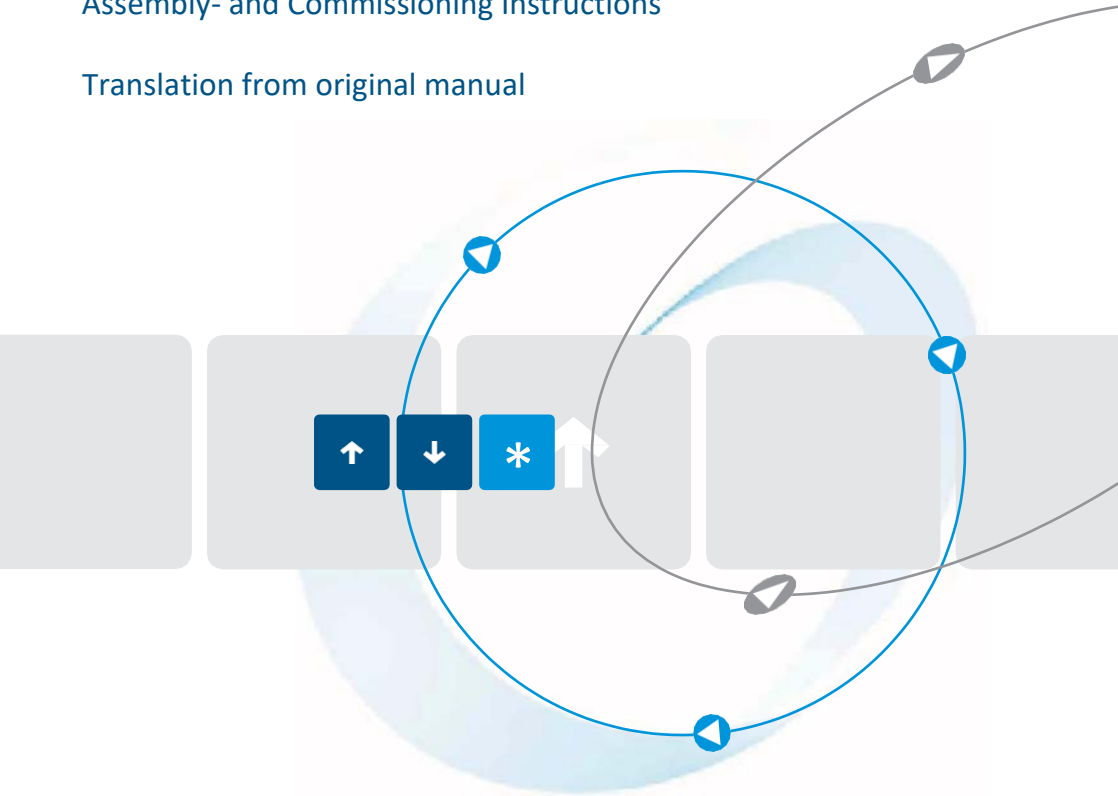

As per 08/24 1C300.10001

Table of Contents	Page
1. Safety information	5
1.1 Notes on safety	5
1.2 Warning note	6
2. Conformity	6
3. General description.....	7
4. Utilisation according to specification.....	8
4.1 Foreseeable misuse.....	8
5. EU Declaration of Conformity.....	9
6. Declaration related to functional safety.....	10
7. Block diagram	11
8. Operational start-up	12
8.1 Installation information	13
8.2 Connection.....	16
8.3 Parameter adjustments	17
8.4 LCD operator panel / menu language.....	18
8.4.1 Display / Operation	19
8.4.2 Programming mode	30
8.4.3 Description of the adjustable parameters.....	31
8.4.4 Fault mode	38
8.4.5 Operating sequence	40
8.5 System reset.....	42
9. Starting and stopping	42
9.1 Soft start	42
9.2 Braking	45
9.3 Safety time.....	45
10. Thermal overload protection.....	45
10.1 Motor temperature monitoring.....	45
10.1.1 Selection motor temperature sensor	45
10.1.2 Thermal motor image.....	46
10.2 Devices temperature monitoring.....	48
10.2.1 Thermal device image	48
10.2.2 Heatsink / device temperature.....	50
11. Extended, optional operating functions.....	51
11.1 External motor standstill monitor	51
11.2 Recording the rotational speed of tools	52
12. Operational signals	54
13. Faults.....	55

13.1	Centralised fault	55
13.2	Device fault	57
13.3	Reset fault.....	59
14.	CAN-BUS	59
15.	Technical data	60
15.1	General specifications (12-60A-Devices).....	60
15.2	General specifications (90-140A-Devices).....	62
15.4	Environmental conditions	64
15.5	Safety specifications	64
15.6	Safety figures	64
15.7	Dimensions	65
16.	Dimensioning rules	65
16.1	Dimensioning of fuses for device protection	65
16.2	Motor protection switch	67
17.	Installation guideline	67
17.1	Connection.....	67
17.2	Earthing	67
17.3	Cabling	68
18.	connection proposals	69
18.1	connection proposal: Standard wiring diagram	69
18.2	connection proposal: Reversing circuit with switch	70
19.	Timing diagram	71
19.1	Switch-on of the control voltage 24 V DC	71
19.2	Switch-on of the 24 V DC control voltage and the mains voltage	71
19.3	Start/Stop procedure	72
19.4	Switch-on of the voltages if motor rotates.....	72
19.5	Occurrence of an device fault.....	73
19.6	Occurrence of a Combined fault.....	73

You must read and understand this manual before installing, operating, or maintaining this device.

This start-up instruction was generated with the greatest care. Nevertheless the company PETER electronic GmbH & Co. KG assumes no liability for damages which result from possible included faults. We reserve the right to technical changes which serve for the improvement of the product.



Installation notice

Electro-technical specialist knowledge is required for installation and commissioning.



Disposal Instructions

Equipment containing electrical components may not be disposed of together with domestic waste. It must be collected separately as electrical and electronic waste according to local and currently valid legislation.

Symbols and abbreviations used

Note: Notes explain the advantages of certain adjustments and help you to obtain optimal benefit from the device.



Warning notes: Read and follow these carefully!

Warning notes should protect you against hazard or to help you to avoid damage to the device.



Attention! Electric shocks can be fatal!

If you see this symbol, then always check whether the device is voltage-free and secured against inadvertent switching on.

1. Safety information

1.1 Notes on safety

The device may only be used for applications specified in the accompanying installation and commissioning instructions. The notes in the associated documentation must be observed. The permissible ambient conditions must be observed.

Mount the device in a control cabinet with IP 54 or better. Otherwise, dust and moisture may impair its function



The devices are equipment used in industrial power installations. Improper removal of covers during operation can cause serious health damage, as these devices contain live parts with high voltages.

Installation, maintenance, adjustment, and operation must be carried out only by competent persons who are familiar with this technical documentation and the applicable regulations on occupational safety and accident prevention. Installation work may only be carried out in a de-energized state.

Note proper grounding of all drive components.

Before you put the device into operation, please read this start-up instruction carefully.

The user has to furthermore ensure that the devices and the relevant components are mounted and connected according to public, legal and technical specifications. The VDE Specifications VDE 0100, VDE 0110 (EN 60664), VDE 0160 (EN 50178), VDE 0113 (EN 60204, EN 61310) and VDE 0660 (EN 50274), as well as corresponding specifications of TUEV and Trades Social Insurance against Occupational Accidents, apply for Germany.

It must be ensured by the user that, after a failure of the device, in case of faulty operation, in case of failure of the control unit and so forth, the drive is brought into a secure operating state.

1.2 Warning note



- The safety functions of the VC II S (see point 3. General description) are only applicable in connection with further measures, e.g. protective door interlock
- In the case of an error it can not be excluded that the engine will start to turn. This must be observed especially when the safety door is open. This can be prevented if it is constructively ensured on the drive side that the motor does not start up with 2 mains phases (two-pole motor or heavy motor start).
- The unbraked run down of the motor to a standstill must not exceed 300s. Here the highest possible rotational speed and the largest possible centrifugal mass must be taken into account.
- The VC II S complies with the safety-relevant EMC Regulations (see 14.2 EMC information). In the event of interference levels greater than the limits unsafe operating conditions may occur.
- Even if the motor is stopped and the motor standstill message indicates a motor standstill, the device terminals 2T1, 4T2 and 6T3 as well as all connected cables and motor terminals are not galvanically isolated from the mains voltage.
For all work on the motor circuit and on the associated wiring, the VC II S must be disconnected from the mains voltage with a revision switch, motor protection switch or similar disconnecting elements.
- Strong electromagnetic fields can occur in the vicinity of plants/machines in which these devices are installed. It is possible to influence the operating behavior of active implants (e.g. pacemakers or defibrillators).

The PETER electronic company GmbH & Co. KG does not assume any responsibility for effects of the designated points.

2. Conformity

The devices described have been developed to take over safety-related functions as part of an overall system or machine. A complete safety-related system usually contains several components and concepts for safe shutdowns. It is the responsibility of the manufacturer of a system or machine to ensure its correct overall function. PETER is not able to guarantee all the properties of a complete system or machine that has not been designed by PETER.

The agreement of the construction of the user with the existing legal provisions is in the area of responsibility of the user.

The operational start-up is prohibited from for so long until the conformity of the finished product is stipulated with the Directives 2006/42/EG (Machinery Directive) and 2006/95/EG (Low-Voltage Directive).

The operation of the devices according to specification presupposes an electricity supply systems in accordance with DIN EN 50160 (IEC38).

3. General description

The devices of the type VersiComb II Safe (PL c) enable the soft start, as well as the abrasion-free slowing-down, of three-phase motors of the efficiency classes IE1 to IE3 (IE4 under preparation). An impact-free torque rise, as well as a current reduction in the start phase, are advantages with respect to direct starting or star-delta start-up. The II VC S - devices are used for drives with which a soft switch-on moment is required for the care of the drive components, and which must be slowed down reliably for safety and functional reasons.

With the employment of the VC II S, no additional motor contactor is required. We nevertheless recommend a mains/motor protection for reasons of electrical isolation. If the terminals of the start/stop control input are jumpered, the motor soft start starts. A device-internal monitoring identifies when the motor has reached its rated speed and signals the end of the start-up phase over a monitored, positively-driven relay contact. Simultaneously the power semiconductors are bridged by integrated contacts. In this way the power dissipation in normal operation is minimised.

If the start/stop contact is open, the braking phase begins. A controlled direct current is injected into the motor, which generates a standing field, and thus a braking torque. An integrated evaluator identifies the motor standstill. The braking current is then switched off and the shutdown is transferred externally over a monitored, positively-driven relay contact.

If no motor shutdown is identified within a stipulated monitoring time, the braking current is switched off and the motor shutdown is output only after a safety time of 300 sec. (unbraked rundown time with largest flywheel) over the secure, positively-driven shutdown signal contact. The user has to ensure that the unbraked rundown time of his drive (with largest flywheel) is not longer than 300 sec.

With application of the mains voltage, the device implements a test braking which checks the device functions. If the start/stop input is activated during test braking, the signal relay output "Centralised fault" opens and then the red LED flashes. After implemented test braking, the contact closes again. The device is capable of optimising the startup time and the braking time within 3 starts.

The optimal starting and braking time is assumed to be <10s.

So that the relevant specifications of DIN EN 12750:2013 (safety of wood processing machines) are met in the device, the functions:

- Prevention of an unexpected, fault-dependent start
- Monitored, controlled shutting down
- Secure control activation of the protection door interlocking
- Motor shutdown monitoring

structured in agreement with the requirements of Category 2, PL c from EN13849-1:2008, as well as SIL1 to DIN EN 61508.

The most varied faults are identified in VC II S. All faults which no longer enable a secure motor operation lead to a switch-on interlocking and are output simultaneously over the monitored, positively-driven relay contact "Equipment fault". Device faults can be reset only by a disconnection of the control voltage.

Non-safety-relevant faults are output over the indicator contact "Centralised fault". Centralised faults can be reset over the input "Fault acknowledgement".

Over a CAN interface with CAN-Open protocol, device parameters and signals can be exchanged with a higher-level control.

4. Utilisation according to specification

The devices of the VC II S series are soft-start, brake combinations. They are designed for use in machines to reduce the starting torque, to reduce the starting current peaks, and to decelerate flywheel masses on drives with three-phase asynchronous motors in efficiency classes IE1 to IE3.

Preferred areas of application

- Vibrator
- Wood processing machines
- Centrifuges
- Drives with large centrifugal masses
- Belt drives

4.1 Foreseeable misuse

The VC II S series devices must not be used for the following applications:

- For speed control of three-phase motors.
 - For the function of a holding brake (constant braking).
 - To start three-phase motors with a flywheel that exceeds a ramp-up time of 25 s.
 - For braking three-phase motors with a flywheel that exceeds a stop time of 25s.
 - For operation of three-phase motors with a flywheel mass that exceeds an unbraked ramp-down time of 300s.
 - For operation on a supply mains that is generated by a static transformer (frequency converter).
 - For gentle starting of three-phase transformers.
-

5. EU Declaration of Conformity

EU Declaration of Conformity

The manufacturer / marketing agency
(authorised agent of the manufacturer / marketing agency established in the community)

Name / Address: PETER electronic GmbH & Co. KG
Bruckäcker 9
92348 Berg

herewith declares that the following product (device, component, component part), in the implementation as supplied,

Product designation: Motor start-braking combination
Series / Type designation: VC II S ... - 12/ - 22/ - 37/ - 50/ - 60/ - 90/ - 110/ - 140
Article number: 2C3
Year of construction: 2016

corresponds to the determinations in accordance with EU Directive:

2014/30/EU over the electromagnetic compatibility
2011/65/EU for the limitation of the utilisation of certain hazardous materials in electrical and electronic devices
2006/42/EC machinery directive

The following harmonised standards were employed:

DIN EN 60947-1:2022-03 Low-voltage switching devices
General stipulations
DIN EN 60947-4-2:2024-04 Low-voltage switching devices
Contactors and motor starters - semi-conductor motor control units and starters for AC voltages
DIN EN ISO 13849-1:2016-06 Security of machines
DIN EN ISO 13849-1:2023-12 Security of machines
DIN EN IEC 62061:2023-02 Security of machines

The conformity of the VC II S device series with the standards and guidelines listed above has been established:

Notified body: TÜV Rheinland Industrie Service GmbH
Am Grauen Stein
51105 Köln / Germany
Notified Body Nr. 0035

EC type examination certificate: 01/205/5706.01/24

This product has been designed as a Class A device. Use in Class B environments (such as residential areas) may cause radio interference. In case of malfunctions, appropriate measures are to be taken.

This EC Declaration of Conformity loses its validity if the product is altered or changed without approval. The undersigned bears sole responsibility for the presentation of this declaration.

Berg, 20.02.2024
(Location, Date)

Dr. Thomas Stiller, Managing Director
(Undersigned and function of the undersigned)

(Signature)

6. Declaration related to functional safety

EC Type-Examination Certificate





Product Safety
Functional Safety

www.tuv.com
ID: 060000000

Reg.-No.: 01/205/5706.00/19

Product tested	Safety Functions - Prevention of an unexpected, fault-dependent starting - Monitored, controlled stop to standstill - Secure control of a safety gate - Motor standstill monitoring within the VC II S Engine start / brake system	Certificate holder	Peter electronic GmbH & Co. KG Bruckäcker 9 92348 Berg Germany
Type designation	VC II S NNN-SS V X (VersiComb II Safe) *NNN: 480, 575, 690 (Supply Voltage [V]) *SS: 12, 22, 37, 50, 60 (Nominal Current [A]) * V: non safety relevant * X: non safety relevant		
Codes and standards	EN 60947-4-2:2012 ISO 13849-1:2015	IEC 62061:2015 EN 61508 Parts 1-7:2010	
Intended application	The Safety Functions of the Engine start / brake system VersiComb II Safe comply with the requirements of the relevant standards (Cat. 2 / PL c acc. to EN ISO 13849-1, SIL CL 1 acc. to EN 62061 / IEC 61508) and can be used in applications up to PL c and SIL 1. The usage of further protective measures, e.g. protective door in combination with the standstill output (X143, X144), is mandatory required. The usage of a motor contactor is recommended, but not mandatory required.		
Specific requirements	The Assembly- and Commissioning Instructions shall be considered.		
	It is confirmed, that the product under test complies with the requirements for machines defined in Annex I of the EC Directive 2006/42/EC.		
	Valid until 2024-03-21		
	The issue of this certificate is based upon an examination, whose results are documented in Report No. 968/FSP 1808.00/19 dated 2019-03-21. This certificate is valid only for products which are identical with the product tested.		
Köln, 2019-03-21	 Notified Body for Machinery, NB 0035		 Dipl.-Ing. Eberhard Frejno
www.fs-products.com www.tuv.com		 TÜVRheinland® Genau. Richtig.	

7. Block diagram

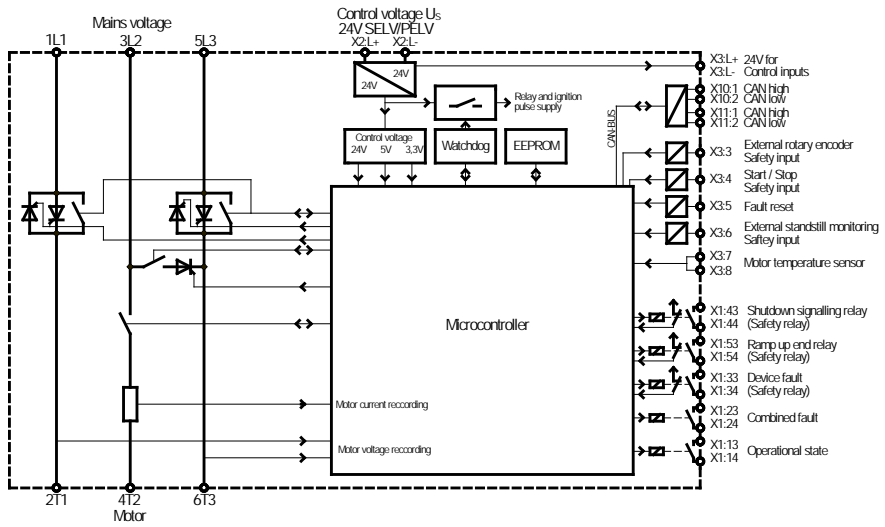

8. Operational start-up



Installation notice

Installation and commissioning requires "electrical expertise".

Commissioning takes place in 4 steps:

Step 1 Assembly	see Chapter 8.1
Step 2 Connection	see Chapter 8.2
Step 3 Parameter settings	see Chapter 8.3
Step 4 Test of the safety functions	

Commissioning must be completed with a test for the operation of the safety functions!

Make sure that no one is in the safe area of the machine or near the drive motors.

- The motor must not start under any circumstances when the starting contact is open, if the mains voltage is switched on, or the 24V control voltage is switched off when mains voltage is applied
- If the motor is switched off through the starting contact, the motor must reach standstill within 9 seconds at the latest after the third braking.
- The MS output contact X1: 43 - X1: 44 must be open from the start of the soft start to the motor standstill after braking (rotating motor). If a protective door is connected to this contact, it must be closed and locked when the motor is rotating.
- If the motor spins out if the mains voltage is switched off after reaching the rated speed, the enclosed safety door must remain locked for 300 s with the 24 V control voltage present.
- The coasting motor with its maximum flywheel mass must come to a standstill within 300s from the rated speed.



Warning note

Consider the maximum admissible starting and braking currents (see Technical Data).

8.1 Installation information



Attention! Electric shocks can be fatal!

The following conditions are to be adhered to for a proper operation of the VersiComb II:

1. The VC II S is to be used under overvoltage conditions of Category III.
 2. The device may be used only in an environment with degree of pollution 2 or better, in accordance with DIN EN 60644-1/IEC664.
 3. The device is to be installed in a housing (protection type at least IP54). Attention is to be paid that the waste heat generated by the soft startup-braking combination can be removed via the housing.
 4. The device must be operated free from contamination by water, oil, carbon, dust etc.
 5. With the connection of the devices of construction size 1 (12A, 22A, 37A), it is to be noted that the network and motor lines are stripped of insulation for 18 mm and, in case of construction size 2 (50A and 60A), stripped of insulation for 15 mm. If lines are stripped of insulation too short, or with too short end sleeves and are used for the connection, this leads to a high contact resistance and to ultimate destruction.
 6. Employment in North America, UL and CSA permit
Utilisation en Amérique du Nord, certifié UL et CSA.
 - 6.1 Wiring diagram: see Table 17, "Anschlussvorschlag," on page 33
Schéma de câblage : voir Tableau 17, " Schéma de raccordement général ", à la page 33
 - 6.2 The terminal tightening torque of lbs-in (Nm): see Table 14.1, "Allgemeine Angaben," on page 25
Couple de serrage des bornes en lbs-in (Nm) : voir Tableau 14.1, " Caractéris- tiques techniques ", à la page 25
 - 6.3 To be used in a Pollution Degree 2 environment only.
À utiliser uniquement dans un environnement de degré de pollution 2.
-

- 6.4 Suitable for use on a circuit capable of delivering not more than 5000 rms symmetrical amperes, 600 Volts Maximum and when protected by fuse or circuit breaker tabulated in the table below:

Peut être utilisé sur un circuit capable de fournir un courant RMS symétrique de 5 kA maximum, 600 volts maximum et si protégé par fusible ou disjoncteur tabulé dans le tableau ci-dessous:

Device Model	Branch Circuit Protection Cat. No)	Max. Branch Circuit Protection Rating
VC II S 575-12 VC II S 480-12	Class RK5 Fuses	25A
VC II S 575-12 VC II S 480-12	Circuit breaker PKE 16-65A	16A
VC II S 575-12 VC II S 480-12	Circuit breaker 3RV2011_16-22A	16A
VC II S 575-12 VC II S 480-12	Circuit breaker PKE 3RV2021_18-25A	20A
VC II S 575-22 VC II S 480-22	Class RK5 Fuses	40A
VC II S 575-22 VC II S 480-22	Circuit breaker PKE 16-65A	65A
VC II S 575-22 VC II S 480-22	Circuit breaker 3RV2031_22-32A	32A
VC II S 575-37 VC II S 480-37	Class RK5 Fuses	60A
VC II S 575-37 VC II S 480-37	Circuit breaker PKE 16-65A	65A
VC II S 575-37 VC II S 480-37	Circuit breaker 3RV2031_35-45A	45A
VC II S 575-50 VC II S 480-50	Class RK5 Fuses	80A
VC II S 575-50 VC II S 480-50	Circuit breaker PKE 16-65A	65A
VC II S 575-50 VC II S 480-50	Circuit breaker 3RV1041_42-52A	45A
VC II S 575-60 VC II S 480-60	Class RK5 Fuses	100A
VC II S 575-60 VC II S 480-60	Circuit breaker PKE 16-65A	65A
VC II S 575-60 VC II S 480-60	Circuit breaker 3RV2031_62-73A	73A

- 6.5 Surrounding temperature max. 45°C

Température ambiante 45 °C max.

- 6.6 Use copper conductors 60/75°C, or 75°C only

Utiliser des conducteurs en cuivre avec une résistance thermique de 60/75°C, ou 75 °C uniquement.

Set the device vertically on a vertical installation surface. The motor terminals are to be mounted below. The installation is implemented by screwed connection of the four fastening plates. The devices can be set in a row near each other without separation distance. If the devices are arranged above each other, a separation distance of 100 mm must be kept between the heatsinks. No additional large heat sources may be arranged below the devices, such as e.g. devices with high power dissipation, heat resistors or similar.

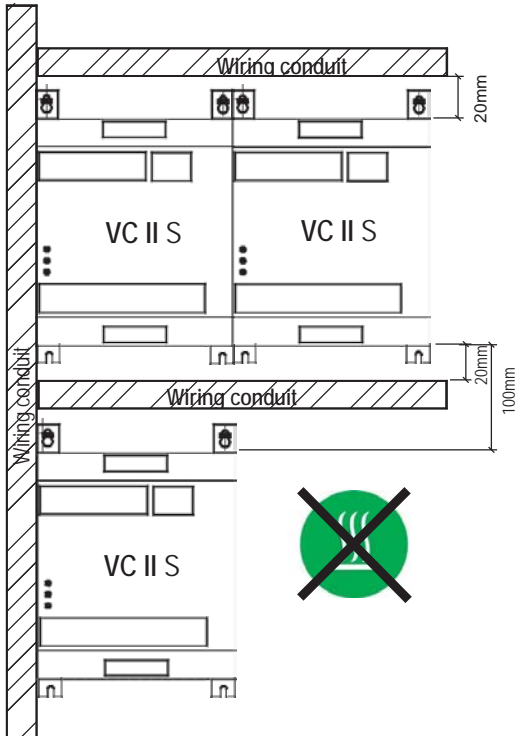

Warning note

For the avoidance of heat backups, a separation distance of at least 20 mm is to be kept between wiring system conduit and device.

8.2 Connection

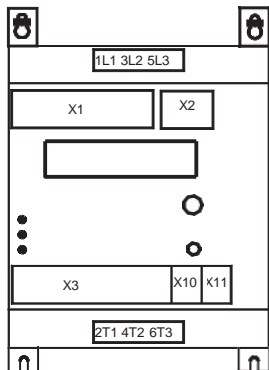

Power module (see also terminal diagram)

Terminal 1 L1:	Mains voltage L1
Terminal 3L2:	Mains voltage L2
Terminal 5L3:	Mains voltage L3
Grounding connection ⊕	PE
Terminal 2T1:	Motor connection T1
Terminal 4T2:	Motor connection T2
Terminal 6T3:	Motor connection T3



Attention!

When connecting the mains and motor cables for size 1, strip the insulation at least 18mm, for size 2 the insulation at least 15 mm and for size 3/4 25mm!
Tightening torque for size 2: 3 ... 3,5 Nm (26,3 ... 31 lbs-in)



Control part

Control outputs - terminal block X1

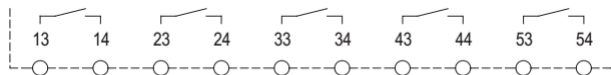

Operating state Combined fault Device fault Motor standstill Ramping up

With the output contacts, it involves relay contacts 250VAC/4A; 30VDC/4A

Control voltage U_s - terminal block X2

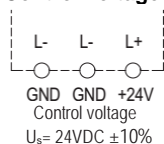

An external control voltage U_s of 24VDC $\pm 10\%$ is connected to the terminals L+, L-. The voltage source must be able to deliver a current of at least 1A. If there are several devices, a correspondingly higher current is required.

Control inputs - terminal block X3

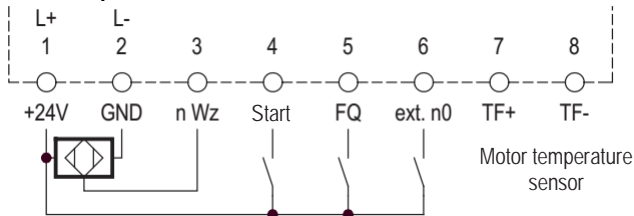

The input impedance of the control inputs is 5 kOhm. Switch contacts, which can securely switch the lower control currents (4.8mA), must be used for the control activation!

The terminal X3:1 (L+) is connected internally with the terminal X2:L+.

The terminal X3:2 (L-) is connected internally with the terminal X2:L-.

The input terminals X3:3 to X3:6 are control-activated with the L+ potential.

X3:3 -n tool . recording of the tool rotational speed

X3:4 -Start- Start/Stop input. 24 V = motor is started, 0 = motor is stopped.

X3:5 -FQ- reset of the combined fault 24 V - reset of fault.

X3:6 -ext. n0-external standstill monitoring. 24 V - motor standstill identified.

The motor temperature monitoring is connected to the terminals X3:7 and X3:8 (TF+ and TF-).

- Thermo-switch (open = over-temperature)
- Motor PTC
- Motor KTY84 (case of utilisation of a KTY, the motor temperature can be scanned over CAN bus or LCD operator panel).
- Motor PT1000 (case of utilisation of a PT1000, the motor temperature can be scanned over CAN bus or LCD operator panel).

CAN sockets X10, X11 (RJ45)

1 = CAN H

2 = CAN H

3 = GND



Attention! Electric shocks can be fatal!

Even if the motor stops, it is **not** isolated galvanically from the network.

8.3 Parameter adjustments

The devices are delivered with a default parameter set.

Motors with a power rating which is in the range of the device power rating are adjusted to an optimal starting and braking time after a maximum of 3 starting and 3 braking operations.

The default value is 9s for the starting time and 8s for the braking time.

If a parameter adaptation is necessary, this can be carried out over CAN bus or the LC display panel with rotation selection key, according to the parameter list.

8.4 LCD operator panel / menu language

The menu language can be changed through pressing the button and holding it pressed. After approx. 5 sec, the display changes into the Selection mode and the required language can be adjusted with the rotating encoder. The adjusted language is confirmed with the button and the display changes into the selected language.

The devices are equipped with a two-line LC display to display the states and programming modes, as well as with a rotating encoder pushbutton function to control and data input.

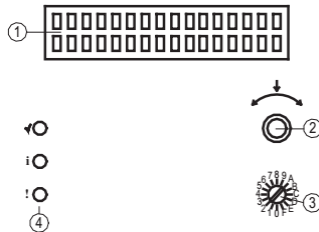

1	two-line display for operating states, parameters and programming
2	<p>Rotation encoder with pushbutton function for navigation in the menus and data input</p> <p>Scrolling in the menus and value input</p> <p>Pushbutton actuation:</p> <p>1. short press -</p> <p>A.) Main menu: Call-up of a menu, sub-menu, parameter group or parameter level</p> <p>B.) Parameter level: Leaving the parameter level and skipping back into the parameter groups</p> <p>C.) Programming mode: Call-up of a program parameter group and program parameter level. Confirm change mode or value selection.</p> <p>2. long press (>1s) -</p> <p>A.) Status menu: Skipping back into the main menu and display of operating state</p> <p>B.) Programming mode: Saving the parameter value or leaving the change mode or skipping back into the higher-level menu.</p>
3	CAN - bus address selection switch
4	<p>3 LED's for the status display</p> <p>LED green - device ready to operate</p> <p>i LED yellow - off</p> <p>Flashes with increasing frequency - Operating state "Standby"</p> <p>Double flashing - Operating state "Soft start"</p> <p>Continuous lighting - Operating state "Braking"</p> <p>! LED red - Continuous lighting - Operating state "Bypass"</p> <p>Flashes - Device fault</p> <p>- Combined fault</p>

The LCD display has a back lighting with a standard lighting duration of 15 sec. The lighting duration can be changed under the system parameters in the programming mode. If the rotating encoder or button becomes activated, the back lighting switches on.

8.4.1 Display / Operation

8.4.1.1 Display

In the operator panel, a wide range of operating modes of the soft start / braking combination are displayed.

After the switching on of the control voltage, as well as the mains power supply, the device is initialised and a test braking then carried out. If the test braking has been completed successfully, the device changes into the operating state "Standby" and the device status appears in the display.

Standby	Remote	-- Operating mode: control via control terminals
Standstill	OK	-- Motor standstill identified (status indicator line)



In the status indicator line, different operating values can optionally be displayed. The selection is implemented with the parameter "Status display main menu" in the programming mode. The following options are available for selection:



Standstill OK

- 1 Motor current
- 2 Motor voltage
- 3 Mains voltage
- 4 Device operating status
- 5 Device temperature
- 6 Thermal device image
- 7 Heat sink temperature
- 8 Motor temperature

8.4.1.2 Operation





The device is operated with the rotating encoder placed on the front side with pushbutton function.

-  Rotating encoder right / left
-  Press rotating encoder shortly / for a long duration

As a result of right-hand or left-hand turning of the rotating encoder () , scrolling in the main menu takes place. After selection of a menu, the rotating encoder is pressed shortly () , a branch-out into the corresponding sub-menu occurs.

Menu selection and change of the parameter values are controlled over the rotating encoder. With actuation of the button, a skip is made into the next menu level or a selected level is left.

If no actuation is implemented for 20 sec in the status Parameter mode or 30 sec in the Programming mode, the display returns to the standby operating state. On leaving the Programming mode, the values are saved on request only.

With the rotating encoder () , scrolling can be now be implemented through the submenus. If a submenu is selected, by short pressing of the button () a skip is made into the parameter group. By rotating the rotating encoder () , scrolling can be implemented between the parameter groups. If a group has been selected and the button pressed shortly () , a change is made into the parameter level. Here, a selection can be made () between the individual parameters of a group by turning the rotating encoder. In the display, the corresponding

parameter value is displayed. The parameter values can be changed here in the Programming mode.

A return to the group level is achieved by short pressing of the button  alternately or through long pressing of the button in the Standby mode.

In the Standby mode, in bypass operation or during the rundown of the safety time period, a change can be made to the status parameter menu or into the Programming mode. As a result of long pressing  during bypass operation or during the safety time period, a change is made into the main menu. The menu groups Status parameter and Programming mode can now be selected between.



A. Status parameter:

All device parameters, subdivided into groups, are displayed (see Table 8.4.1.1 on Page 17):

- A.1 Device data
- A.2 Motor data
- A.3 Start parameter
- A.4 Brake parameter
- A.5 System parameter
- A.6 Operating data
- A.7 Status messages
 - A.7.1 Device status
 - A.7.2 Combined fault
 - A.7.3 Devices fault

B. Programming mode:

In the programming menu all adjustable parameters can be displayed and changed (see Chapter 8.4.3 on Page 27) with which the VersiComb is controlled.

In order to open the programming menu, a password must first be entered () and confirmed (). The programming menu is subdivided into the following groups:

- B.1 Motor data
- B.2 Start parameter
- B.3 Brake parameter
- B.4 System parameter
- B.5 CAN parameter
- B.6 Expert mode
 - B.6.1 Start parameter
 - B.6.2 Brake parameter
 - B.6.3 System parameter
- B.7 Programming Mode Quit

8.4.1.1 Description of the display texts in the status parameter menu

Display	Description	CAN param.
A.1 Device data		
Rated Device-Voltage V	Device voltage	5001
Rated Device - Current A	Device rated current	5001
Warning temperat Device °C	Device warning temperature	4026
CAN-Bus Baudrate kB	speed of the CAN bus (trasfer rate)	5006
CANopen Node ID	current address setting CANopen Node ID	5006
CANopen Node ID Base	current CANopen Node ID basis	5006
CANopen Node ID Offset	current CANopen Node ID offset	5006
CANopen Heartbeat	current CANopen heartbeat	1017
A.2 Motor data		
Rated Motor-Current A	Motor rated current according to nameplate resp. device rated current (I_{Mtot}). In case of factory settings or factory reset, the parameter motor rated current corresponds to the device rated current. This parameter refers to the parameter reference rated current 4014(System Parameters)	4032
Rated Motor-Voltage V	current motor voltage.	5502
Set Point Motor-Current A	Setpoint value of the start current with current control start mode.	5008

Display	Description	CAN param.
A.3 Start parameter		
Motor StartMode 0=U 1=IO 2=lwO	Selection of the start mode as the motor starts. Soft start through voltage ramp or current control. 0 = U -> voltage ramp 1 = IO -> current control with start-up period optimisation 2 = lwO -> current control without start-up period optimisation	4002
Starting Current StrtMode1/2 A	Setpoint value of the start current with start-up mode 1 or 2, see selection parameter StartMode 4002.	3003
Min. Start Curr StrtMode1/2 A	Minimum possible starting current with start-up mode 1 or 2, see selection parameter StartMode 4002. The starting current is not controlled below this minimum value.	4059
Current LowLimit Starting %	During start-up and after the expiration of the acquisition time and the motor current is dropping below the limit, a device fault is triggered.	4508
Motor Starting Time s	- StartMode 0 "Voltage ramp" - the value correspond to start-up period - StartMode 1 "Current control with start-up period optimisation" - the value is the setpoint for start-up period optimisation. See parameter selection StartMode 4002	3001
Max. Start Time StrtMod=1/2 s	Maximum permissible start-up period at StartMode 1 and 2. After exceeding, a combined fault is triggered.	4034
Starting Voltage U-Mains x %	Starting voltage in % of the mains voltage only if StartMode 0 "voltage ramp" is selected, see parameter 4002.	3002
Starting Self- Tuning	After this number of starts, the actual start-up period value must be shorter than the adjusted start-up period in parameter 3001. Only if StartMode 1 is selected, see parameter 4002. In case of exceeding, a combined fault is triggered.	4001
Boost Start 0=Off 1=On	Start with boost-pulse (kickstart). 0 = Off = Boost inactive 1 = On = Boost active	3004
Boost Start Duration ms	Duration of the boost pulse.	4011
Boost Level if Boost = On %	Boost level during boost pulse at Boost Start = On. - At StartMode 0 " Voltage ramp": Boost level in % of the mains voltage. - At StartMode 1 or 2 " Current control...": Boost level in % of the 6-times rated motor current with reference to parameter 4032.	4010
Boost Current if Boost=On A	Boost motor current at StartMode 1 or 2 " Current control...": Boost current = Boost level * 6-times rated motor current with reference to parameter 4032.	4010
Current Increase Temperature	In case of motor temperatures less than 40°C, an start current increase is implemented to at least 4x the motor current. Only in case of KTY or PT1000 motor protection measurement and current regulation. 0 = motor-temperature current increase Off 1 = motor-temperature current increase On	4079
I-Amplification Start	I-content start current regulation only in case of current control.	4006
P-Amplification Start	P-content start current regulation only in case of current control.	4007
Sampling Time Softstart ms	Sampling time of the current actual values	4081
Current Lower Limit Strt %	In start operation, an device fault is caused after expiry of the measuring time and undershooting the current lower limit.	4508
Monitor. Current Low Limit ms	Measuring time of the current lower limit in operation after which an device fault is triggered.	4509
Current High Limit Strt A	In start operation, an device fault is triggered after expiry of the measuring time and exceeding the current upper limit.	4510
Monitor. Current Hi Limit ms	Measuring time of the current upper limit in start operation after which an device fault is triggered.	4511
Restarts Unbal. ZeroCrossing	Restart attempts at imbalance of the zero-crossing	4526

Display	Description	CAN param.
A.4 Brake parameter		
BrakeMode 0=SO 1=SwO 2=t 3=PW	Selection of the braking mode as the motor is stops. 0 = SO -> Standstill-dependent braking with braking time optimisation 1 = SwO -> Standstill-dependent braking without braking time optimisation 2 = t -> Time-dependent braking 3 = PA -> Braking with fixed phase angle, see parameter 4801	4003
Motor Braking Time ms	- At BrakeMode 0 "Standstill-dependent braking with braking time optimisation" - the value is the setpoint for braking time optimisation. - At BrakeMode 2 "Time-dependent braking" - the value correspond to the braking time. See Parameter BrakeMode 4003.	3006
Set Point Brake Current A	The setpoint value of the braking current at BrakeMode 0, 1 or 2, see parameter selection 4003.	3005
Minimal Braking Current A	Minimum possible braking current at BrakeMode 0, see selection parameter 4003. The braking current is not controlled below this minimum value. Thus a deceleration of the motor is ensured.	4060
Monitoring Time Int. Brake ms	Monitoring of the braking time with internal standstill monitoring unit. The standstill must be dedected within this time. Only in case of BrakeMode 0 or 1, see parameter selection 4003.	4005
Max Second Brake Time ms	Post-braking time after motor standstill is dedected only with braking type 0 or 1, see parameter selection 4003.	4013
Selection Brake Termination	Activation or deactivation of the braking interruption, in order to perform a new motor start during a braking period, or to end the braking sequence completely before a new start is performed. 0 = No start during braking possible: Brake period will be finished before a new start is performed. 1 = Start during braking possible: Braking is interrupted, new start is possible immediately.	4030
Comb.Fault 3x No Standstill	Device fault triggered if no standstill identified 3x. 0 = inactive 1 = active	4021
Ext. Standstill Monitor	Standstill recognition with external standstill monitoring unit. 0 = External standstill monitoring unit inactive 1 = External standstill monitoring unit active	4004
Monitoring Time Ext.brake ms	Monitoring of the braking time with external standstill monitoring unit. The standstill must be identified within this time. Effective only in case of external standstill monitoring unit CAN Parameter 4004.	4015
Ext. Standstill Signal ms	Monitoring of the external standstill signal after disconnection of the braking current. Effective only in case of external standstill monitoring unit CAN Parameter 4004.	4031
Test Braking Delay ms	In case of several devices in a system, the test braking is triggered with a delay time. Delay time = Deceleration test braking x (switch position on the CAN address selection switch - 1) 0 = 0;	4080
Debounce Time Brake Relay ms	Duration of the bounce time of the braking relay. Close time period between braking relays and control activation of the braking current.	4020
I-Amplification Brake	I-content braking current regulation. Only in case of current control	4008
P-Amplification Brake	P-content braking current regulation. Only in case of current control	4009
Current Low Lim. Brake %	In braking operation, an device fault is caused after the measuring time and undershooting the current lower limit.	4516
Monitor. Current Low Limit ms	Measuring time of the current lower limit in braking operation after which an device fault is triggered.	4517
Current Hi Limit Brake A	In braking operation an device fault is triggered after expiry of the measuring time and exceeding the current upper limit.	4518

Display	Description	CAN param.
Monitor. Current Hi Limit ms	Measuring time of the current upper limit in braking operation after which an device fault is triggered.	4519
Mode Delay Time Brake	With this parameter, the mode of delay time (VZA) between motor release and control activation of the braking current is selected. 0 = Delay self-optimising 1 = Fixed delay time 2 = Delay time motor voltage-dependent	4017
Delay Time Brake ms	Delay between motor release and activation of the braking current at Mode Delay time 1 "fixed delay", see parameter 4017.	4018
Threshold Motor Voltage mV	Limit value of the motor voltage at Mode Delay time 2 "motor voltage-dependent", see parameter 4017.	4019
Detect. Standst. Delta t ms	Time (dt) of the current rise in case motor standstill detected by braking current form. When BrakeMode 0 or 1 is selected"Standstill-dependent braking ...", see parameter BrakeMode 4003.	4027
Detect. Standst. Delta I mA	Level (di) of the current rise in case motor standstill detected by braking current form. When BrakeMode 0 or 1 is selected"Standstill-dependent braking ...", see parameter BrakeMode 4003.	4028
Standstill Incr. Delta-t ms	Time period (dt) of the voltage rise with standstill recognition through remanence voltage.	4038
Standstill Incr. Delta-U mV	Level (du) of the voltage rise with standstill recognition through remanence voltage.	4039
Standstill OV Delta t ms	Time period (dt) of the 0-line undershooting with standstill recognition through remanence voltage.	4040
U-Remanence Cons Delta t ms	Time (dt) in which the remanence voltage must remain constant after motor standstill.	4041
U-Remanence Cons Window mV	Threshold value (u) minimum voltage in which the standstill identification works through remanence voltage.	4042
Toler. Remanence Voltage mV	Permissible voltage tolerance of the standstill recognition through remanence voltage.	4043
U-Rem Values Out Of Tolerance	Number of values which may not be in the permissible tolerance of the standstill recognition through remanence voltage. *	4075
Threshold Motor Standst. mV	Threshold value for the identification of the voltage standstill recognition. A change affects the identification of the motor standstill. This parameter may be changed only in discussion with PE. *	4069
Currentless Time Stdstill ms	Tolerance t for the identification of the currentless standstill. *	4070
Currentless Volt Stdstill mV	Tolerance U for the identification of the currentless standstill. *	4071
Stdstill Delta I Const. t ms	delta t for the identification of the current standstill in case of still rotating motor. *	4072
Stdstill Delta I Const. I	delta i for the identification of the current standstill with motor still rotating. *	4073
Threshold Motor Standst. mV	Threshold value for the identification of the voltage standstill with already motor standstill. *	4074
Sensitivity Curr Standstill	Sensitivity current standstill.*	4522
Remanence Volt. Standst. OV	Assessment remanence voltage standstill On/Off.*	4524
Braking Time level 1	Braking Time level 1	4082
Braking Time level 2	Braking Time level 2	4083
Braking Time level 3	Braking Time level 3	4084
Braking factor level 2	Braking factor level 2	4085
Braking factor level 3	Braking factor level 3	4086
Braking factor level 4	Braking factor level 4	4087
Phase Angle Brake		4801

Display	Description	CAN param.
A.5 System parameter		
ReferenceCurrent 0=M/1=D	Stipulates the reference to which the maximum start current or braking current refers. The start and braking current is calculated from the rated current. 0 = Motor -> Calculations refer to the motor rated current (default) 1 = Device -> Calculations refer to the device rated current	4014
Rated Operating Current A	Rated current that applies for the calculation of the start and braking current.	
Warning Temperat Device °C	If the device temperature reaches the adjusted value, a warning is issued. (default 70°)	4026
Temperat. Sensor Motor	Type of the motor temperature sensor (PTC/KTY84/Switch) or calculation of the thermal motor image. 0 = PTC 1 = KTY84 2 = switch 3 = PT1000 4 = thermal motor image (default)	4012
Motor Warning Temperature °C	If the motor temperature reaches the adjusted value, a warning is issued. Only active with KTY and PT1000 and motor protection	4023
Trip Temperature Motor °C	If the motor temperature reaches the adjusted value, a Combined fault issued. Only active with KTY and PT1000 and motor protection (default 155°)	4022
Re-Start Temper. Motor °C	If the motor temperature falls below the re-start temperature, the "Motor over-temperature combined fault" can then be reset. Only active with KTY and PT1000 and motor protection default 130°)	4024
Trip Class Start Braking	Release class for the calculation of the thermal motor protection for start-up and braking	3011
Trip Class StdbY Bypass	Trip class for the calculation of the thermal motor protection in standby and bypass operation.	3012
Cooling Down Time Motor s	Cool-down time of the motor in standby and bypass operation	3013
Deactiv. Motor Protection	Temperature monitoring of the motor is deactivated. The adjustment in CAN Parameter 4012 is ineffective with that. 0 = Motor protection active (default) 1 = Motor protection inactive	4033
Ext. Tool Speed Sensor	Activation of the external recording of the tool speed. 0 = Tool speed not recorded (default setting) 1 = Tool speed recorded	4035
Minimum External ToolSpeed	If the tool speed falls below the minimum tool speed, a combined fault is triggered.	4078
Monitoring Time ToolSpeed ms	Measuring time in which no pulse of the tool pulse generator should be recorded. Standstill identification.	4016
Ext. Tool Speed Tolerance %	If the tool speed decreases in bypass status and falls below the tool speed tolerance, a combined fault is triggered. (Belt break identification)	4076
Options Operatin State Relay	Assignments of the operating states which are displayed on the B2 signal relay. (default 464, binary coded: 111010000) 0 = Status is not displayed 1 = status is displayed	4077
Options Combined Fault Relay	The assignment of the combined faults which are displayed with the S5 signal relay. (Default setting 2047, binary coded:1111111111) 0 = fault is not displayed 1 = fault is displayed	4029
Mains Switch-Off Voltage V	Minimum mains voltage level in the 3 phases, which is identified as a switch-off threshold of the mains voltage. After the expiry of the network measuring time disconnection, Parameter 4501, a combined fault is triggered.	4507
Monitoring Mains Switch-Off ms	Measuring time of the network disconnection up to the activation of a combined fault.	4501

Display	Description	CAN param.
U-Mains Low Trip Value V	Lower tolerance limit of the mains voltage. After the expiration of the acquisition time a device fault is triggered.	4500
Limit Phase Sym. Standby %	Phase symmetry threshold in standby operation. If the limit value is exceeded and after the expiration of the acquisition time "Monitor. Pha-Sym Mains low", see parameter 4506, a device fault is triggered.	4502
Limit Phase Sym. Starting %	Phase symmetry threshold in start-up operation. If the limit value is exceeded and after the expiration of the acquisition time "Monitor. Pha-Sym Mains low", see parameter 4506, a device fault is triggered.	4503
Limit Phase Sym. Bypass %	Phase symmetry threshold in bypass operation. If the limit value is exceeded and after the expiration of the acquisition time "Monitor. Pha-Sym Mains low", see parameter 4506, a device fault is triggered.	4504
Limit Phase Sym. Braking %	Phase symmetry threshold in braking operation. If the limit value is exceeded and after the expiration of the acquisition time "Monitor. Pha-Sym Mains low", see parameter 4506, a device fault is triggered.	4505
Monitor.MainsLow Ph.-Symet ms	Monitoring time for the lower tolerance limit of the mains voltage and phase symmetry monitoring after which an device fault is triggered.	4506
Current Low Lim. Bypass %	In bypass operation, an device fault is caused after undershooting the monitoring time and current lower limit.	4512
Monitor. Current Low Limit ms	Monitoring time of the current lower limit in the handling mode after which an device fault is triggered.	4513
Current Hi Limit Bypass %	In bypass operation, an device fault is caused after overshooting the monitoring time and current upper limit.	4514
Monitor. Current Hi Limit ms	Monitoring time of the current upper limit in the handling mode after which an device fault is triggered.	4515
Time Kon.Thermal Image Bypass %	Calculation of the evaluation time (% of the fixed time constant) for the device temperature image in bypass operation.	4520
Curr.Kon.Thermal Image Bypass %	Calculation of the evaluation current (% of the current constants) for the bypass operation device temperature image.	4521
Light Period LC-Display s	Lighting period of the LCD background lighting. (default 30s)	3007
Status Display Main menu	Display value in the status display line in the main menu. The current values of the selected parameter are displayed.	3014
Device Type	Device type	5017
Hardware version	Hardware version	5018
Software version	Software version	5019

Display	Description	CAN param.
A.6 Operating data		
Actual Starts Total	Actual sum of the implemented starts	5015
Act. Start time Total s	Actual sum of the accumulated start-up times	5015
Act. Brake Time Total s	Actual sum of the accumulated braking times	5015
Act. Bypass Time Total s	Actual sum of the accumulated time in bypass operation.	5015
Act.Standby Time Total s	Actual sum of the accumulated time in standby operation.	5015
Act.Operat. Time Total s	Actual sum of the accumulated operating time	5015
Motor Current Act. value A	Actual motor current.	5008
Max Mot. Current Act. value A	Peak value of the motor current.	5008
Actual Motor Voltage V	Currently measured motor temperature	5015
Max. Motor Temp. X Y	Actual motor temperature According to selected temperature sensor X, the display value corresponds to YY: - PTC = Resistance value of the temperature sensor in the motor in ohm - KTY84 = °C - Switch = Voltage at the measurement input in mV - PT1000 (default) = °C - No motor temperature sensor selected = 0	5015
Thermal Model Motor %	Actual thermal motor image in %	5016
Actual Device Temperature °C	Actual device temperature	5002
Thermal Model Device %	Actual thermal device image in %	
Actual Heatsink Temperature R	Actual resistance value of the heatsink temperature sensor (PTC)	5015
Actual Control Voltage V	internal control voltage	5002
Mains Voltage L1 V	Actual voltage on L1	5002
Mains Voltage L2 V	Actual voltage on L2	5002
Mains Voltage L3 V	Actual voltage on L3	5002
EEPROM - Data Read Values	change to the submenu A.6.1	5015

Display	Description	CAN param.
A6.1 EEPROM data		
Number Starts Total	Sum of the implemented starts	5015
Starting Time Total s	Sum of the accumulated start times	5015
Braking Time Total s	Sum of the accumulated braking times	5015
Bypass Time Total s	Sum of the accumulated time while the device was in bypass.	5015
Standby Time Total s	Sum of the accumulated time in standby.	5015
Operating Time Total s	Entire operating time of the device	5015

Display	Description	CAN param.
Maximal Starting Current A	Maximum measured current during start-up	5014
Maximal Braking Current A	Maximum measured current during braking	5014
Maximal Bypass Current A	Maximum measured current during bypass operation	5014
Maximal Mains Voltage V	Highest measured mains voltage	5014
Maximal Motor Voltage V	Highest measured motor voltage	5014
Maximal Starting Time s	Longest measured start time	5014
Maximal Braking Time s	Longest measured braking time	5014
Maximal Device Temperature °C	Highest measured device temperature	5014
Max. Heatsink Temperat. R	Highest measured heatsink temperature. The display value is the resistance value of the temperature sensor (PTC resistance) on the heatsink.	5014
Max. Motor Temp. X Y	Highest measured motor temperature. According to selected temperature sensor X, the display value corresponds to YY: - PTC = Resistance value of the temperature sensor in the motor in ohm - KTY84 = °C - Switch = Voltage at the measurement input in mV - PT1000 (default) = °C - Thermal motor representation = buffer in %	5014
Mains Quality Start/Brake Synchron.	Mains quality during start and braking	5015
L1/L3 Total		5016
Device Fault Memory1	Indicates the content of the fault storage "memory position 1" in the decimal format. By decoding in the binary format, recoding can be implemented on the stored combined faults: 0 = no fault 1 = fault occurred bit 0 = Mains voltage phase symmetry 1 = Mains voltage outside of tolerance 2 = Short-circuit between L1 T1 3 = Short-circuit between L3 T3 4 = Free-wheeling arm short-circuit 5 = Test braking failed (motor voltage) 6 = Test braking failed (motor current) 7 = Test braking failed (motor standstill) 8 = Internal memory error 9 = Ignition fault braking circuit thyristor 10 = Interruption in the free-wheeling arm 11 = Operating state not defined 12 = Not occupied 13 = Control input defective 14 = Control output relay defective 15 = No motor current 16 = Motor overload 17 = Internal device error 18 = Internal EEPROM memory error 19 = Short-circuit between L2 T2 20 = Bypass relay L1 does not close 21 = Bypass relay L3 does not close 22 = Firing L1 or L3 failed	5012
Device Fault Memory2	Indicates the content of the fault storage "memory position 2" in the decimal format. See device fault save Pos.1.	5012
Device Fault Memory3	Indicates the content of the fault storage "memory position 3" in the decimal format. See device fault save Pos.1.	5012
Device Fault Memory4	Indicates the content of the fault storage "memory position 4" in the decimal format. See device fault save Pos.1.	5012
Device Fault Memory5	Indicates the content of the fault storage "memory position 5" in the decimal format. See device fault save Pos.1.	5012

Display	Description	CAN param.
Combined Fault Memory1	Indicates the content of the fault storage "memory position 1" in the decimal format. By decoding in the binary format, recoding can be implemented on the stored combined faults: 0 = No fault 1 = Fault has occurred bit 0 = Maximum start-up time exceeded 1 = Start-up time optimisation not possible 2 = Tool rotational speed deviates from setpoint speed 3 = Motor over-temperature 4 = Braking time optimisation not possible 5 = Mains phase failure 6 = Heatsink temperature 7 = Maximum braking time exceeded 8 = Maximum device over-temperature exceeded 9 = New start attempt exceeded at asymmetry of the zero-crossing 10 = Start input during test braking activated	5012
Combined Fault Memory2	Indicates the content of the fault storage "memory position 2" in the decimal format. See combined fault save Pos.1.	5012
Combined Fault Memory3	Indicates the content of the fault storage "memory position 3" in the decimal format. See combined fault save Pos.1.	5012
Combined Fault Memory4	Indicates the content of the fault storage "memory position 4" in the decimal format. See combined fault save Pos.1.	5012
Combined Fault Memory5	Indicates the content of the fault storage "memory position 5" in the decimal format. See combined fault save Pos.1.	5012

Display	Description	CAN param.
A.7 Status Messages		
A.7.1 Device status		
No Mains Voltage	No mains voltage connected	5003
Warning Temp Mot	Motor warning temperature exceeded	5003
Warning Temp Dev	Device warning temperature exceeded	5003
Tuning Starts	Start time optimisation not possible Setpoint start-up time was not reached.	5003
Tool Speed	Tool speed identified with external sensor	5003
BZ-Relay Closed	BZ relay (operating state) closed	5003
SS-Relay Closed	SS relay (combined fault) closed	5003
GS-Relay Closed	GS relay (device fault) closed	5003
MS_Relay Closed	MS relay closed (motor standstill)	5003
HE-Relay Closed	HE relay (ramp-up end) closed	5003
Hardware Detect	Detection Hardware version internally	5003
Network Qual Br	No braking possible because of mains quality	5003
Testing Data	Testing data is sent (for internal objectives only)	5003
SRS second Brake	Standstill remanence voltage constant post-braking flag (only with P50_0A)	5003
SRS Currentless	Standstill remanence voltage currentless was detected	5003
SRS I-Increase	Standstill remanence voltage rise was detected	5003
SRS - 0-Voltage	Standstill remanence voltage 0V was detected	5003
EEPROM-DATASAFE	Data was stored in the EEPROM. (only with detection of 24V loss)	5003
Start End Relay	Status diagnostics HE relay	5003
Standstill Relay	Status diagnostics STS relay	5003
Diag. Device Err	Status diagnostics GS relay	5003
Extern. Speed A1	Status external speed input - Channel A	5003
Extern. Speed B1	Status external speed input - Channel B	5003
Ext. Standst. A1	Status external input standstill own monitoring unit - Channel A	5003
Ext. Standst. B1	Status external input standstill monitoring unit - Channel B	5003
Start/Stop A ON	Status input start/stop - Channel A	5003
Start/Stop B ON	Status input start/stop - Channel B	5003
SRS Constant	Standstill remanence voltage constant was detection	5003
No Standstill	No standstill detection during monitoring time	5003
Standstill OK	Standstill detection during monitoring time	5003
Standst. I-Brake	Braking current standstill was detection	5003
Standst. U-Rema.	Standstill remanence voltage was detection	5003

8.4.2 Programming mode

In order to open the programming menu, confirm the Programming mode (↵). A password (default "2") must be entered. For this purpose, turn the rotating encoder to the right or left (↔) until the correct password is displayed. Then press the rotation knob shortly (↵) and confirm the password with that.

8.4.2.1 Change of parameter values

Scroll in the programming menu (↔) until the required group is displayed and confirm (↵) with button. Select with (↔) the corresponding parameter and confirm (↵). As a result of short pressing (↵) of the button, a switch is made into the Change mode and the cursor flashes. The selected parameter is shown with its value in the display. Change the value with the rotating encoder (↔) until the setpoint value is reached. As a result of short activating (↵) the button, the cursor changes from the ones digit to the tens digit and the parameter value can then be changed in 10 steps. By further pressing (↵) of the button, the cursor is set to the next digit or reset to the ones digit again. The change mode can be left again through long pressing (↵) the button, the cursor does not flash any longer. The display changes back to the parameter level. Now a further parameter can be selected and changed. For saving the changes or leaving the Change mode, press the button (↵) for a longer time (>1 sec). In the display there appears "Save parameters".

Set the required action

no = Leave without saving

Yes = Save parameter value and leave

by rotating the rotating encoder (↔) in and confirm by short pressing the button (↵). The display changes back into the higher-level menu group which was previously selected. In order to leave the programming menu, select the menu item "Leave Programming mode" (↔) and confirm (↵) briefly or press the button (↵) for a longer time. The display changes back into the main menu or into the Standby mode.



Warning note

If "No" is confirmed at "Save parameters", the parameter menu is then exited without saving the changes.

If the rotating encoder 60s is not activated in the programming mode and/or change mode, then the programming mode is exited without saving. A change is made into the main menu.

8.4.2.2 Expert mode

In order to reach the Expert mode and thus to change the extended parameter set, the input of an additional password is necessary. The change of these parameters presupposes very good system know-how and should be implemented with great caution. The operation and the change of parameters is implemented as described under 8.4.2.1.

8.4.3 Description of the adjustable parameters

8.4.3.1 Motor data

Display	Description	min	max	Default	CAN param.	User adjustments
B.1 Motor data						
Rated Motor Current A	Motor rated current according to nameplate resp. device rated current (I_{Mot}). In case of factory settings or factory reset, the parameter motor rated current corresponds to the device rated current. This parameter refers to the parameter 4014 (System Parameters).	$I_{rated}^{1} \times 0.1$	I_{rated}^{1}	I_{rated}^{1}	4032	

8.4.3.2 Soft start parameter

Display	Description	min	max	Default	CAN param.	User adjustments
B.2 Start-up parameter						
Motor StartMode 0=U 1=IO 2=lwO	Selection of the start mode as the motor starts. Soft start through voltage ramp or current control. 0 = U -> voltage ramp 1 = IO -> current control with start period optimisation 2 = lwO -> current control without start period optimisation	0	2	1	4002	
Starting Current StrtMode1/2 A	Setpoint value of the start current with start mode 1 or 2, see selection parameter StartMode 4002.	$1.5 \times I_{Mot}^{2)}$	$6 \times I_{Mot}^{2)}$	$4 \times I_{Mot}^{2)}$	3003	
Min. Start Curr StrtMode1/2 A	Minimum possible starting current with start mode 1 or 2, see selection parameter StartMode 4002. The starting current is not controlled below this minimum value.	$1.5 \times I_{Mot}^{2)}$	$5.5 \times I_{Mot}^{2)}$	$3.5 \times I_{Mot}^{2)}$	4059	
Motor Starting Time s	- StartMode 0 "Voltage ramp" - the value correspond to start period - StartMode 1 "Current control with start period optimisation" - the value is the setpoint for start period optimisation. See parameter selection StartMode 400	500	20000	9000	3001	
Max. Start Time StrtMode=0 s	Maximum permissible start period at StartMode 1 and 2. After exceeding, a combined fault is triggered.	0	25000	18000	4034	
Starting Voltage U-Mains x %	Starting voltage in % of the mains voltage only if StartMode 0 "voltage ramp" is selected, see parameter 4002.	40	80	40	3002	
Starting Self-Tuning	After this number of starts, the actual start period value must be shorter than the adjusted start period in parameter 3001. Only if StartMode 1 is selected, see parameter 4002. In case of exceeding, a combined fault is triggered.	3	10	3	4001	
Boost Start 0=Off 1=On	Start with boost-pulse (kickstart). 0 = Off = Boost inactive 1 = On = Boost active	0	1	1	3004	
Boost Start Duration ms	Duration of the boost pulse at start-p.	100	2000	500	4011	
Boost Level if Boost = On %	Boost level during boost pulse at Boost Start = On. - At StartMode 0 " Voltage ramp": Boost level in % of the mains voltage. - At StartMode 1 or 2 " Current control...": Boost level in % of the 6-times rated motor current with reference to parameter 4032.	60	100	70	4010	

1) I_{rated} refers to the parameter 4014 (B.4) motor rated current or device rated current.

2) I_{Mot} refers to parameter 4032 (B.1).

8.4.3.3 Brake parameter

Display	Description	min	max	Default	CAN param.	User adjustments
B.3 Brake parameter						
BrakeMode 0=SO 1=SwO 2=t 3=PA	Selection of the braking type (BA). 0 = SO -> standstill - dependent braking with braking-time optimisation 1 = SwO -> standstill - dependent braking without braking-time optimisation 2 = t -> Time-dependent braking 3 = PA -> Braking with fixed phase angle, see D.6.2 CAN-Param. 4801	0	2	0	4003	
Motor Braking Time ms	- At BrakeMode 0 "Standstill-dependent braking with braking time optimisation" - the value is the setpoint for braking time optimisation.. - At BrakeMode 2 "Time-dependent braking" - the value correspond to the braking time. See Parameter BrakeMode 4003.	500	40000	8000	3006	
Set Point Brake Current A	The setpoint value of the braking current at BrakeMode 0 or 1, see parameter selection 4003.	$1.5 \times I_{Mot}^{(2)}$	$6 \times I_{Mot}^{(2)}$	$4 \times I_{Mot}^{(2)}$	3005	
Minimal Braking Current A	Minimum possible braking current at BrakeMode 0 or 1, see selection parameter 4003. The braking current is not controlled below this minimum value. Thus a deceleration of the motor is ensured.	$1.5 \times I_{Mot}^{(2)}$	$5.5 \times I_{Mot}^{(2)}$	$1.5 \times I_{Mot}^{(2)}$	4060	
Monitoring Time Int. Brake ms	Monitoring of the braking time with internal standstill monitoring unit. The standstill must be detected within this time. Only in case of BrakeMode 0 or 1, see parameter selection 4003.	1000	25000	10000	4005	
Max Second Brake Time ms	Post-braking time after motor standstill is detected only with braking type 0 or 1, see parameter selection 4003.	1000	20000	10000	4013	
Selection Brake Termination	Activation or deactivation of the braking interruption, in order to perform a new motor start during a braking period, or to end the braking sequence completely before a new start is performed. 0 = No start during braking possible: Brake period will be finished before a new start is performed. 1 = Start during braking possible: Braking is interrupted, new start is possible immediately.	0	1	1	4030	
Comb.Fault 3x no Standstill	Device fault triggered if no standstill identified 3x. 0 = inactive 1 = active	0	1	1	4021	
Ext. Standstill Monitor	Standstill recognition with external standstill monitoring unit. 0 = inactive 1 = active	0	1	0	4004	
Ext. Brake Time Monitor. ms	Monitoring of the braking time with external standstill monitoring unit. The standstill must be identified within this time. Only in case of external standstill monitoring unit.	1000	25000	10000	4015	
Ext. Standstill Signal ms	Measuring time of the external standstill signal after disconnection of the braking current. Only in case of external standstill monitoring unit.	1000	20000	6000	4031	
Test Braking Delay ms	In case of several devices in a system, the test braking is triggered with a delay time. Delay time = Delay test braking * switch position on the CAN address selection switch - 1 (0 = 0).	0	20000	3000	4080	

1) I_{rated} refers to the parameter 4014 (B.4) motor rated current or device rated current.

2) I_{Mot} refers to parameter 4032 (B.1).

8.4.3.4 System parameter

Display	Description	min	max	Default	CAN param.	User adjustments
B.4 System data						
ReferenceCurrent 0=M/1=D	Stipulates the reference value to which the maximum start current and braking current refers. 0 = Motor -> Motor rated current (default) 1 = Device -> Device rated current The start and braking current is calculated from the rated current.	0	1	0	4014	
Device Warning Temperature °C	If the device temperature reaches the adjusted value, a warning is output. (Default 70°)	40	80	70	4026	
Sensor Motor Temperature	Type of the motor temperature sensor (PTC/KTY84/Switch) or calculation of thermal motor image. 0 = PTC 1 = KTY84 2 = switch 3 = PT1000 4 = thermal motor image(default)	0	4	4	4012	
Motor Warning Temperature °C	If the motor temperature reaches the adjusted value, a warning issued. Only active with KTY and PT1000 and motor protection	80	190	135	4023	
Trip Temperature Motor °C	If the motor temperature reaches the adjusted value, a combined fault issued. Only active with KTY and PT1000 and motor protection (Default 155°)	120	200	155	4022	
Re-Start Temp. Motor °C	If the motor temperature falls below the re-start temperature, the "Motor over-temperature combined fault" can then be reset. Only active with KTY and PT1000 and motor protection (Default 130°)	80	160	130	4024	
Trip Class Start Braking	Release class for the calculation of the thermal motor monitoring for start-up and braking. Only in case of thermal motor image active.	2	40	30	3011	
Trip Class Stdby Bypass	Release class for the calculation of the thermal motor monitoring in standby and bypass operation.	2	40	20	3012	
Cooling Down Time Motor s	Cool-down time of the motor in standby and bypass operation	10	18000	2100	3013	
Deactiv. Motor Protection	Temperature monitoring of the motor is deactivated. The adjustment in CAN Parameter 4012 is ineffective with that. 0 = Motor protection active (default) 1 = Motor protection inactive	0	1	0	4033	
External Tool Speed	Activation of the external recording of the tool rotational speed. 0 = Tool speed not recorded (default) 1 = tool speed recorded	0	1	0	4035	
Min. Tool Speed	If the tool speed falls below the minimum tool rotational speed, a combined fault is triggered.	1	10000	2500	4078	
Monitor Duration Tool Spd ms	Measuring time in which no pulse of the tool pulse generator should be recorded. Standstill identification.	6000	12000	6000	4016	
Tool Speed Tolerance %	If the tool speed decreases in bypass status and falls below the tool speed tolerance, a combined fault is triggered (belt break identification).	50	95	80	4076	

Display	Description	min	max	Default	CAN param.	User adjustments
Opts Operating State relay	Assignments of the operating states which are displayed on the BZ signal relay. (Default 464, binary coded: 0000111010000) 0 = status is not displayed 1 = status is displayed bit 0 = Waiting time 1 = Determine device data 2 = Initialise EEPROM 3 = Measure mains frequency 4 = Implement test braking 5 = Standby 6 = Soft start 7 = Bypass 8 = Braking 9 = Device or combined fault 10 = Device data fault 11 = EEPROM fault 12 = Test program	0	8191	464	4077	
Options Combined FaultRelay	The assignment of the combined faults which are displayed with the SS signal relay. (Default 2047, binary coded: 11111111111) 0 = Fault is not displayed 1 = Fault is displayed bit 0 = Maximum start time exceeded 1 = Start time optimisation not possible 2 = Tool speed deviates from setpoint speed 3 = Motor over-temperature 4 = Braking time optimisation not possible 5 = Mains phase failure 6 = Heatsink temperature 7 = Maximum braking time exceeded 8 = Maximum device over-temperature exceeded 9 = New start attempt exceeded at asymmetry of the zero-crossing 10 = Start input during test braking activated	0	2047	2047	4029	
Light Period LC-Display s	Lighting duration of the LCD background lighting. (Default 30s)	5	120	30	3007	
Status Display Main Menu	Selection of the status display line in the main menu. The current values of the selected parameter are displayed. 0 = display shows (default): Standby = standstill OK; Start-up, bypass and braking = motor current of the respective operating mode; 1 = Motor current; 2 = Motor voltage; 3 = Mains voltage; 4 = Device operating status; 5 = Device temperature; 6 = Thermal device image; 7 = Heatsink temperature; 8 = Motor temperature (PTC, KTY84, thermoswitch, PT1000 therm. motor image);	0	6	0	3014	
Language	Display language selection: 0 = German 1 = English	0	1	0	3010	

8.4.3.5 CAN Parameters

Display	Description	min	max	Default	CAN param.	User adjustments
B.5 CAN parameter						
CAN-open Baudrate kB	Speed of the CAN-Bus (transmission rate)	0	1000	125	4037	
CAN-open Node ID Adresse 0	Address setting CANOpen Node ID 0	1	127	57	4036	
CAN-open Node ID Adresse 1	Address setting CANOpen Node ID 1	1	127	58	4044	
CAN-open Node ID Adresse 2	Address setting CANOpen Node ID 2	1	127	59	4045	
CAN-open Node ID Adresse 3	Address setting CANOpen Node ID 3	1	127	60	4046	
CAN-open Node ID Adresse 4	Address setting CANOpen Node ID 4	1	127	61	4047	
CAN-open Node ID Adresse 5	Address setting CANOpen Node ID 5	1	127	62	4048	
CAN-open Node ID Adresse 6	Address setting CANOpen Node ID 6	1	127	63	4049	
CAN-open Node ID Adresse 7	Address setting CANOpen Node ID 7	1	127	64	4050	
CAN-open Node ID Adresse 8	Address setting CANOpen Node ID 8	1	127	73	4051	
CAN-open Node ID Adresse 9	Address setting CANOpen Node ID 9	1	127	74	4052	
CAN-open Node ID Adresse A	Address setting CANOpen Node ID 10	1	127	75	4053	
CAN-open Node ID Adresse B	Address setting CANOpen Node ID 11	1	127	76	4054	
CAN-open Node ID Adresse C	Address setting CANOpen Node ID 12	1	127	77	4055	
CAN-open Node ID Adresse D	Address setting CANOpen Node ID 13	1	127	78	4056	
CAN-open Node ID Adresse E	Address setting CANOpen Node ID 14	1	127	79	4057	
CAN-open Node ID Adresse F	Address setting CANOpen Node ID 15	1	127	80	4058	

8.4.3.6 Expert mode

Display	Description	min	max	Default	CAN param.	User adjustments
B.6 Expert parameter						
B.6.1 Start-up parameter						
I-Amplification Start	I-content start current regulation only in case of current control.	0	5	1	4006	
P-Amplification Start	P-content start current regulation only in case of current control.	0	20	6	4007	
Sampling Time Start	Sampling time of the feedback loop only in case of current control.	1	30	19	4081	
Current Lower Limit Strt %	In start operation, an device fault is caused after expiry of the measuring time and undershooting the current lower limit.	0	100	5	4508	
Mon. Time Current Low-Limit ms	Measuring time of the current lower limit in start operation after which an device fault is triggered.	0	10000	300	4509	
Current Upper Limit Strt A	In start-up operation, an device fault is triggered after expiry of the measuring time and exceeding the current upper limit.	0	10000	10000	4510	
Monitor. Current Upper Lim ms	Measuring time of the current upper limit in start operation after which an device fault is triggered.	0	10000	300	4511	
Current Increase Temperature	In case of motor temperatures less than 40°C, an start current increase is implemented to at least 4x the motor current. Only in case of KTY or PT1000 motor protection measurement and current regulation. 0 = motor-temperature current increase Off 1 = motor-temperature current increase On	0	1	0	4079	
Restarts Unbal. ZeroCrossing	Restart attempts at imbalance of the zero-crossing	1	100	10	4526	
Phase Angle Start ms	fixed phase angle.	0	999	999	4800	
Correction Angle Softstart ms	Correction angle is added for the fixed phase angle L1.	0	250	0	4802	
B.6.2 Brake parameter						
Threshold Motor Standst. mV	Threshold value for the identification of the voltage standstill. A change affects the identification of the motor standstill. *	0	10000	4000	4069	
I-Amplification Brake	I-content braking current regulation. Only in case of current control	1	10	9	4008	
P-Amplification Brake	P-content braking current regulation. Only in case of current control	1	50		4009	
Current Low Lim. Brake %	In braking operation, an device fault is caused after the measuring time and the undershooting of the current lower limit.	0	100	5	4516	
Monitor. Current Low Limit ms	Measuring time of the current lower limit in braking operation after which an device fault is triggered.	0	10000	500	4517	
Current Hi Limit Brake A	In braking operation an device fault is triggered after expiry of the measuring time and exceeding the current upper limit.	0	10000	10000	4518	
Monitor. Current Hi Limit ms	Measuring time of the current upper limit in braking operation after which an device fault is triggered.	0	10000	300	4519	
Mode Delay Time Brake	With this parameter, the mode of delay time (VZA) between motor release and control activation of the braking current is selected. 0 = self-optimisation 1 = fixed delay time 2 = motor-voltage-dependent	0	2	1	4017	

* See warning note on Page 37.

Display	Description	min	max	Default	CAN param.	User adjustments
Delay Time Brake ms	Delay between motor release and activation of the braking current at Mode Delay time 1 "fixed delay", see parameter 4017.	0	4000	300	4018	
Threshold Motor Voltage V	Threshold value of the motor voltage at Mode Delay time 2 "motor voltage-dependent", see parameter 4017.	30	200	60	4019	
Debounce Time Brake Rel. ms	Duration of the bounce time of the braking relay. Close time period between braking relays and control activation of the braking current.	50	1000	50	4020	
Standstill Incr. Delta-t ms	Time period (dt) of the voltage rise with standstill recognition through remanence voltage.	4	200	40	4038	
Standstill Incr. Delta-U mV	Level (du) of the voltage rise with standstill recognition through remanence voltage.	200	20000	20000	4039	
Standstill 0V Delta t ms	Time period (dt) of the 0-line undershooting with standstill recognition through remanence voltage.	4	1000	15	4040	
U-Remanence Cons Delta t ms	Time (dt) in which the remanence voltage must remain constant after motor standstill.	20	5000	1000	4041	
U-Remanence Cons Window mV	Threshold value (u) minimum voltage in which the standstill identification works through remanence voltage.	500	10000	10000	4042	
Toler. Remanence Voltage mV	Permissible voltage tolerance of the standstill recognition through remanence voltage.	0	500	100	4043	
U-Rem Values Out Of Tolerance	Number of values which may not be in the permissible tolerance of the standstill recognition through remanence voltage. *	0	1000	429	4075	
Sensitivity Curr Standstill	Sensitivity of the current standstill identification 0 = Off 1 = Medium 2 = High	0	2	2	4522	
Remanence Volt. Standst. 0V	Standstill 0V with standstill identification through remanence voltage. 0 = standstill identification through remanence voltage Off 1 = standstill identification through remanence voltage On	0	1	1	4524	
Braking Time level 1	Braking Time level 1	0	7000	2000	4082	
Braking Time level 2	Braking Time level 2	0	7000	2000	4083	
Braking Time level 3	Braking Time level 3	0	7000	2000	4084	
Braking factor level 2	Braking factor level 2	0	100	70	4085	
Braking factor level 3	Braking factor level 3	0	100	50	4086	
Braking factor level 4	Braking factor level 4	0	100	20	4087	
Phase Angle Brake	fixed phase angle. PE internal.	1600	9500	3000	4801	





Warning note *

The parameters identified with * may be changed only in discussion with PETER electronic. A change affects the identification of the motor standstill. A change can lead to a device failure in the worst case.

Display	Description	min	max	Default	CAN param.	User adjustments
B.6.3 System parameter						
Mains Switch-off Voltage V	Minimum mains voltage level in the 3 phases, which is identified as a switch-off threshold of the mains voltage. After the expiry of the Monitoring Time U-mains, Parameter 4501, a combined fault is triggered.	0	700	20	4507	
Monitoring Time U-mains ms	Measuring time of the mains disconnection up to the activation of a combined fault.	0	10000	250	4501	
Limit Phase Sym. Bypass %	Phase symmetry threshold in bypass operation. If the limit value is exceeded and after the expiration of the acquisition time "Monitor. Phase Sym Mains low", see parameter 4506, a device fault is triggered.	0	1000	18	4504	
Current Low Lim. Bypass %	In bypass operation, a device fault is caused after the measuring time expiry and undershooting the current lower limit.	0	100	0	4512	
Monitor. Current Low Limit ms	Measuring time of the current lower limit in the handling mode after which an device fault is triggered.	0	10000	300	4513	
Current Hi Limit Bypass %	In bypass operation an device fault is triggered after expiry of the measuring time and exceeding the current upper limit.	0	600	600	4514	
Monitor. Current Hi Limit ms	Measuring time of the current upper limit in the handling mode after which an device fault is triggered.	0	10000	1000	4515	
Time Kon.Thermal Image Bypass %	Calculation of the evaluation time (% of the fixed time constant) for the device temperature image in bypass operation.	10	100	100	4520	
Curr.Kon.Thermal Image Bypass %	Calculation of the evaluation current (% of the current constants) for the bypass operation device temperature image.	10	100	80	4521	
Password 1	Access password to the Programming mode.	0	200	2	3008	
Password 2	Access password to the Expert mode	0	200	195	3009	
System reset						
System Reset Perform	All parameters are set according to the factory default setting. - Carry out reset to default No -> Leave reset menu. - Carry out reset to default Yes -> Device is set factory default setting. - Reset CAN communication - Reset fault storage - Reset max. values and operating data	0	4	0	3000	

8.4.4 Fault mode

If a fault occurs (see Chapter 12. on Page 45), the display changes into the Fault mode. According to the cause of malfunction, the display indicates the corresponding fault group, combined fault or device fault, output and the corresponding reason for malfunction.

By a short pressing of the button , a change is made into the status message mode. The groups combined fault, device fault or device status can be selected with the rotating encoder . Activate the selected group with the button . Now you can scroll between the corresponding messages of the selected group.

For leaving, press the button  shortly and a change is made back into the group menu. The status message mode is ended by long pressing and a return is made into the fault mode.

As a result of long pressing of the button  in Fault mode, a change is made into the main menu. Further operation is described under Chapter 8.4.1.2 on Page 15.

Display Fault mode

Fault mode	-- Device in fault mode
Status parameter	-- Submenu status paramter

If the button  is held pressed long, the main menu is left again and a return is made into the Fault mode.

8.4.4.1 Fault Messages

Display	Description
A.7.2 Combined fault	
Max. Start Time	maximum start time exceeded
Max. Opt. Start	Start time optimisation not possible
Tool Speed	Tool speed deviating from setpoint speed
Max. Totor Temp.	maximum permissible motor over-temperature exceeded
3x No Stillstand	Braking time optimisation not possible
Failure L1 L2 L3	Failure of mains power supply L1, L2, L3
Max Heatsink Tmp	maximum permissible heatsink temperature exceeded
Max Braking Time	maximum braking time exceeded
Max.Device Temp.	maximum device temperature of the thermal image exceeded
Restart Cycles	maximum number of new start attempts exceeded at asymmetry of the zero-crossing
Act.Start Testbr	If the start input is activated during test braking, the combined fault signal relay output is open for the duration of the test braking, the red LED flashes
A.7.3 Device fault	
Phase Symmetry	Mains voltage phase symmetry
Voltage Level	Mains voltage less than lower limit
Zero-Crossing L1	Short circuit between L1 T1
Zero-Crossing L3	Short circuit between L3 T3
Zero-Crossing L2	Free-wheeling arm short-circuit
Motor Voltage	Test braking failed (motor voltage)
CurrentAutoTunin	Test braking failed (motor current)
Stop Threshold	Test braking failed (motor standstill)
RAMTEST	Internal memory error
Curr. Dir. Brake	Incorrect direction of current at the beginning of the braking
Freewheel. Fault	Interruption in the free-wheeling arm
Undef. Condition	Operating state not defined
	free
Diagnosis Input	Control input defective
Diagnosis Output	Control output relay defective
Under Current	No motor current
Over Current	Motor overload
Device Data	Internal device error (electronic, component parts, ...
EEPROM Diagnosis	Internal EEPROM memory error
Phase L2 Relay	Short-circuit between L2 T2, relay in phase L2 does not open
Bypass Fault L1	Bypass relay L1 does not close
Bypass Fault L3	Bypass relay L3 does not close
Firing FaultL1L3	Firing L1 or L3 failed

8.4.5 Operating sequence

8.4.5.1 Normal operation

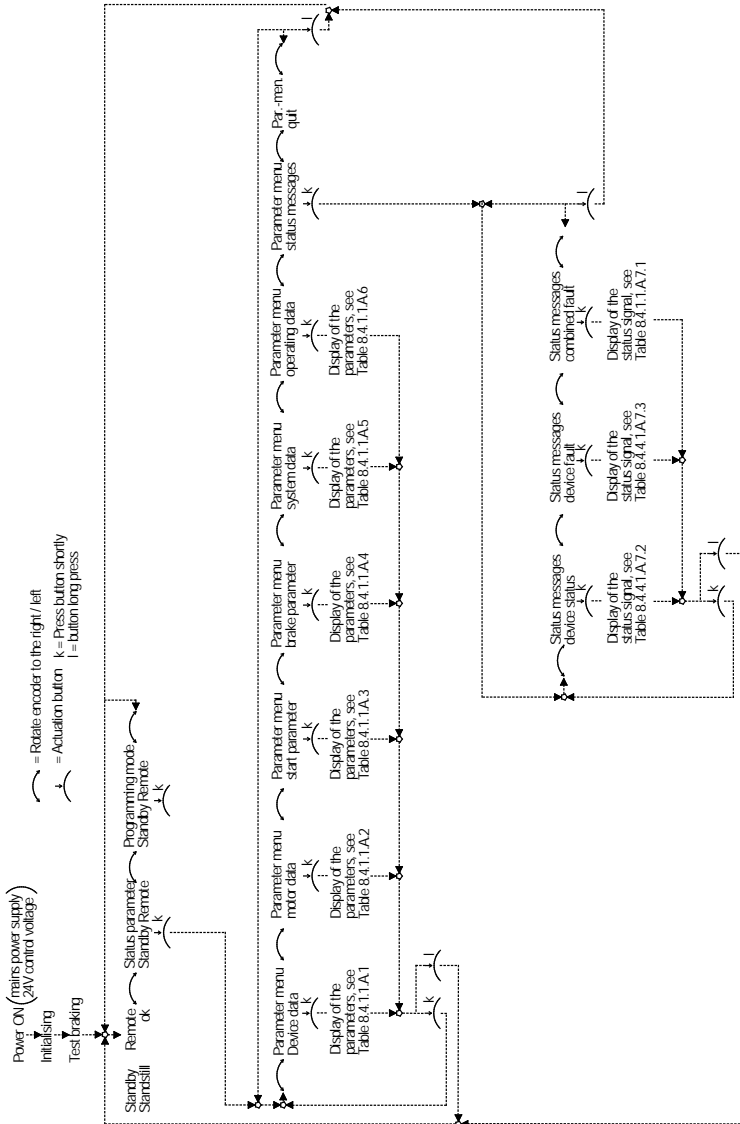

8.4.5.2 Programming

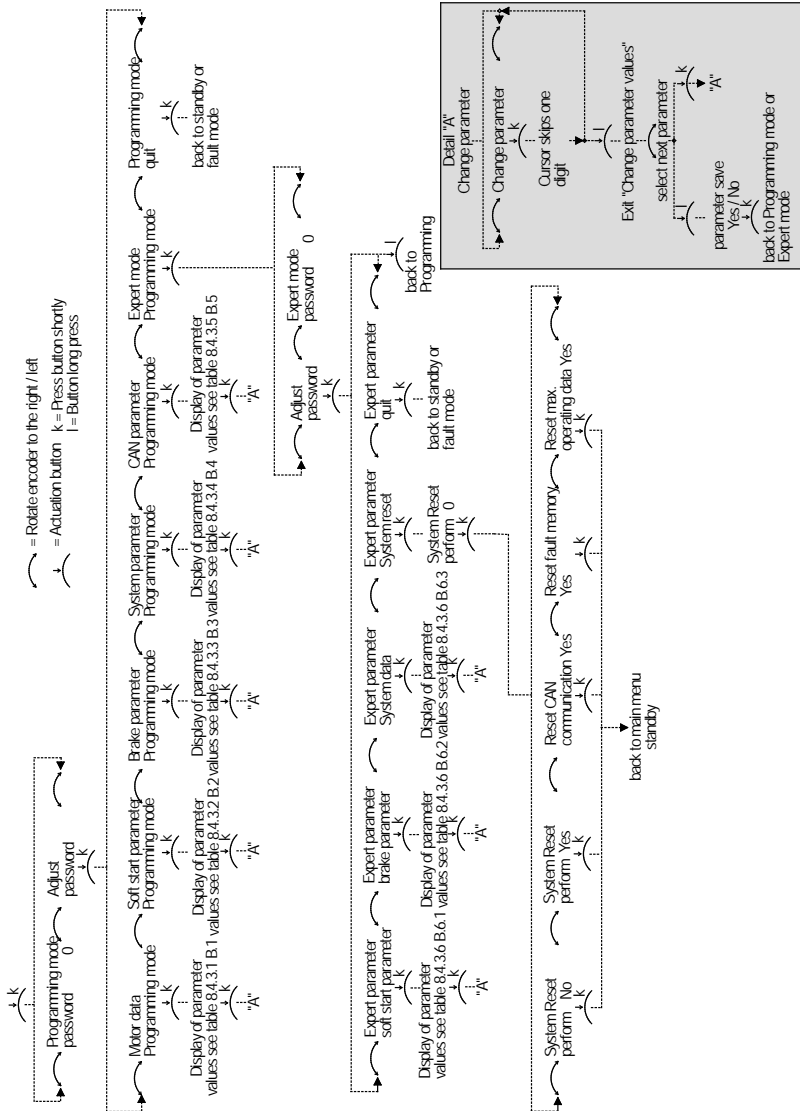

8.5 System reset

A reset to factory default setting, setting all parameters into the default status, can be implemented in three ways.

- a. The VC II S ... can be set by simply wiring the reset input into the default status. Terminal 1 "L+" must be connected for 15s with terminal "FQ" for this purpose. If the device is reset to the default condition, then the yellow LED lights up briefly. All adjustments are now set to the default value.
- b. With the LC operator panel, the menu item system reset is selected in the Programming mode, in the Expert mode submenu and confirmed with "1". reset to factory default setting reset is implemented and the yellow LED lights up shortly. All adjustments are set to the default values.
- c. Over CAN bus, the CAN parameter 3000 is set to "1". All adjustments are then set to the default value.

9. Starting and stopping

9.1 Soft start

The device series VC II S is adjusted as default to "Start with current limit". Over the LCD operator panel or the CAN bus interface, a start with voltage ramp can also be selected, as well as the Boost function switched on.



Note:

If the start input is activated during test braking, then the signal relay output "Combined fault" opens and the red LED flashes. No start is implemented! After the test braking, the VC II S changes into Standby mode and the signal relay "Combined fault" closes again. In order to now enable a start to be implemented, the start input must be deactivated and activated again.

Start with current limit:

The motor is accelerated to motor rated speed at the learned current limit $1.5...6 \times I_{rated} \text{ (device)}$ in the specified soft start time (default value 9s).

The first start is implemented with $4 \times I_{rated} \text{ (device)}$. According to the mass inertia of the motor and the tool connected to the motor, after a maximum of 3 starts the start current adjusts to an optimum start current between $1.5...6 \times I_{rated} \text{ (device)}$

The start current is optimised after every start. The last start parameters remain stored, also in case of mains voltage failure.

After a tool change, the optimal adjustment is achieved again after a maximum of 3 starts.

In case of the II VC S devices, the function can be adjusted such that a current pulse (boost) with every soft start is switched to the motor, over CAN bus or the LCD operator panel. This enables the secure start of motors, even with current limits adjusted low.

The boost pulse is adjusted (default values) to a duration of 0.5s and to a level of $4.2 \times I_{rated} \text{ (device)}$. The parameters can be adapted over CAN bus or the LCD operator panel.

All parameters for the "Soft start with current limit" can be adapted over CAN bus or the LCD operator panel.

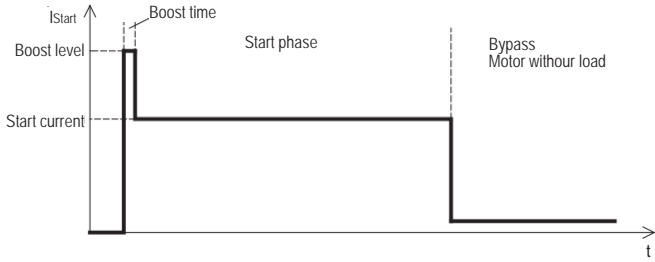

Diagram for start with current limit and boost



Warning note:

If the current limit is adjusted too low, the motor will not accelerate to the full rotation speed, rather it will remain at an intermediate speed. The device will interrupt the start process after 18s (default value) and change into the combined fault mode, in order not to overload device and motor. After a fault reset, the motor can be started with the newly learned start parameters.

Start with voltage ramp

The motor is time-controlled with an adjustable voltage ramp in the range from 0s to 20s and an adjustable start voltage U_{Start} 40% to 80% of the rated voltage started. In order to adjust the optimal start characteristic, you should implement several test runs.

With this start mode, no automatic optimisation occurs.

All parameters for "Soft start with voltage ramp" can be adapted over LCD operator panel and CAN bus.

The soft start time should always be selected as short as possible in order to keep the thermal stress of device and motor low. In case of good soft start characteristics, this results in short times up to the closing of the bypass relays and, with that, low heating levels of the power semiconductors and the motor. This is especially important with high starting duty or high switching frequency. The soft start time must be adjusted, however, so that the motor has reached its rated speed before the internal bypass relays close.

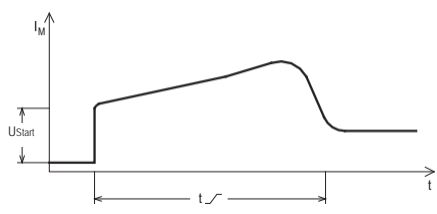

Diagram for start with voltage ramp

Start with boost function:

If the function "Soft start with boost" is selected over the LCD operator panel and CAN bus, the motor voltage is increased at the beginning of the soft start for a short pulse, whose level and time-related duration can be adjusted over the LCD operator panel or CAN bus. This function produces an increased breakaway torque in the drive and enables the starting of drives with high brake torques in standstill.

After that, the soft start is continued with the adjusted voltage ramp or the adjusted start current.

With the start mode "Voltage ramp", no automatic optimisation occurs.

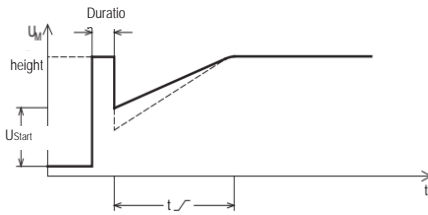

Diagram for start with voltage ramp and boost

9.2 Braking

The motor is braked at the adjusted current limit $1.5..6 \times I_{\text{rated (device)}}$.

The first braking operation is implemented with $3 \times I_{\text{rated (device)}}$. According to the mass inertia of the motor and the tool connected to the motor, after a maximum of 3 braking operations, the braking current adjusts to an optimum braking current between $1.5..6 \times I_{\text{rated (device)}}$.

The braking current is optimised after every braking operation. The last braking parameters remain stored, also in case of mains voltage failure.

After a tool change, the optimal adjustment is achieved again after a maximum of 3 braking operation.

All parameters related to "Braking" can be adapted over the LCD operator panel or CAN bus.

9.3 Safety time

If no standstill is identified after braking has been implemented, the safety time and/or unbraked rundown time runs out. The output contact of the standstill signal remains open to the end of the safety time (e.g. prevents the opening of a protection door). The unbraked rundown time is the time until the standstill is reached securely with the drive coasting to a stop.



Attention: Electric shocks can be fatal!

Even if the motor stops, it is **not** isolated galvanically from the network.



Warning note:

It is to be ensured that the indicated maximum switching frequency is not exceeded by a start and braking on 2 min. (test conditions to DIN EN 12750).

The bypass mode enables the cooling of the power semiconductors!

10. Thermal overload protection

The device series VC II S monitors the motor and device temperature.

10.1 Motor temperature monitoring

The type of motor overload detection can be set via the system parameter "Motor temperature monitoring" (CAN parameter 4012). A motor protection is always guaranteed by temperature sensors or a thermal motor image.

10.1.1 Selection motor temperature sensor

A motor temperature switch, a motor PTC, a motor KTY84 or a PT1000 can be connected. Over CAN bus, a prior warning can be output as soon as the motor has reached the set-adjusted pre-warning temperature. The device enters the fault mode Collective fault if the motor exceeds the set shutdown temperature. This can be set with the system parameter "Switch off motor °C" (CAN-Param 4022).

If the motor temperature does not have to be monitored, a motor sensor can be dispensed with. TF- and TF+ must then be bridge-connected and a thermoswitch must be programmed over the parameterisation. Alternatively, a 1100 Ohm resistance can be connected between TF+ and TF-.

10.1.2 Thermal motor image

VC II S incorporates thermal overload protection for the motor. The thermal motor protection can be selected in the system parameter "Motor temperature monitoring". A current sensor is used to detect the motor current and calculate a thermal image of the motor.

The thermal image can be viewed as a buffer memory that fills up at a correspondingly high current flow and empties at a correspondingly low current flow. If the buffer memory is full, this means that the motor is thermally overloaded and the combined fault "max. motor temp." (3x flashing) will be output.

The tripping class can be set with the system parameters "Startup/brake tripping class" and "Stby/bypass tripping class". This allows the replication of a motor protection switch.

There is no monitoring of low and ground faults.

In the "Thermal motor image - tripping characteristic" diagram, it can be determined how long the X-fold rated motor current (factor: Actual current/rated motor current) may flow.

The thermal motor image depends on the rated motor current set (motor data parameter "Rated motor current A").

If the motor is thermally overloaded (the buffer memory is 100% full), the combined fault "max. motor temperature" will be output.

Thermal motor image - tripping characteristic

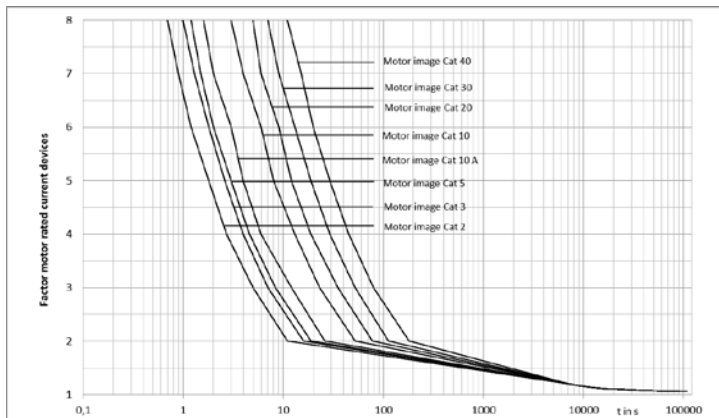

If the thermal capacity has been reached (the buffer memory is 100% full) and the combined fault "max. motor temp." has been triggered, the buffer memory (thermal capacity) must be reduced to 80% before this combined fault can be reset. Before restarting the engine, however, it is recommended to allow the engine to cool down for at least 15% of the set cooling time (system parameter "Motor s cooling time"). The buffer memory (thermal capacity) is then reduced to approx. 50%. If the motor is started before this recommended cooling time has elapsed, there is a risk that the buffer will be refilled immediately and the combined fault "max. motor temperature" will be triggered again during startup.

The cooling curves can be found in the diagram "Thermal motor image - cooling curve". If the combined fault "max. motor temperature" is triggered, the cooling curve for "no actual current flow" must be used.

Thermal motor image – cooling curve

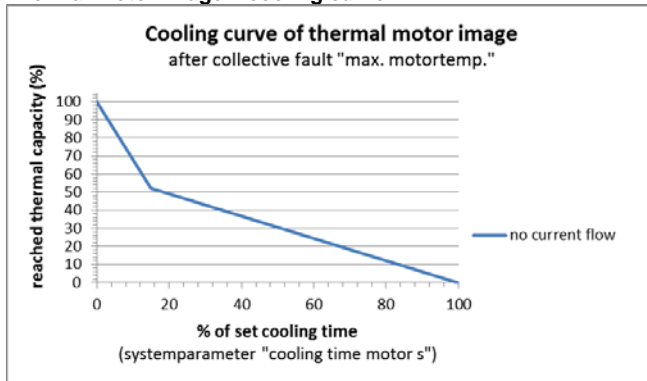

The VC II S has a thermal memory. When switching off the 24V control voltage, the current value of the achieved thermal capacitance is stored. When the 24V control voltage is restored, this value is reloaded. Resetting the thermal image by switching off the 24V control voltage is therefore not possible.

The current value for the thermal motor image can be placed in the status line of the display. When "Motor temperature" is selected, the reached thermal capacity is displayed in%. See chapter 8.4.1.

10.2 Devices temperature monitoring

10.2.1 Thermal device image

VC II S incorporates thermal overload protection for the device. A current sensor is used to detect the operating currents and calculate a thermal image of the device. The tripping value for the device is fixed and corresponds to the thermal capacity of the device. The thermal image can be viewed as a buffer memory that fills up at a correspondingly high current flow and empties at a correspondingly low current flow. If the buffer memory is full, this means that the device is thermally overloaded and the combined fault "max. device temperature" (9x flashing) will be output. In this case, the current in the VC II S is switched off immediately.

The "Thermal device image - tripping characteristic" diagram can be used to determine how long the X-fold device rated current (factor: Actual current/rated device current) may flow.

An example:

22A device, starting time 8s, starting current 88A, braking time 8s, braking current 88A. The X-fold rated device current is calculated from "Actual current / rated device current" = "88A / 22A" = factor 4. According to the diagram, the 88A current may flow for ca. 35 sec. For the given start-up and braking times of 8s, 2 starts and 2 stops (total time 32s) can be performed in immediate sequence. During the third startup, the thermal capacity of the device would then be reached - the combined fault "max. device temperature" is triggered.

Thermal device image - tripping characteristic

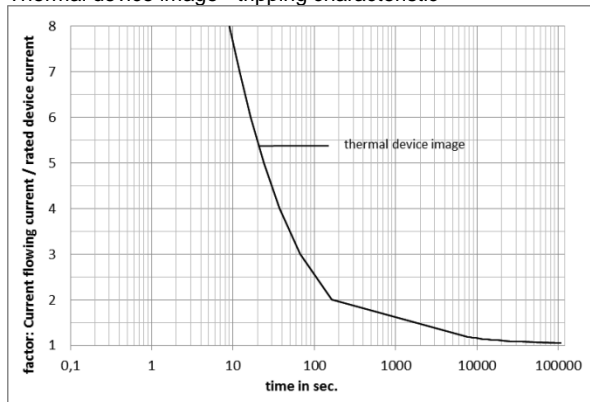

If the thermal capacity has been reached (the buffer memory is 100% full) and the combined fault "max. device temp." has been triggered, the buffer memory (thermal capacity) must be reduced to 80% before this combined fault can be reset. However, before restarting the engine, it is recommended that the unit be allowed to cool off for at least 5 minutes.

The buffer memory (thermal capacity) is then reduced to approx. 50%. If the motor is started before this recommended cooling time has elapsed, there is a risk that the buffer will be refilled immediately and the combined fault "max. device temperature" will be triggered again during startup.

The cooling curves can be found in the diagram "Thermal device image - cooling curve". If the combined fault "max. device temperature" is triggered, the cooling curve for "no actual current flow" must be used.

Thermal device image - cooling curve

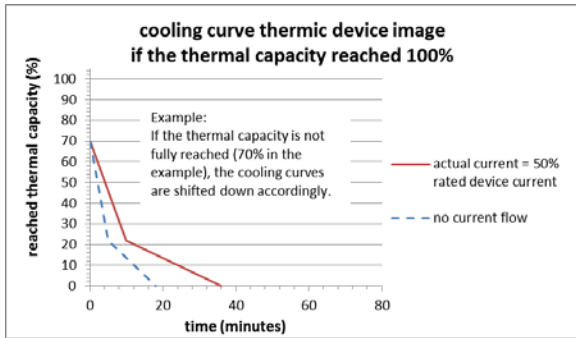
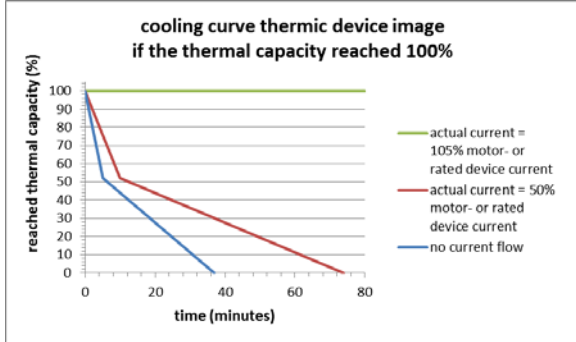

The VC II S has a thermal memory. When the 24 V control voltage is switched off, the current value of the achieved thermal capacitance is stored. When the 24V control voltage is restored, this value is reloaded. Resetting the thermal image by switching off the 24V control voltage is therefore not possible.

The current value for the thermal device image can be placed in the status line of the display. When selecting "Thermal device image", the reached thermal capacity is displayed in%.
 See 8.4.1.1

10.2.2 Heatsink / device temperature

The heatsink temperature of the power module, as well as the device temperature, are monitored with temperature sensors. On reaching the adjusted device warning temperature, this can be adjusted with "Device Warning Temperature °C" (CAN-Param 4026), a warning issued over the CAN bus.

11. Extended, optional operating functions

11.1 External motor standstill monitor

When operating on special or severely disturbed power supplies and in an environment with very high electromagnetic radiation, it is possible that the internal motor standstill detection system does not detect motor standstill. In this case, the motor standstill can be recorded via an external standstill monitor, e.g. VersiSafe. The safety functions and messages in the VC II S that affect the motor standstill are thus retained.

Attention! If the external standstill monitor has a safety level higher than SIL 1 or PL c, the safety level is reduced to the value of the VC II S (SIL 1, PL c).

The standstill monitor is connected in accordance with its commissioning instructions and a safety contact (NO contact) of the external standstill monitor is connected between the terminals X3: 1 (+ 24V) and X3: 6 (ext n0) of the VC II S.

Parameters involved:

"external standstill monitor", CAN parameter 4004

Default value = 0

to activate the external standstill monitor, the value must be set to "1".

"Measuring time external braking time", CAN parameter 4015, unit ms (milliseconds)

Default value = 10,000 (ms)

This time must be selected for 2,000 ms longer than the "braking time/time specification", CAN parameter 3006.

Example 1: If a time specification of 8,000 ms (CAN parameter 3006) is set in braking mode 0 (standstill-dependent braking with braking time optimization), the "Measuring time external braking time" CAN parameter 4015 must be set to 10,000 (ms).

Example 2: If a braking time of 6,000 ms (CAN parameter 3006) is set in braking mode 2 (time-dependent braking), the "External braking time measuring time" CAN parameter 4015 must be set to 8,000 (ms).

NOTE! If the time is set too short, after the third braking the combined fault "3x s. standstill" will be triggered.

"Meas. ext. standstill", CAN parameter 4031, unit ms (milliseconds).

Default value = 6,000 (ms)

During this time, the measured motor terminal voltage (remanent voltage) must be 0. This means that after switching off the braking current, the motor must not turn at least for the set time. A standstill message will be issued only after this time has elapsed.

11.2 Recording the rotational speed of tools

The rotational speed of tools can be monitored with the "n T" input. This input can be used to detect excessive speed deviation and to detect a belt break.

An inductive proximity switch 3-wire PNP, suitable for 24 V DC, must be connected to the VC II S in accordance with the proposed connection.

The sensor disk must be designed so that at the maximum rotational speed of tools the runtime is 1.25 ms.

Rotational speed of tools up to 12,000 rpm can be recorded using the sensor disk recommended below. All setting parameters for the rotational speed of tools are in line with this sensor disk. When using other sensor disks, ensure that the runtime does not fall below 1.25 ms and that the actual minimum rotational speed of tools set with CAN parameter 4078 must be divided by the factor from Table 1.

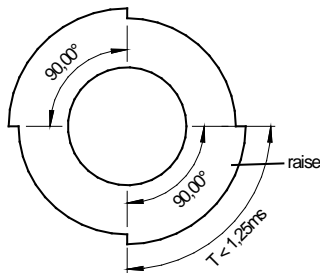

$$f = \text{Tool Speed} / 60 = 12000 \text{ min}^{-1} / 60 = 200 \text{ Hz}$$

$$T = \frac{1}{\text{Number of segments} * f} = \frac{1}{4 * 200 \text{ Hz}} = 0,00125 \text{ s} = 1,25 \text{ ms}$$

Table 1 – Various sensor discs

Number of segments	Max. tool speed (min ⁻¹)	Factor for actual min. Tool speed
4 *	12000	1
6	8000	1,5
8	6000	2
10	4800	2,5
12	4000	3
16	3000	4
20	2400	5
24	2000	6
32	1500	8

*recommended sensor discs

Parameters involved:

"extern. rotational speed of tools sensor", CAN parameter 4035

Default value = 0

to activate the external rotational speed of tools recording, the value must be set to "1".

"min. rotational speed of tools", CAN parameter 4078, unit min⁻¹ (rotations per minute).

Default value = 2,500

If the tool falls below the set "min. rotational speed of tools" in bypass mode, the combined fault "rotational speed of tools" is triggered.

The parameter value only corresponds to the actual rotational speed of tools when using a 4-segment sensor disk. When using a different sensor disk, the actual rotational speed of tools corresponds to the "min. rotational speed of tools" divided by "factor" from Table 1

"tool speed tolerance", CAN parameter 4076, Unit %.

Default value = 80 (%)

When the tool reaches its rated rotational speed, this rotational speed is assumed as the setpoint. If the speed differs by more than the permissible "tool speed tolerance" in bypass mode, the combined fault "rotational speed of tools" is triggered.

The parameter value 80 (%) means that the rotational tool speed must not fall below 80% of the rated rotational speed.

"Measuring time rotational tool speed", CAN parameter 4016, unit ms.

Default value = 6,000 (ms)

If the motor goes into standby after braking and detected motor stop, the rotational tool speed will continue to be recorded during this time frame. If a rotational tool speed is measured after this time, the combined fault "rotational tool speed" is triggered.

12. Operational signals

All information on the different operating states can be scanned over CAN bus. In addition, 3 light-emitting diodes are located on the device front side, which display the following operating states:

LED	Operating state
Green lights up	Device ready to operate
Red lights up	Device fault (safety-critical fault)
flashes red	Combined fault (not safety-critical fault)
yellow off	Operating state "Standby"
yellow flashes with changing frequency	Operating state "Start"
yellow lights up	Operating state "Bypass"
yellow flashes (double flashing)	Operating state "Brake"

Signal relays are available at the control terminal block X1. The following operating states are signalled:

13-14 **Operating state**

Closed during test braking from start beginning until end of braking

The function of the operating state contact can be adjusted over the system parameter "Opts Operating State Relay" (CAN Parameter 4077).

23-24 **Combined fault**

The signal contact is closed in normal operation and opens only if a combined fault has occurred.

33-34 **Device fault** - positively-driven safety relay

The signal contact is closed in normal operation and opens only if a safety-critical device fault has occurred.

43-44 **Motor standstill** - positively-driven safety relay

The signalling contact is open in case of rotating motor and closes only if a motor standstill has been securely identified.

53-54 **Ramping up** - positively-driven safety relay

The signal contact is open during start and closes when the motor has securely reached its rated speed.

13. Faults

In the device two fault groups are differentiated.

13.1 Centralised fault

Under "Centralised fault" are combined the following faults which do not affect the safety functions however, in spite of that, influence the function of the VC II S:

Centralised faults				
LED red	LED flashes yellow	fault	Reason for malfunction	Error memory code
flashes	1x	Failure L1 L2 L3	Failure of mains power supply L1, L2, L3	32
flashes	2x	Tool Speed	fault is active only when the rotational tool speed is recorded and "Rotational tool speed monitoring" (CAN parameter 4035) is switched on. The rotational tool speed deviates from the setpoint speed because of a belt break or a spinning belt (belt tension too low).	4
flashes	3x	Max. Motor Temp	The motor temperature has exceeded the value set with CAN parameter 4022 "Motor malfunction temperature". The error can only be reset after the motor has cooled down.	8
flashes	4x	Max Heatsink Tmp	The heatsink of the VC II S has exceeded the maximum permissible temperature. The error can only be reset after the cooling of the heatsink.	64
flashes	5x	Max. Opt. Start	Fault only active in startup mode "Current control with optimization"(CAN parameter 4002). The drive cannot reach its rated speed several times in succession within the specified start-up time. The number of starts is indicated in "Start-ups self-parameterization" (CAN parameter 4001). The startup time is set in "Setpoint startup time" (CAN parameter 3001). Causes: -motor rated current set too low "rated motor current" (CAN parameter 4032) - a flywheel is too large - a device defect Note! The error message is only displayed in the operating mode "Standby" i.e. not directly after the start, but only when the drive was switched off again and braked.	2
flashes	6x	3x No Standstill	Fault is only active if "Collective fault 3x no standstill" (CAN parameter 4021) has been parameterized. By default, this fault is factory-set switched on. If the motor standstill is not detected three times in a row during the monitoring time, this collective fault will be output. The monitoring time is factory-set to 10 seconds and can be adjusted via "Internal standstill monitoring time" (CAN parameter 4005). When an external standstill monitor is used, it behaves identically; the monitoring time is adjusted here with "External standstill monitoring time" (CAN parameter 4015). Causes: - a rated motor current is too low "motor current" (CAN parameter 4032) - a flywheel is too large - a device defect	16

LED red	LED flashes yellow	fault	Reason for malfunction	Error memory code
flashes	7x	Max. Start Time	The start-up exceeds the factory-set max. start-up time of 25s. Causes: - a rated motor current is too low "motor current" (CAN parameter 4032) - a wrong start-up type - a start-up current set too low - a blocked engine - a flywheel is too large - a device defect	1
flashes	8x	Max Braking Time	The braking exceeds the factory fixed max. braking time of 25s. Causes: - a rated motor current is too low "motor current" (CAN parameter 4032) - a wrong brake mode - a braking current set too low - a flywheel is too large - a device defect	128
flashes	9x	Max.Device Temp.	The thermal device image has detected an overloading of the device Causes: -start/brake frequency too high -blocked motor -flywheel is too large Note! This fault should only be reset after a cooling time of at least 15 minutes. If the fault is reset too early, an overload can be detected immediately on the next startup.	256
flashes	10x	Restart Cycles	More unbalanced mains voltage zero crossings will be detected, as specified in parameter "Restart unbalance zero crossings" (CAN parameter 4526). Factory set 10. Causes: -fluctuating frequency of the mains voltage, motor starting up poorly	512
flashes	11x	Act.Start Testbr	Start input was activated during test braking	1024

With the occurrence of one or more of these faults, the drive is switched off, the device goes into the operating mode "Centralised fault" and the contact of the signal relay "Centralised fault" is opened. The operating mode "Centralised fault" is displayed by the flashing of the red LED.

The fault source can be scanned over the CAN bus or the operating unit.

For the resetting of this fault, the interference source must be removed and 24 V applied for a short time on the input, Terminal 5 (FQ) (>15 sec).

13.2 Device fault

Under "Equipment fault" are combined the following faults which affect the safety functions and could bring the device into a safety-critical operating state:

Device faults				
LED red	LED flashes yellow	fault	Reason for malfunction	Error memory code
lights up	1x	Zero-Crossing L1	-Mains phase L1 has failed -Interruption of the connection between VC II S: 2T1 and motor -Short circuit between 1L1-2T1 -> device defect Note: If the cause of the short circuit is a suspended/bonded relay, the short circuit may possibly be due to a short shutdown of the 24VDC.	4
lights up	2x	Phase L2 Relay	- Mains phase L2 has failed - Interruption of the connection between VC II S: 4T2 and motor - Short circuit between 3L2-4T2 -> device defect Note: If the short circuit cause is a hanging/glued relay, the short circuit can be eliminated by briefly switching off the 24VDC control voltage.	524288
lights up	3x	Zero-Crossing L3	-Mains phase L3 has failed -Interruption of the connection between VC II S: 6T3 and motor -Short circuit between 5L3-6T3 -> device defect Note: If the short circuit cause is a hanging/glued relay, the short circuit can be eliminated by briefly switching off the 24VDC control voltage.	8
lights up	4x	Zero-Crossing L2	-Mains phases L2 and L3 have failed -Missing synchronizing pulse for braking current -> device defect	16
lights up	5x	Byprel Fault L1	-Bypass relay between 1L1-2T1 does not close -> device defect	1048576
lights up	6x	Byprel Fault L3	-Bypass relay between 5L3-6T3 does not close -> device defect	2097152
lights up	7x	Curr. Dir. Brake	The current direction of the braking current is wrong at the beginning of braking. -Poor voltage and frequency stability of the mains voltage. -Motor too small	512
lights up	8x	Freewheel. Fault	There is no free-wheeling current during braking -> device defect	1024
lights up	9x	Over Current	The braking current is higher than the set current for the duration of the set measuring time (depending on the operating mode: start-up: parameter 4511, bypass: parameter 4515, braking: CAN parameter 4519, standby: fixed value 300). (Depending on the operating mode: start-up: parameter 4510 (value in dA), bypass: parameter 4514 (percent of nominal device current), braking: parameter 4518 (value in dA), standby: 10% of nominal device current) -Short circuit in the motor circuit -> faulty motor or wiring -Short circuit in braking current generation -> device defect	65536
lights up	10x	Under Current	The braking current is less than the set current for the duration of the set measuring time (depending on the operating mode: start-up: parameter 4509, bypass: parameter 4513, braking: CAN parameter 4517, standby: fixed value 1000). (Depending on the operating mode: start-up: parameter 4508 (percentage of nominal motor current), bypass: parameter 4512 (percentage of nominal motor current), braking: parameter 4516 (percentage of nominal motor current), standby: 0) -Motor circuit open -Mains voltage failure -Interruption in braking power generation -> Device defect	32768
lights up	12x	Stndst.Threshold	No motor standstill detected during test braking -Test braking is started on rotating motor -Motor is moved during test braking -Device internal error -> device defect	128
lights up	13x	CurrentAutoTunin	Test braking failed, braking current less than 2A -Interruption in the motor circuit -Device internal error -> device defect	64

LED red	LED flashes yellow	fault	Reason for malfunction	Error memory code
lights up	14x	Motor Voltage	Test braking failed, Defective motor voltage detection -Interruption in the motor circuit -Device internal error -> device defect	32
lights up	15x	Diagnosis Output	Monitoring of the safety-related output relays for motor standstill (MS), run-up end (RE), and device fault (DF). -Welded/glued relay contact → device defect -Internal error in the relay control -> device defect	16384
lights up	16x	Diagnosis Input	Monitoring the safety-related inputs for start (Start), rotating speed tool (nT) and external standstill detection (ext. n0). -Short circuit between the input terminals -> wiring -Internal error in the input circuit -> device defect	8192
lights up	17x	Voltage Level	The mains voltage is lower than the specified lower limit (approx. 20% below the permissible minimum device voltage). Falling below the lower limit of the mains does not ensure a safe device function. -Mains voltage generally too low -Unstable mains voltage	2
lights up	18x	Phase Symmetry	The mains voltage has inadmissible asymmetries between L1, L2, L3. Eventually, the mains may not be capable of sufficient load.	1
lights up	19x	EEPROM Error	Error in the data stored in the EEPROM. -> Device defect Note: Eventually, the fault can be eliminated by briefly switching off the 24VDC control voltage.	262144
lights up	20x	Device Data	Initialization error. The determination of the device data (device voltage, device current) is not possible -> Device defect	131072
lights up	21x	Undef. Condition	Program execution error. The device is in an undefined operating state -> device defect Note: Eventually, the fault can be eliminated by briefly switching off the 24VDC control voltage.	2048
lights up	22x	RAMTEST Error	Internal memory error of the μ -controller -> device defect Note: Eventually, the fault can be eliminated by briefly switching off the 24VDC control voltage.	256
lights up	23x	Firing FaultL1L3	The thyristors L1 or L3 do not fire during startup. -> Device defect At the beginning of the soft start all thyristors are checked whether they are firing. If a Thyristor does not fire, the error message is displayed. During the entire startup it is also checked whether the Thyristors fire. If there are 10 misfires, the error message is also output.	4194304

With the occurrence of one or more of these faults, the drive is switched off, the device goes into the operating mode "Equipment fault" and the secure contact of the signal relay "Equipment fault" is opened. The operating mode "Equipment fault" is displayed with a permanent lighting up of the red LED.

The fault source can be scanned over the CAN bus or the operating unit.

13.3 Reset fault

In the case of an error, proceed as follows:

Centralised fault	<p>After the error has been corrected, the error message can be reset by entering "Error acknowledgment" or by pressing (> 8s) of the rotary encoder on the front of the device.</p> <p>This is also possible while "Language-German" appears on the display. After 9s, the display changes to "Collective fault acknowledgment!".</p> <p>After releasing the button, the collective faults are reset and the device is reinitialized.</p>
Device fault	<p>After the elimination of the safety-critical fault, the error message can be reset through a short switching off (5s) of the 24V control voltage. If the error cause cannot be eliminated, the error message remains present in spite of reset attempt.</p>



Warning note:

In every case the reason for malfunction must be determined and eliminated by trained personnel. Only after that may the device be put into operation again.

14. CAN-BUS

All CAN signals are isolated galvanically from device-internal voltages. The connection is implemented over RJ45 plug.

As delivered, a baud rate of 125 kBaud is adjusted.

There is an address selector switch on the front of the unit. This address selector assigns a unique node ID (address) to the VC II S in a CANOpen network. In the delivery state this is set to 0. This corresponds to a node ID of 57. By means of CAN parameters or the LCD panel, however, each address selection switch setting can be assigned an individual node ID (address).

For a trouble-free transfer of the CAN data, it is absolutely necessary that the following be considered:

- After every switchover of the address switch, a short disconnection of the 24V control voltage is necessary (reset).
- If only one CAN station is attached on a device, and the CAN plug for this subscriber is removed and reinserted, a short disconnection of the 24 V control voltage is required (reset).
- If only one CAN station is attached on a device, a plug with terminating resistor is to be inserted into the second CAN socket.

Please contact us if detailed documentation (EDS file) for the available CAN parameters of the VC II S devices is required.

15. Technical data

15.1 General specifications (12-60A-Devices)

Type designation	VC II S 480 - / VC II S 575 -				
	12	22	37	50	60
Device rated current I_e	12A	22A	37A	50A	60A
Maximum start-up / braking currents (6x I_e)	72A	132A	222A	300A	360A
Rated operating voltage U_e	200...480V / 400...575V $\pm 10\%$ 50/60Hz				
Control feed voltage U_s	24V DC $\pm 10\%$ (min. 1A)				
Motor rated power at U_e 400V IE3 motors	1,5 – 4kW	5,5 – 7,5kW	11 – 15kW	18,5 – 22kW	25 – 30kW
Motor rated power at U_e 400V IE2 motors	5.5kW	11kW	18.5kW	25kW	30kW
Switching cycles per hour with $t_{an}/t_{br}=10s$ with resp. $3x I_{rated} (device)$	30				
Utilisation category ...:AC-53b:6-6:114	12A:...	22A:...	37A:...	50A:...	60A:...
max. power dissipation - in operation with max. start frequency at $t_{an}/t_{br}=10s$ with resp. $3x I_{rated} (device)$ - in Standby	24W	40W	62W	81W	96W
	6W	6W	6W	6W	6W
$I_{\theta}(125^\circ)$ (A ² s) - Thyristors in L1, L3	720	9100	16200	51200	125000
$I_{\theta}(125^\circ)$ (A ² s) - Freewheeling Thyristors	720	4000	4000	51200	51200
Minimum motor load	40% of the device rated current				
Start function: Voltage ramp					
Start-up time	0.5 ... 20s				
Start voltage	20 ... 80%				
Start function: Current control					
Start-up time	Self-optimising (default = 9s)				
Inrush current limitation xI_e	150 ... 600% with reference to device I_{rated}				
Braking time	fixed braking time 0.25 ... 25s or self-optimised (default)				
Repeat operational readiness	200ms				
Input impedance control inputs	5kOhm				
Control voltage U_c	24VDC				
Switching capacity relay outputs	4A / 250VAC / 30VDC				
Overvoltage category / Pollution degree: Control and auxiliary circuit Main circuit	III / 2 III (TT / TN / IT - networks) / 2				

Rated surge voltage resistance U_{imp} : Control and auxiliary current circuit Main circuit	4kV 6kV				
Rated insulation voltage U_i : Control and auxiliary current circuit Main circuit	250V 600V				
max. connection cross-section inflexible/flexible: Control terminals Power terminals Length of the insulation stripping or wire end sleeve	1.5 mm ² 1.5 ...16 mm ² 18mm		1.5 mm ² 6 ... 35mm ² 15mm		
max. tightening moment: Control terminals Primary circuit	Push-in terminal Push-in terminal -		Push-in terminal 3.5Nm 26.6 ... 31lbs-in		
Drive connecting screws	-		Hexagon socket screw SW 5mm		
Weight	1.45kg	1.5kg	1.55kg	3.8kg	3.9kg

15.2 General specifications (90-140A-Devices)

Type	VersiComb II S ...- (VC II S)		
	90	110	140
Order number	2C300.48090	2C300.48110	2C300.48140
Product standard	EN60947-4-2		
Rated operating mode, device variant	Continuous operation, device variant 1 bridged control device		
Utilization category	90A:AC-53b: 6-10:110	110A:AC-53b: 6-10:134	140A:AC-53b: 6-10:170
Rated voltage U_n	200...480VAC / 400...600VAC -15% +10%		
Rated Current I_n	90A	110A	140A
Rated frequency	50Hz / 60Hz		
max. Motor rated power at 380/415V: IE2-Motor IE3-Motor	45kW 37kW	55kW 45kW	75kW 60kW
Switching cycles per hour at tan/tbr=10s witch each 3x I_{rated} (device)	30/h	25/h	20/h
max. power loss - during operation at the maximum starting frequency at tan/tbr=10s witch each 3x I_{rated} (device) - Standby	115W 6W	115W 6W	120W 6W
PI - Power semiconductors	320000A ² s	320000A ² s	336200A ² s
Minimum engine load	20% of the device's nominal power		
Start-up time	self-optimizing (default 9s) or max. 25s		
Current limitation xIe: Start-up braking	150 ... 600% 150 ... 600%		
Starting voltage	40 ... 80%		
Braking time	self-optimizing (default) or max. 25s		
Readiness to repeat	200ms		
Rated insulation voltage U_i : Control and auxiliary circuits Main circuit	250V 600V		
Rated impulse withstand voltage U_{imp} : Control and auxiliary circuits Main circuit	4kV 6kV		
IP protection class	0		
Pollution burr / Overvoltage category: Main circuit Control and auxiliary circuits	2 / III (TT / TN-Networks) 2 / II		
Rated control supply voltage U_s	24VDC \pm 10% min. 3A		
Rated actuation voltage U_c	24VDC \pm 10%		
Input resistance control inputs	5kOhm		
Switching capacity relay outputs RA1 / RA2	4A / 250VAC / 30VDC		
Emitted interference	Device class B		
Interference immunity	according to EN60947-4-2		
Installation class	3		
max. connection cross-section rigid / flexible: Control terminals Power terminals Length of the stripping or wire end ferrule	1,5mm ² 70mm ² 25mm		
max. torque: Control terminals Main circuit	Push-in terminals 13Nm / 115lbs in		
Drive connection screws	SW 6mm - Hexagon socket		
Ambient / storage temperature	0°C ... 45°C bis 1000m Height / -25°C ... 75°C		
Dimensions (WxHxD)	205 x 280 x 180mm		203 x 280 x 200mm
Weight	6300g		7700g
Special voltages (optional)			
For special devices, please note the additional sheet with the relevant information!			

15.3 EMC Information

Radiated interference	Standby/Bypass operation: DIN EN 61000-6-3 Start/Braking operation: DIN EN 60947-4-2
Installation class (according to EN 61000-4-5)	3
Characteristic criteria according to DIN EN 60947-4-2 in case of test level for CE Test.	1 or 2 (if failure, then only in secure direction)
According to characteristic criteria DIN EN 60947-4-2 in case of increased test level for "Functional safety" (SIL1) according to DIN EN 61326-3-1.	3 (if failure, then only in secure direction)
DIN EN 61000-4-2; ESD CE Test: SIL1-test:	4 kV contact / 8 kV air 6 kV contact / 8 kV air
DIN EN 61000-4-3; EMF CE Test: SIL1-test:	0.08-1GHz 10/m, 1.4-2.7GHz 3V/m 0.08-1GHz 20/m, 1.4-2GHz 10V/m, 2-2.7GHz 3V/m
DIN EN 61000-4-4; BURST CE Test: SIL1-test:	Network/Motor 2 kV, I/O signal 1kV Network/Motor 3kV, 2 kV I/O signal, CAN bus 2 kV
DIN EN 61000-4-5; SURGE CE Test: SIL1-test:	Network/Motor connections 1 kV conductor-conductor, 2 kV ground conductor 2kV conductor-conductor, 4kV ground conductor
DIN EN 61000-4-5; SURGE CE Test: SIL1-test:	I/O signal asymmetric 1kV conductor-conductor, 2kV ground conductor 2kV conductor-conductor, 4kV ground conductor
DIN EN 61000-4-5; SURGE CE Test: SIL1-test:	Screened CAN-Line 1kV ground conductor 2 kV ground conductor
DIN EN 61000-4-6; HF Field CE Test: SIL1-test:	0.15-80MHz 10V 0.15-80MHz 10V
DIN EN 61000-4-8; magnetic fields CE and SIL1-test:	30 A/m
DIN EN 61000-4-11; short interruption CE and SIL test	0% 250/300 network periods (5000 ms)
DIN EN 61000-4-11 voltage dips CE and SIL test	{ 0% 1 network period (20 ms/16. 67 ms) 40% 10/12 network periods (200 ms) 70% 25/30 network periods (500 ms)
DIN EN 61000-4-13 harmonic component CE and SIL test	Class 3

15.4 Environmental conditions

Ambient temperature	-15°C ... 45°C to 1000 m height
Storage temperature	-25°C ... 75°C
Power reduction	Greater than 45°C -2% per 1°C to max. 50°C and installation levels above 1000 m -1% per 100 m
Protection type	IP 20

15.5 Safety specifications

Functional safety according to DIN EN 61508	SIL 1
Safety of machines according to DIN EN 13849	PL c
Safety functions:	<ul style="list-style-type: none"> • Prevention of an unexpected, fault-dependent starting • Monitored, controlled braking down - Secure control activation of the protection door interlocking - Motor standstill monitoring
MTTFd	
PFH	
B10d	

15.6 Safety figures

Parameter	Value	Comments
PFH	1,8 E-07 1/h	< 2% of SIL1 (1E-05 1/h)
MTTFD	>17a	
DCavg	>90%	

15.7 Dimensions

	A	B	C	D	E*
VC II S, 12 - 37A (size 1)	103mm	230mm	138mm	86mm	220mm
VC II S, 50 - 60A (size 2)	205mm	230mm	160mm	183mm	220mm
VC II S, 90 - 110A (size 3)	205mm	280mm	180mm	180mm	267,5mm
VC II S, 140A (size 4)	205mm	280mm	200mm	180mm	267,5mm

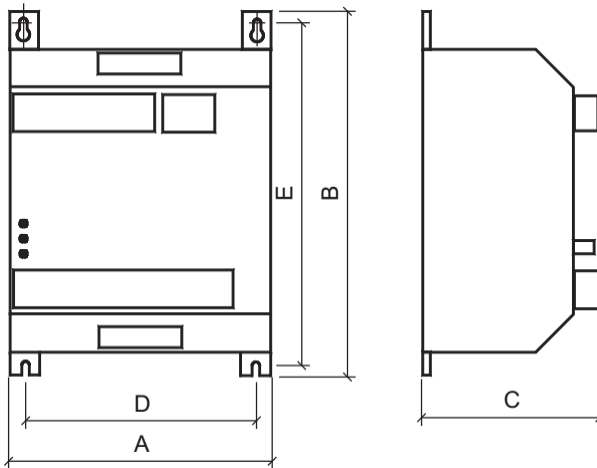

16. Dimensioning rules

16.1 Dimensioning of fuses for device protection

The pre-fuses can be dimensioned based on the following instruction:

With a fusing according to allocation type "1" to DIN EN 60947-4-2, the VC II S may be inoperative after a short-circuit. After an overload or after an output-sided short-circuit, maintenance work is possible.

The following dimensioning rules refer to the following operating conditions:

- Utilisation of asynchronous motors IE1, IE2 and IE3 (IE4 in preparation)
- Start and braking times according to datasheet
- Switching frequency not higher than as indicated in the datasheet

Fusing according to allocation type "1"

Fuses of the operating class aM are recommended as pre-fuses.

If these fuses are also used as line protection, the line cross-section is to be correspondingly coordinated!

Short-circuit protection according to EN 60947-4-2

Device rated current (Technical data)	Device type	Fuse rating with allocation type 1	Fuse type (recommendation)
12A	VC II S ...-12	16A	690V NH00
22A	VC II S ...-22	25A	690V NH00
37A	VC II S ...-37	40A	690V NH00
50A	VC II S ...-50	63A	690V NH00
60A	VC II S ...-60	80A	690V NH00
90A	VC II S ...-90	125A	690V NH1
110A	VC II S ...-110	160A	690V NH1
140A	VC II S ...-140	200A	690V NH1

Short-circuit protection according to UL 508 (Class RK5 Fuse)

Device rated current (Technical data)	Device type	Fuse rating	Fuse
12A	VC II S 480/ 575-12	20A	600V AC
22A	VC II S 480/ 575-22	40A	600V AC
37A	VC II S 480/ 575-37	50A	600V AC
50A	VC II S 480/ 575-50	60A	600V AC
60A	VC II S 480/ 575-60	80A	600V AC

Fusing according to coordination type "2"

The power semiconductors are to be protected by semiconductor protection fuses of the utilization category aR or gR. However, since these fuses do not ensure line protection, it is necessary to use additionally line protection fuses (utilization category gG).

To protect the semiconductors it is necessary to select fuses having cut-off- I^2t -values which are approx. 10-15% below the threshold- I^2t -value of the power semiconductor (see technical data). In this connection, the fuse rating of the selected fuse should not be smaller than the starting current to be expected.

Notes:

1. PETER electronic does not prescribe the use of semiconductor protection fuses. However, for some UL- or CSA-listed devices there are exceptions which are indicated in the relevant commissioning instructions.
2. On the basis of the I^2t -value of the power semiconductors, the starting time and possibly the max. starting current, the fuse supplier is able to select a suitable type. Due to the great variety of producers, sizes and types, PETER electronic does not recommend any particular fuses.
3. If the value of the fuse or the cutoff- I^2t -value is selected too small, it may happen that the semiconductor fuse reacts during the starting phase or during soft stop.

16.2 Motor protection switch

16.2.1 IEC / Europe 400 V

Motor power	Schneider Electric	EATON	Siemens
5.5kW	GV3	PKE 16-65A	3RV2021_17-22A
11kW	GV3	PKE 16-65A	3RV1031_28-40A
22kW	GV3	PKE 16-65A	3RV1041_45-63A
25kW	GV3	PKE 16-65A	3RV1041_45-63A
30kW	GV3	PKE 16-65A	3RV1041_57-75A
45kW	GV4	NZM125-160	3RV 1063
55kW	GV4	NZM125-160	3RV 1063
75kW	GV5	NZM125-160	3RV 1063

16.2.2 UL / CSA

Device Model	Max. Branch Circuit Protection Rating	Siemens	EATON
VC II S 575-12	16A	3RV2011_16-22A	PKE 16-65A
VC II S 575-12	20A	3RV2021_18-25A	-
VC II S 575-22	32A	3RV2031_22-32A	-
VC II S 575-22 VC II S 575-37 VC II S 575-50 VC II S 575-60	65A	-	PKE 16-65A
VC II S 575-37	45A	3RV2031_35-45A	-
VC II S 575-50	45A	3RV1041_42-52A	-
VC II S 575-60	73A	3RV2031_62-73A	-

17. Installation guideline

The devices are to be installed into a switchbox or switchgear cabinet according to point 7. It must be ensured that the switchbox/switchgear cabinet is capable of dissipating the occurring power loss (see techn. data).

17.1 Connection

The device is to be installed according to the attached connection diagram. For other connections please consult PETER electronic GmbH & Co. KG..

17.2 Earthing

The electrical earthing provided ensures a low impedance connection between all metallic surfaces. Apart from providing a degree of electrical safety and isolation, the earthing also has the beneficial effect that the flow of RF currents can be directed through the structure of the equipment rather than through sensitive circuits, where it could be disruptive. It is for this reason that it is vitally important to provide separate earth conductors for each part of the installation which are all connected to a common star point.

17.3 Cabling

To avoid EMI couplings into the electronics and the disturbances they involve, it must be ensured that the control cables are laid separately in separate cable ducts and as far as possible away from the power cables. If control cables need to cross power cables, they have to be laid at an angle of 90° (Figure 1).

When connecting shielded cables, make sure that the unshielded cable ends are as short as possible. The large-surface shield bonding must necessarily be located at the end of the shielding but may also be established in a suitable place - at a distance of some centimeters (Figure 2).

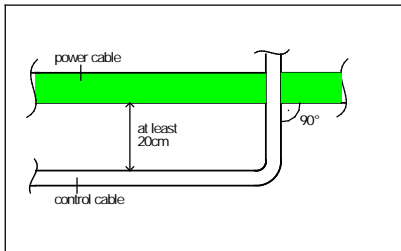

Figure 1

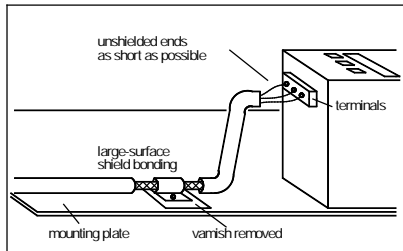

Figure 2



Caution!

The protective conductor connection to the motor must not be laid in shielded motor cables, but is to be separately laid with an appropriate cross-sectional area. The individual earthing systems, power earth, protective earth, digital earth, and analog earth conductors should be laid separately by using a suitable star-point wiring.

Note: Further connection diagrams for special circuit arrangements are available on our homepage at www.peter-electronic.com.

Note: Prior to putting the VersiComb II S into operation, the wiring is to be checked.

18. connection proposals

18.1 connection proposal: Standard wiring diagram

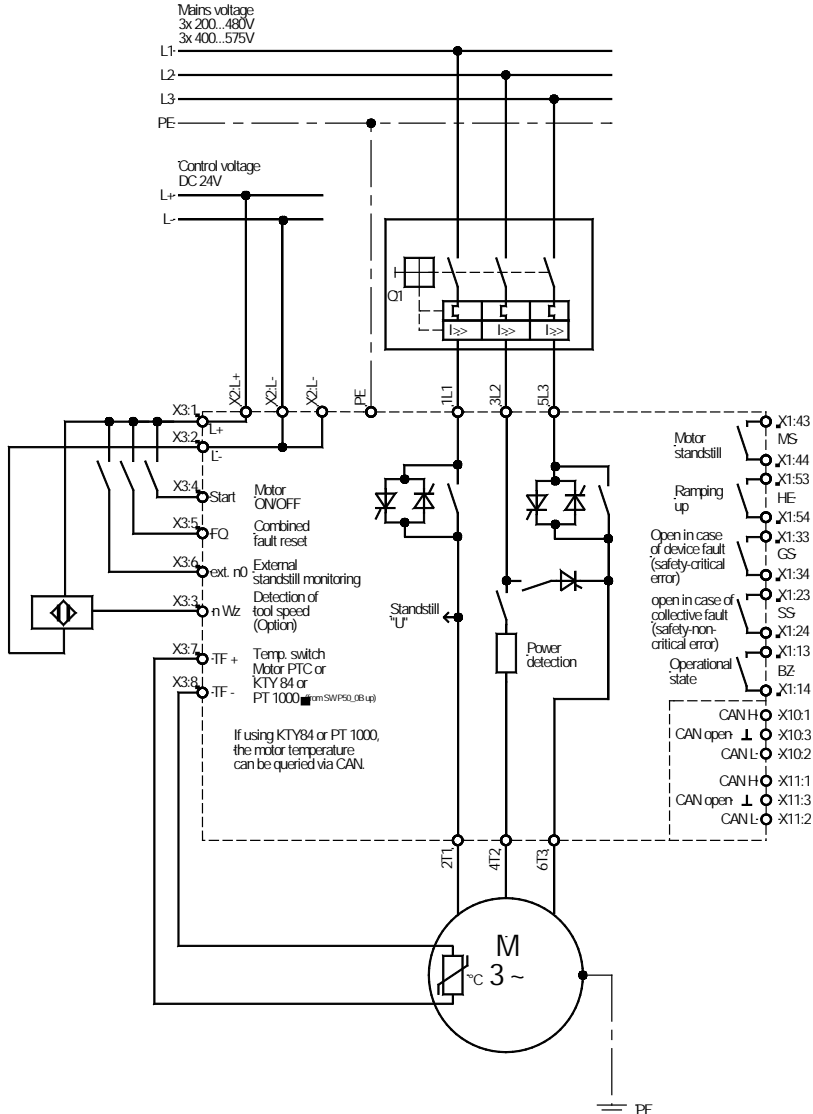

18.2 connection proposal: Reversing circuit with switch

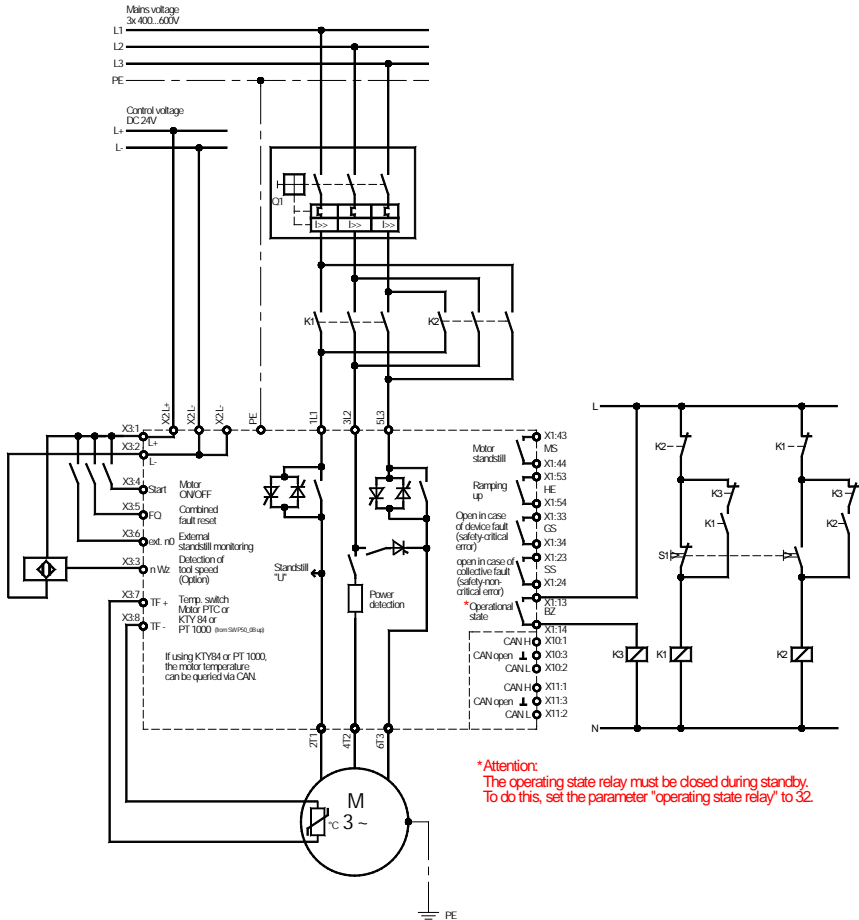

19. Timing diagram

19.1 Switch-on of the control voltage 24 V DC

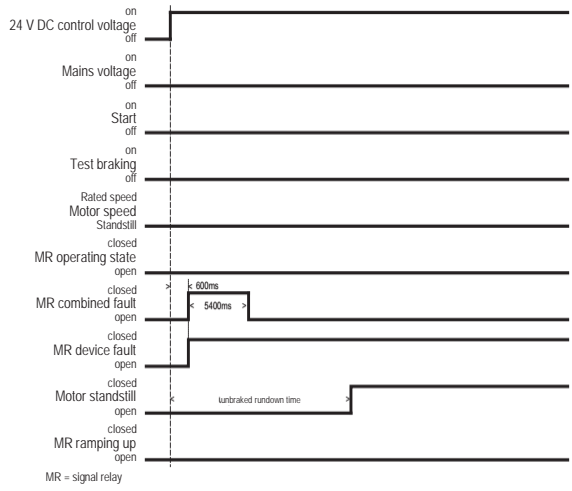

19.2 Switch-on of the 24 V DC control voltage and the mains voltage

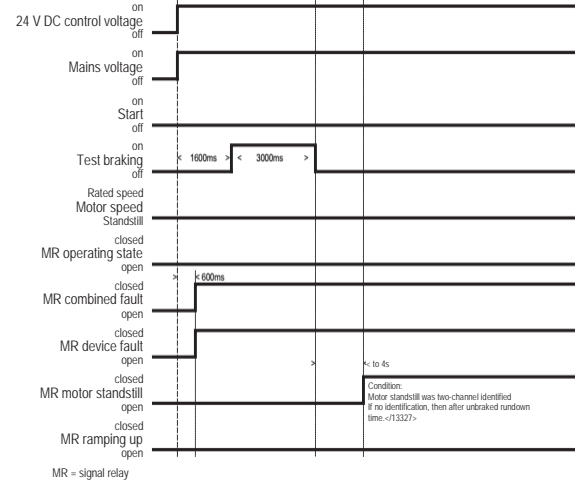

19.3 Start/Stop procedure

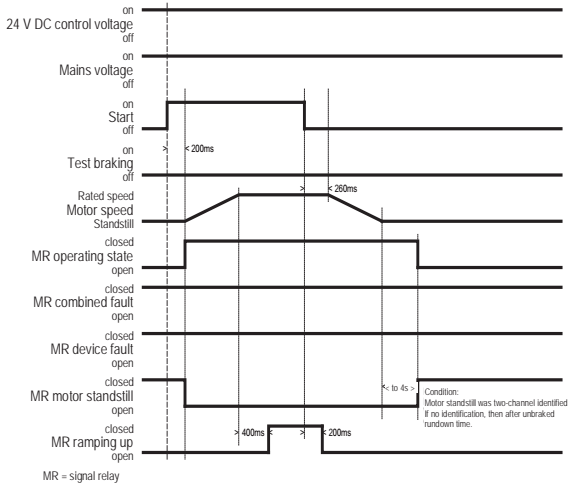

19.4 Switch-on of the voltages if motor rotates

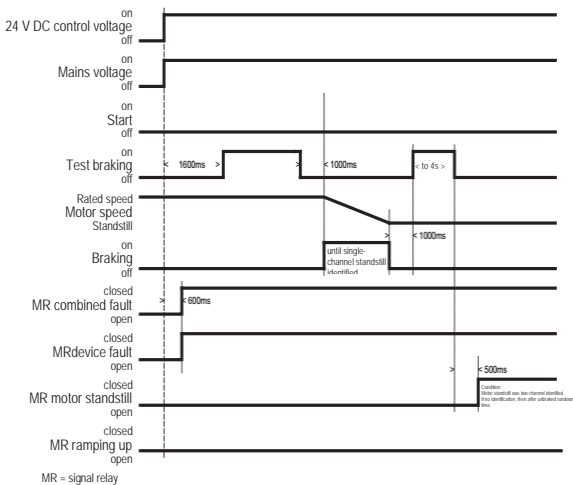

19.5 Occurrence of an device fault

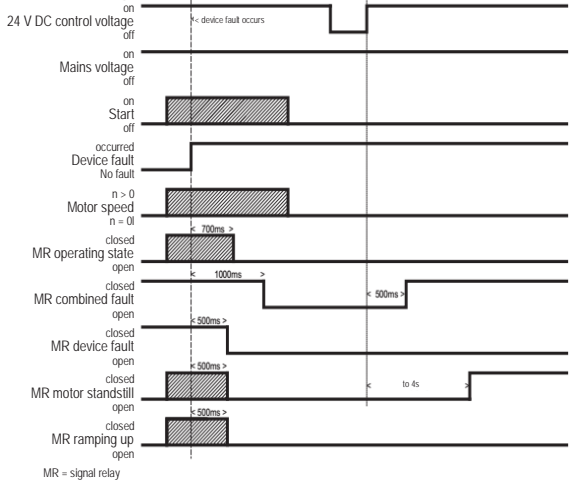

19.6 Occurrence of a Combined fault

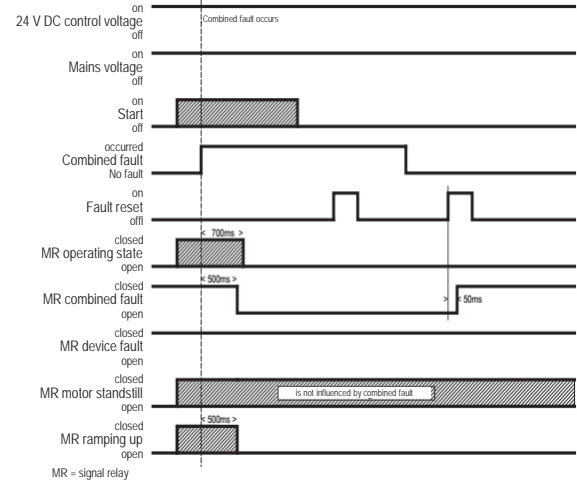



www.peter-electronic.com

