

This wiring proposal has been prepared with great care. Nevertheless, PETER electronic GmbH & Co. KG does not assume liability for damage resulting from mistakes possibly contained in it. We reserve the right to make changes due to technical improvements.

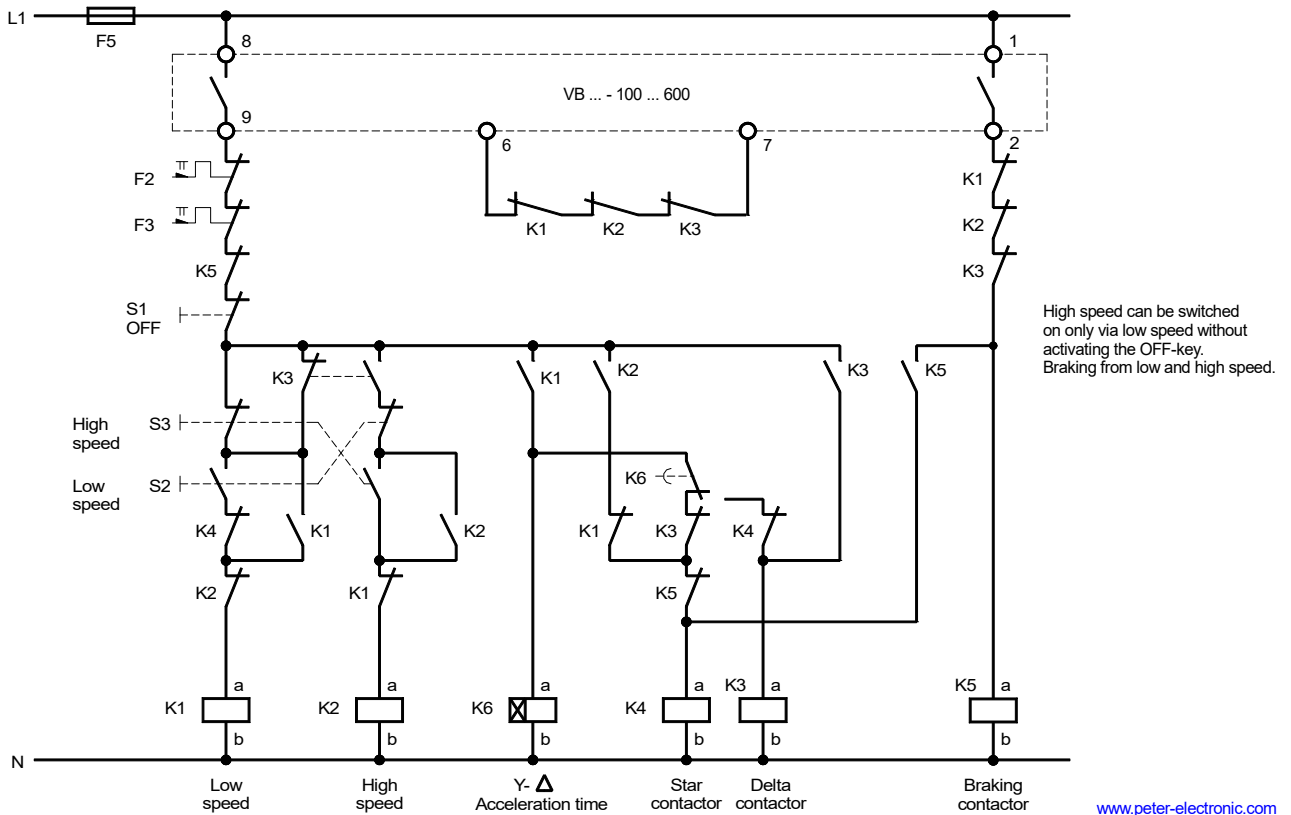

www.peter-electronic.com

PETER electronic GmbH & Co. KG, Bruckäcker 9, D-92348 Berg, Tel. (09189) 4147-0, Fax (09189) 4147-47

Electronic braking system VersiBrake [100 - 600A] with
Star-delta pole-changing contactor (Dahlander)
Star-delta start only via low speed

Nummer:
Connection diagram

Bearb.: Wein

Datum 15.07.2011

Filename: VB-100_Stern_Dreieck_Dahl_GB.skf

Geändert:

Geprüft: Ki

Blatt von