

This wiring proposal has been prepared with great care. Nevertheless, PETER electronic GmbH & Co. KG does not assume liability for damage resulting from mistakes possibly contained in it. We reserve the right to make changes due to technical improvements.

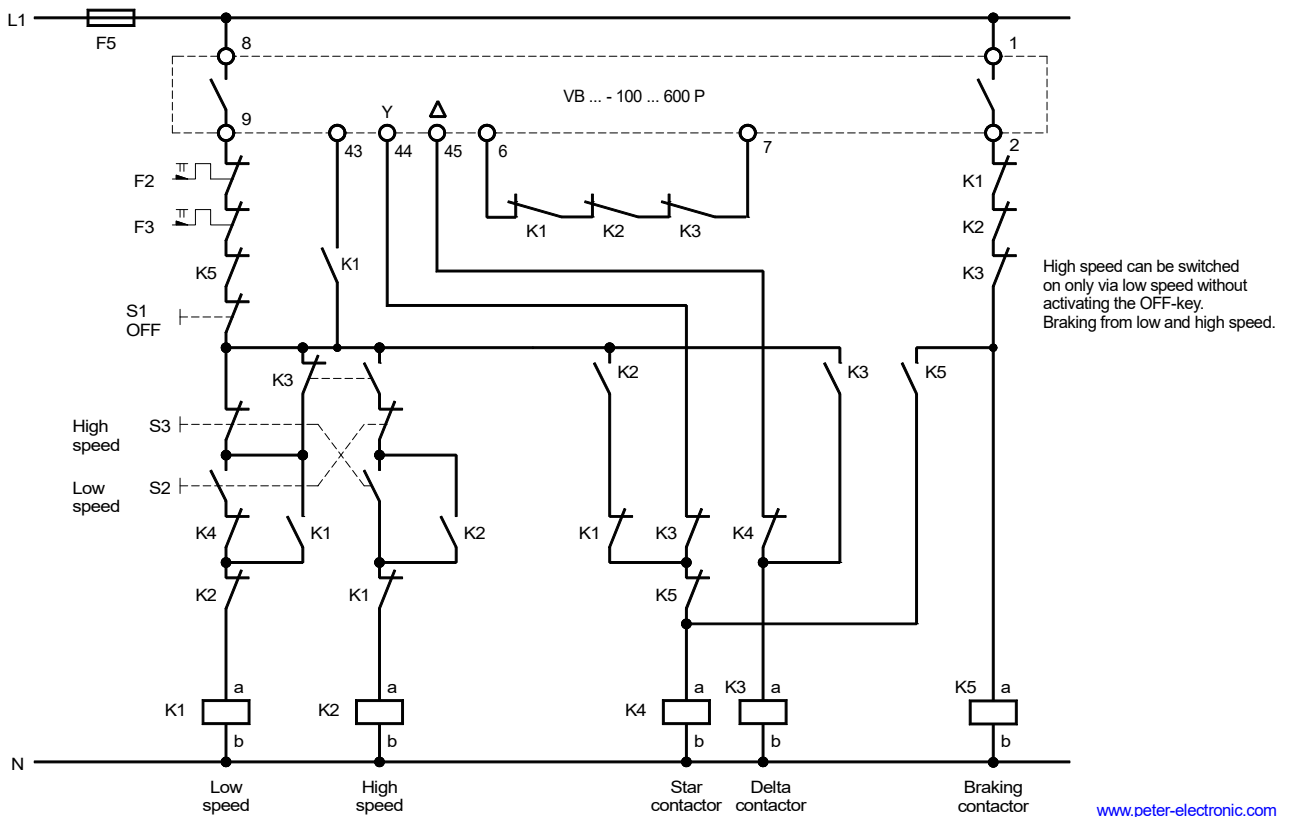

www.peter-electronic.com

PETER electronic GmbH & Co. KG, Bruckäcker 9, D-92348 Berg, Tel. (09189) 4147-0, Fax (09189) 4147-47

Electronic braking system VersiBrake [100 - 600A] option P
with Star-delta pole-changing contactor (Dahlander)
Star-delta start only via low speed

Nummer:

Connection diagram

Bearb.: Wein

Datum 02.08.2011

Filename: VB-100P_Stern_Dreieck_Dahl_GB.skf

Geändert:

Geprüft: Ki

Blatt von