

This wiring proposal has been prepared with great care. Nevertheless, PETER electronic GmbH & Co. KG does not assume liability for damage resulting from mistakes possibly contained in it. We reserve the right to make changes due to technical improvements.

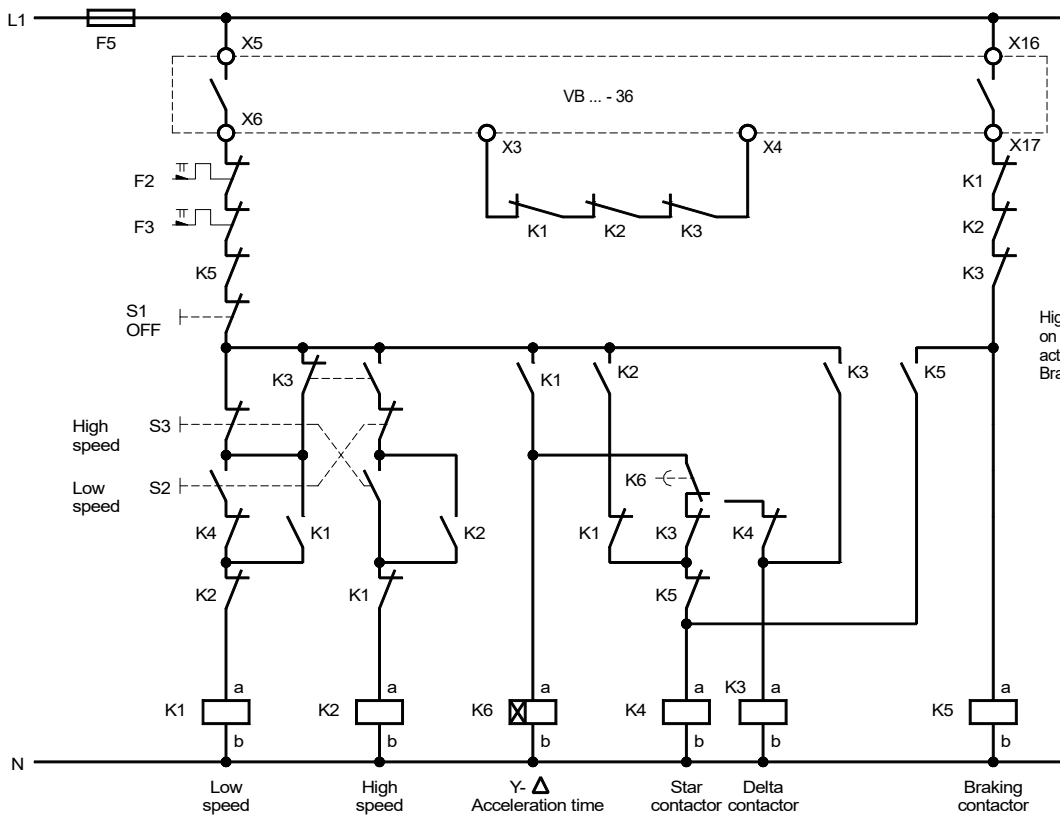

High speed can be switched on only via low speed without activating the OFF-key. Braking from low and high speed.

[www.peter-electronic.com](http://www.peter-electronic.com)

PETER electronic GmbH & Co. KG, Bruckäcker 9, D-92348 Berg, Tel. (09189) 4147-0, Fax (09189) 4147-47

Braking device VersiBrake [36A] with  
Star-delta pole-changing contactor (Dahlander)  
Star-delta start only via low speed

Nummer:  
Connection diagram

Bearb.: Wein

Datum 12.07.2011

Filename: VB-36\_Stern\_Dreieck\_Dahl\_GB.skf

Geändert:

Geprüft: Ki

Blatt von