

**Features:**

- two-phase controlled soft starter
- controlled by microcontroller
- optimized soft start
- current and torque reduction during acceleration
- easy mounting, for snap-mounting on
  - 35 mm standard rail
  - or directly mountable
- integrated bypass relay
- parameterization by means of three potentiometers
- no mains neutral conductor (N) required
- economically priced substitute for star-delta starters
- control side screw terminals
- compact design
  - 45 x 124 x 131mm (6-12A)
  - 45 x 154 x 131mm (22-32A)
- degree of protection IP20



Soft Starters  
VS II plus 400-6...32



**Functions:**

- soft acceleration and deceleration
- potential-free control input for soft acceleration and deceleration
- 3 separately adjustable parameters accel. time, start voltage, decel. time
- boost-start selectable
- potential-free relay output (closed, when motor is running)

**Options:**

The following option packages are available:

**VS II plus 480-6...32 with option package "B"**

- Wide-voltage variant with 200-480V

**Typical Applications:**

door and gate drives  
pumps, ventilators, fans  
conveying systems, packaging machines  
transport systems, assembly lines, machine applications

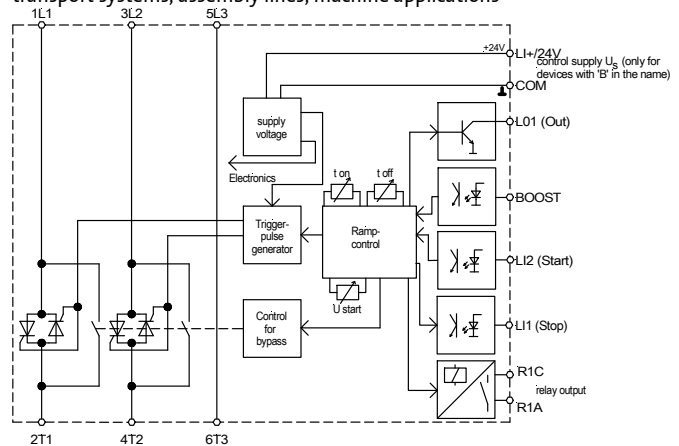

Technical specifications	VS II plus 400-6	VS II plus 400-9	VS II plus 400-12	VS II plus 400-22	VS II plus 400-32
device rated current	6A	9A	12A	22A	32A
motor rated power at 400V mains voltage	3kW	4,5kW	5,5kW	11kW	15kW
mains / motor voltage	3x 380...415VAC -15% / +10% 50/60Hz				
control voltage	24VDC ±10% (max. 28VDC) / 21,6W				
order number	26300.40006	26300.40009	26300.40012	26300.40022	26300.40032
Order number for voltage range 200-480V	26300.48006	26300.48009	26300.48012	26300.48022	26300.48032
max. power loss:					
- on standby	<3W	<3W	<3W	<3W	<3W
- in ramp-up	62W	92W	122W	223W	323W
- in bypass	1,5W	1,5W	1,5W	2,5W	2,5W
minimum motor current	20% of the device rated current				
start-up time	1 ... 10 s				
starting voltage	30 ... 80%				
run-out time	1 ... 10 s				
max. switching frequency at 3xle, 5s t <sub>on</sub> and ED=70%	20				10

cross-sectional area	AWG 20...14	
control terminals	0,5 - 1,5mm <sup>2</sup> (stripping length 10mm)	
cross-sectional area	AWG 16...10	
power terminals	1... 6mm <sup>2</sup>	
tightening torque	power terminals 1,9 ... 2,5Nm control terminals 0,5 Nm	
I <sup>2</sup> t – power semiconductor in A <sup>2</sup> s	390	9100
switching rating of relay output	2A / 250VAC / 30VDC	
overvoltage category / pollution degree	Power contacts : 3 / Auxiliary contacts (Output Relays): 2 2	
surge strength	Power contacts 4kV / Auxiliary contacts (Output Relays): 2,5kV	
insulation voltage	480VAC	
Category of use	AC53b: 6-3: 117	
protection class	IP20	
ambient/ storage temperature	-10°C... 50°C (Derating: higher 40°C - 2% per °C up to max. 50°C) -25°C... 70°C	
relative humidity	5...95% without condensation or dripping water (corresponds to EN/IEC 60 068-2-3)	
weight in kG	0,3kG	0,5kG
Dimensions W x H x D	45 x 124 x 131 mm	45 x 154 x 131 mm

**Note:**

Please pay attention and consider for the operation of IE3 motors while dimensioning of softstarters the resulting higher starting and braking currents.

For the use of IE3 motors we highly recommend to dimension and design the needed softstarters one size higher.

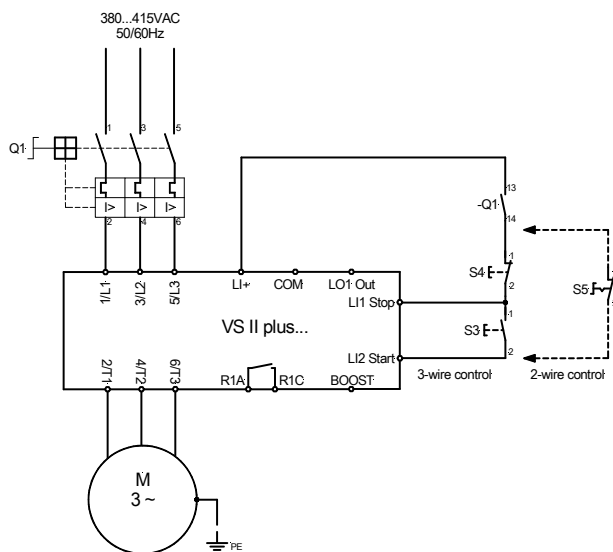
**Connection Diagram:****Standard 400V:****Voltage Range 200–480 V:**