

"W" should be connected to the motor that is the last to come to a standstill.

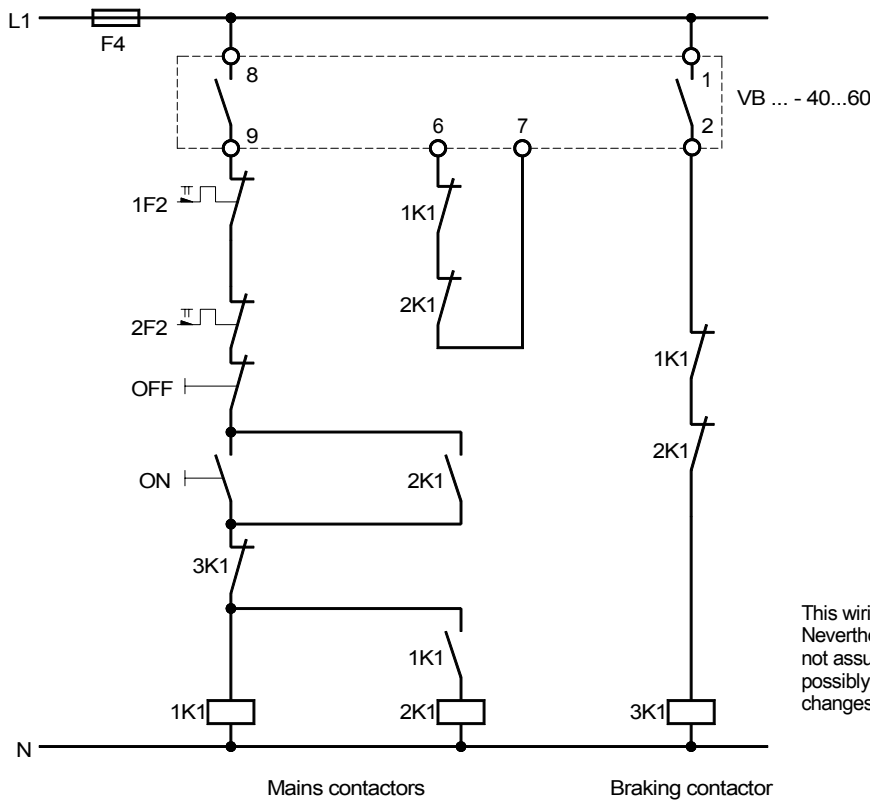

This wiring proposal has been prepared with great care. Nevertheless, PETER electronic GmbH & Co. KG does not assume liability for damage resulting from mistakes possibly contained in it. We reserve the right to make changes due to technical improvements.

PETER electronic GmbH & Co. KG, Bruckäcker 9, D-92348 Berg, Tel. (09189) 4147-0, Fax (09189) 4147-47

2 Motors parallel connected with  
VB ... - 40...60

Nummer:

Connection diagram

Bearb.: Wein

Datum 01.08.2011

Filename: VB-40\_2Mo\_direkt\_GB.skf

Geändert:

Geprüft: KI

Blatt von