

**Commissioning Instructions  
VersiStart II**

**Quality is our Drive.  
Qualität ist unser Antrieb.**

<b>Table of Contents</b>		<b>Page</b>
1.	Caution Statements	2
2.	Mechanical Installation	3
	2.1 Dimensions and Weights	3
	2.2 Physical Installation	3
3.	Electrical Installation	4
	3.1 Power Terminations	4
	3.2 Control Voltages	4
	3.3 Control Circuits	4
	3.4 Outputs	5
	3.5 Electrical Schematics	5
4.	Adjustments	6
5.	Troubleshooting	8
	5.1 LEDs	8
	5.2 Trip Codes	8
	5.3 Protections	8
	5.4 Reset	9
6.	Accessories	10
	6.1 Finger Guard Kit	10
	6.2 Remote Operator	10
	6.3 Communication Modules	10
	6.4 Pump Application Module	10
	6.5 PC Software	10
7.	Specifications	11
	7.1 General Technical Data	11
	7.2 Model Codes	12
	7.3 Current Ratings	12
	7.4 Semiconductor Fuses	13

## 1. Caution Statements

Caution Statements cannot cover every potential cause of equipment damage but can highlight common causes of damage. It is the installer's responsibility to read and understand all instructions in this manual prior to installing, operating or maintaining the soft starter, to follow good electrical practice including applying appropriate personal protective equipment and to seek advice before operating this equipment in a manner other than as described in this manual.

- Isolate the soft starter completely from the power supply before attempting any work on the starter or motor.
- Cables to the control inputs must be segregated from mains voltage and motor cabling.
- Some electronic contactor coils are not suitable for direct switching with PCB mount relays. Consult the contactor manufacturer/supplier to confirm suitability.
- Do not apply incorrect voltages to the control input terminals.
- Do not connect power factor correction capacitors to the output of VersiStart II soft starters. If static power factor correction is employed, it must be connected to the supply side of the soft starter.

The examples and diagrams in this manual are included solely for illustrative purposes. The information contained in this manual is subject to change at any time and without prior notice. In no event will responsibility or liability be accepted for direct, indirect or consequential damages resulting from the use or application of this equipment.



### **WARNING - ELECTRICAL SHOCK HAZARD**

VersiStart II soft starters contain dangerous voltages when connected to mains voltage. Only a competent electrician should carry out the electrical installation. Improper installation of the motor or the soft starter may cause equipment failure, serious injury or death. Follow this manual and local electrical safety codes.



### **GROUNDING AND BRANCH CIRCUIT PROTECTION**

It is the responsibility of the user or person installing the soft starter to provide proper grounding and branch circuit protection according to local electrical safety codes.

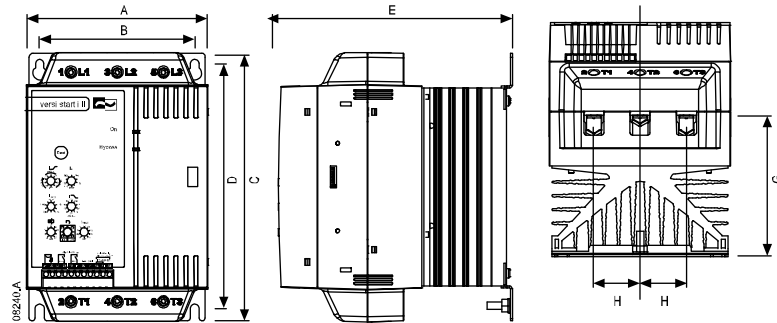


### **SHORT CIRCUIT**

VersiStart II soft starters are not short circuit proof. After severe overload or short circuit, the operation of the soft starter should be fully tested.

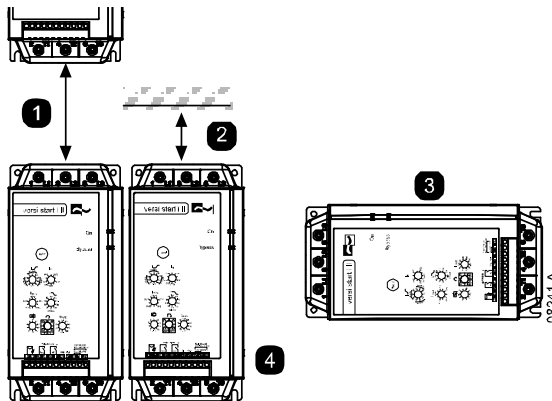
## 2. Mechanical Installation

### 2.1 Dimensions and Weights



Model	A	B	C	D	E	F	G	H	Weight
	mm (inch)	mm (inch)	mm (inch)	mm (inch)	mm (inch)	mm (inch)	mm (inch)	mm (inch)	kg (lb)
VS i II-018 VS i II-034 VS i II-042 VS i II-048 VS i II-060	98 (3.9)	82 (3.2)	203 (8.0)	188 (7.4)	165 (6.5)	55 (2.2)	90.5 (3.6)	23 (0.9)	2.4 (5.3)
VS i II-075 VS i II-085 VS i II-100	145 (5.7)	124 (4.9)	215 (8.5)	196 (7.7)	193 (7.6)	-	110.5 (4.4)	37 (1.5)	4.3 (9.5)
VS i II-140 VS i II-170 VS i II-200	202 (8.05)	160 (6.3)	240 (9.5)	204 (8.0)	214 (8.4)	-	114.5 (4.5)	51 (2.0)	6.8 (15.0)

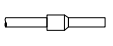
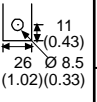


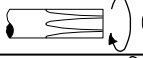

### 2.2 Physical Installation



1	VS i II-018 ~ VS i II-100: Allow 100 mm (3.9 inches) between soft starters. VS i II-140 ~ VS i II-200: Allow 200 mm (7.9 inches) between soft starters.
2	VS i II-018 ~ VS i II-100: Allow 50 mm (2.0 inches) between the soft starter and solid surfaces. VS i II-140 ~ VS i II-200: Allow 200 mm (7.9 inches) between the soft starter and solid surfaces.
3	The soft starter may be mounted on its side. Derate the soft starter's rated current by 15%.
4	Soft starters may be mounted side by side with no clearance.

### 3. Electrical Installation

#### 3.1 Power Terminations

	L1/1, L2/3, L3/5, T1/2, T2/4, T3/6 mm <sup>2</sup> (AWG)			A1, A2, A3, 01, 02, B4, B5, 13, 14, 23, 24 mm <sup>2</sup> (AWG)	
	018 ~ 060	075 ~ 100	140 ~ 200	018 ~ 200	
	10 - 35 (8 - 2)	25 - 50 (4 - 1/0)	N.A.		0.14 - 1.5 (26 - 16)
	10 - 35 (8 - 2)	25 - 50 (4 - 1/0)	N.A.		0.14 - 1.5 (26 - 16)
	Torx (T20) 3 Nm 2.2 ft-lb		N.A.	N.A.	
	7 mm 3 Nm 2.2 ft-lb		N.A.	3.5 mm 0.5 Nm max 4.4 in-lb max	

08256.A

#### 3.2 Control Voltages

VersiStart II soft starters can be supplied in either of two control voltage configurations:

VS i II-xxx-xxx-C1 .... 110-240 VAC (+ 10% / - 15%) or 380-440 VAC (+ 10% / - 15%)

VS i II-xxx-xxx-C2 .... 24 VAC/VDC (± 20%)



**WARNING**

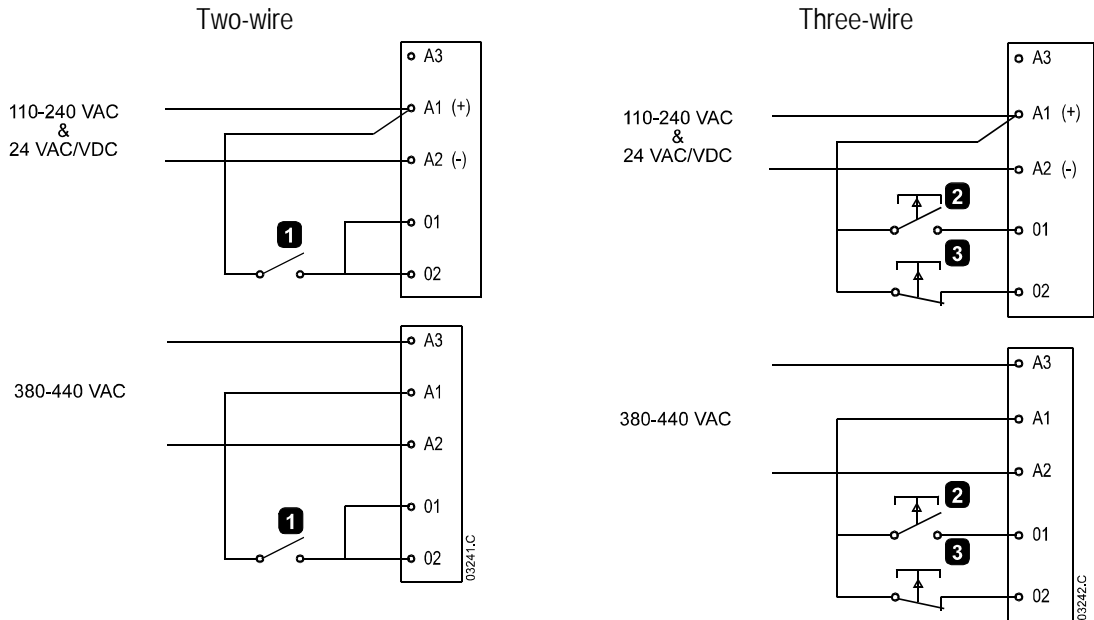
Always apply control voltage before (or with) mains voltage.



**CAUTION**

With 24 VAC/VDC use contacts rated for low voltage and low current (gold flash or similar).

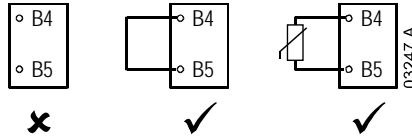
#### 3.3 Control Circuits



1	Start/stop. To reset a trip, close then open 02.
2	Start.
3	Stop. To reset a trip, close then open 02.

### 3.3.1 Motor Thermistor

Motor thermistors can be connected directly to the VersiStart II terminals B4, B5. If motor thermistors are not used, there must be a link between B4, B5 (the VersiStart II is supplied with a link fitted).



#### WARNING

Isolate the soft starter completely from the power supply before attempting any work on the starter or motor. Control terminals may be at phase voltage potential.

## 3.4 Outputs

### 3.4.1 Main Contactor Output

The Main Contactor output (terminals 13, 14) closes as soon as the soft starter receives a start command and remains closed while the soft starter is controlling the motor (until the motor starts a coast to stop, or until the end of a soft stop). The Main Contactor output will also open if the soft starter trips.

The Main Contactor output can be used to directly control a main contactor coil.

### 3.4.2 Programmable Output

The programmable output relay (terminals 23, 24) can be used to signal either trip or run status. This relay is normally open.

Trip:

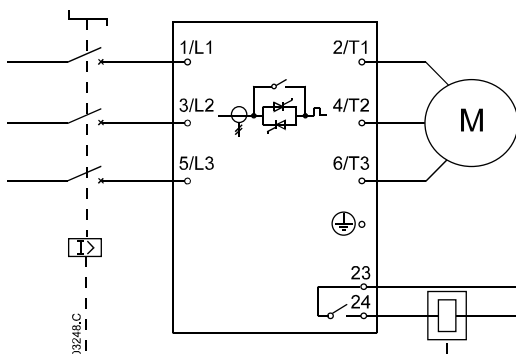
The relay closes when the VersiStart II trips. The relay can be used to operate the shunt-trip mechanism of an upstream circuit breaker (in order to isolate the motor branch circuit), or to signal the trip to an automation system or externally. The relay will open when the trip is reset.

Run:

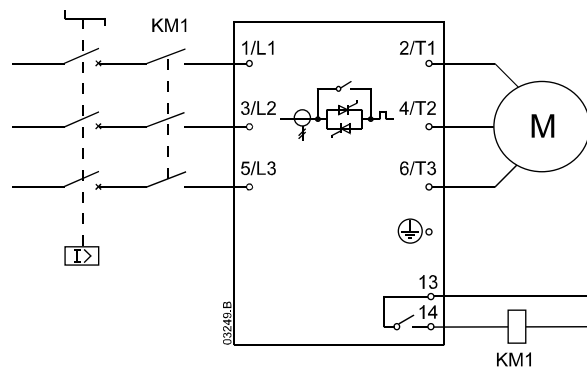
The relay operates when the soft start is complete, the bypass relays are closed and full voltage is being applied to the motor. The relay can be used to operate a contactor for power factor correction capacitors, or to signal soft starter run status to an automation system.

## 3.5 Electrical Schematics

*Figure 1: Soft starter installed with a system protection circuit breaker complete with a shunt trip device*

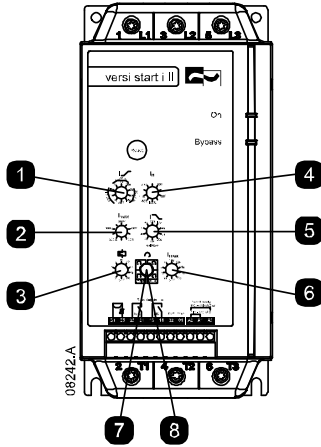


*Figure 2: Soft starter installed with a system protection circuit breaker and main contactor*



M	Motor (three phase)
KM1	Main contactor
13, 14	Main contactor output
23, 24	Programmable output (set to Trip)

### 4. Adjustments



<b>1</b>	Current Ramp
<b>2</b>	Current Limit
<b>3</b>	Motor Trip Class
<b>4</b>	Motor FLC
<b>5</b>	Soft Stop Time
<b>6</b>	Excess Start Time
<b>7</b>	Auxiliary Relay Function
<b>8</b>	Phase Sequence Protection

#### 1 Current Ramp

Select the initial start current (A) and ramp time (B). Current ramp starting extends the time soft starter takes to reach the current limit and is suitable for generator set supplies, loads requiring an extended start time or applications with extreme load variation between starts. The ramp time does not control the time the motor will take to reach full speed.

#### 2 Current Limit

Select the current limit (C). The current limit is the maximum level of current the soft starter will deliver to the motor during the soft start.

#### 3 Motor Trip Class

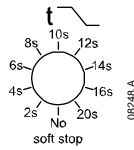
Select the trip class for motor overload protection. The trip class reflects the maximum time (in seconds) that the motor can run at locked rotor current. The Motor Trip Class setting assumes a locked rotor current of 600%.

Setting the motor trip class to "Off" disables motor overload protection.

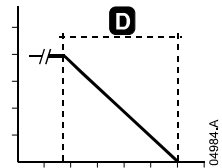
#### 4 Motor Full Load Current

Configure the soft starter to match the motor's full load current (FLC). Configure according to the motor's nameplate current. Divide the motor's FLC by the soft starter's maximum current rating (on the soft starter's nameplate label).

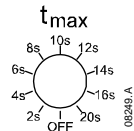
**5** Soft Stop Time



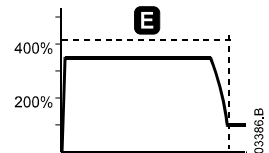
Select the soft stop ramp time (D).  
Soft stop extends the time soft starter takes to reduce voltage to zero.  
The ramp time does not control the time the motor will take to stop completely.



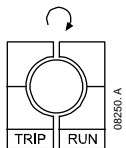
**6** Excess Start Time



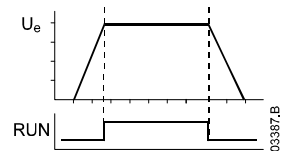
Configure the soft starter's excess start time protection.  
Select a time slightly longer than the motor requires for a normal healthy start. The soft starter will trip if the start does not complete within the selected time (E).



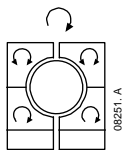
**7** Auxiliary Relay Function



Select the function of the soft starter's programmable output (terminals 23, 24).  
When set to "Run", the relay will operate when the soft start is complete. When set to "Trip", the relay will operate when the soft starter trips.



**8** Phase Rotation Protection



Configure the soft starter's phase sequence protection.  
Select the allowable phase sequences. A setting of "Fwd" allows forward sequence (positive rotation) only and a setting of "Any" defeats the protection.

		FWD	ANY
L1	soft starter	✓	✓
L2	soft starter	✓	✓
L3	soft starter	✓	✓
L1	soft starter	✗	✓
L2	soft starter	✗	✓
L3	soft starter	✗	✓

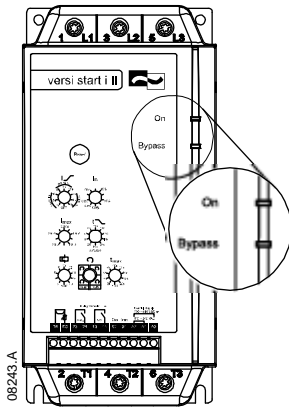


**NOTE**

Auxiliary relay function and phase rotation are configured using a shared switch. Set the auxiliary relay function as required, then set phase rotation protection.











## 5. Troubleshooting

### 5.1 LEDs



LED Status	On	Bypass
Off	No control power	Motor not running
On	Ready	Motor running at full speed
Flash	Starter tripped	Motor starting or stopping

### 5.2 Trip Codes

On LED	Description
 x 1	Power Circuit: Check mains supply (L1, L2, L3), motor circuit (T1, T2, T3), soft starter SCRs and bypass relays.
 x 2	Excess Start Time: Check load, increase Current Limit or adjust Excess Start Time setting.
 x 3	Motor Overload: Allow motor to cool, reset soft starter and restart. The soft starter cannot be reset until the motor has cooled.
 x 4	Motor Thermistor: Check motor ventilation and thermistor connection B4, B5. Allow motor to cool.
 x 5	Phase Imbalance: Check for mains supply or line current imbalance (L1, L2, L3).
 x 6	Supply Frequency: Check mains voltage is available and supply frequency is in range.
 x 7	Phase Rotation: Check for correct phase rotation.
 x 8	Network Communication Failure (between interface and network): Check network connections, settings and configuration.
 x 9	Starter Communication Failure (between starter and interface): Remove and refit accessory interface.
 x 10	Bypass Overload: Starter rating may be too low for the application.

### 5.3 Protections

The VersiStart II includes the following types of protection for the motor and starter:

#### 5.3.1 Excess Start Time Protection

The VersiStart II will trip on excess start time if the motor does not successfully start within the time selected in the Excess Start Time setting. This may indicate that the load has stalled.

If the soft starter frequently trips on excess start time:

- check that the Current Limit setting is high enough for the application
- check that the Excess Start Time setting is long enough for the application
- check that the load has not stalled or increased since the soft starter was installed

#### 5.3.2 Motor Overload Protection

The VersiStart II will trip on motor overload if it calculates that the motor has been running above its operating range for longer than the time selected in the Motor Trip Class setting. Motor Trip Class should be set to match the motor's locked rotor time. If this information is not available from the motor datasheet, use the default setting (Motor Trip Class = 10). Using a higher setting can damage the motor.

**NOTE**

Motor overload protection does not protect the soft starter, and does not protect the motor from short circuit.

**5.3.3 Phase Imbalance Protection**

The VersiStart II will trip on phase imbalance if the highest and lowest currents on the three phases vary by an average of 30% for more than 3 seconds. Phase imbalance protection is not adjustable, and is only active when the average motor current is 50% or more of the programmed motor FLC.

If the soft starter frequently trips on phase imbalance:

- check that there is no imbalance on the mains voltage (on the input side of the soft starter)
- insulation test the motor
- move all input cables over one position (move L1 cable to L2, move L2 cable to L3, move L3 cable to L1) to rule out a cabling fault

**5.3.4 Supply Frequency Protection**

The soft starter will trip on supply frequency if the frequency rises above 72 Hz or falls below 40 Hz for more than five seconds while the soft starter is running. These trip points are not adjustable.

In pre-start, starting and stopping modes the high and low frequency limits both apply with no time delay.

A supply frequency trip will also occur if:

- all three input phases are lost while the soft starter is running
- all three input phases fall below 120 VAC at start or while the soft starter is running
- the line contactor opens while running

**5.3.5 Bypass Overload Protection**

Bypass overload protection protects the soft starter from severe operating overloads while running. The protection is not adjustable and has two components:

- The soft starter will trip if it detects overcurrent at 600% of the programmed motor full load current.
- The soft starter models the temperature of the internal bypass relays and will trip if the temperature exceeds the safe operating level.

If the trip occurs frequently, this indicates that the soft starter has not been selected correctly for the application.

**5.4 Reset**

Trips can be cleared by pressing the Reset button on the soft starter, sending a Reset command from the serial communications network, or by switching the control inputs.

To clear a trip via the control inputs, the soft starter requires a closed to open transition on the stop input (O2).

- In three wire control, use the external stop pushbutton to momentarily open the stop input (open A1-O2).
- In two wire control, if the soft starter tripped with a start signal present, remove the start signal (open A1 to O1, O2).
- In two wire control, if the VersiStart II tripped with no start signal present (eg VersiStart II motor thermistor trip), apply then remove the start signal (close then reopen A1 to O1, O2).

The Reset button is located on the front of the unit, above the adjustment switches.

The soft starter will trip again immediately if the cause of the trip still exists.

## 6. Accessories

### 6.1 Finger Guard Kit

Order Code: 995-03503-00

Finger guards may be specified for personnel safety and can be used on VersiStart II soft starter models 075~110. Finger guards fit over the soft starter terminals to prevent accidental contact with live terminals. Finger guards provide IP20 protection when used with cable of diameter 22 mm or greater.

### 6.2 Remote Operator

Order Code: 29000.25901

The Remote Operator can control and monitor the soft starter's performance. Functionality includes:

- Operational control (Start, Stop, Reset, Quick Stop)
- Starter status monitoring (Ready, Starting, Running, Stopping, Tripped)
- Performance monitoring (motor current, motor temperature)
- Trip code display
- 4-20 mA analog output (Motor Current)

### 6.3 Communication Modules

VersiStart II soft starters support network communication using the Profibus, DeviceNet and Modbus RTU protocols.

### 6.4 Pump Application Module

Order Code: 29000.25906

The Pump Application Module expands the soft starter's input and output functionality for applications where greater control and feedback are required.

Refer to the Pump Application Interface Instructions for further details.

### 6.5 PC Software

WinMaster is a purpose-designed software suite for control and monitoring of up to 99 soft starters.

- Operational control (Start, Stop, Reset, Quick Stop)
- Starter status monitoring (Ready, Starting, Running, Stopping, Tripped)
- Performance monitoring (motor current, motor temperature)

To use WinMaster with the VersiStart II, the soft starter must be fitted with a Modbus Interface (29000.25904) or a Remote Operator (29000.25901).

Refer to the WinMaster User Manual for further details.

---

## 7. Specifications

### 7.1 General Technical Data

#### Mains Supply

Mains voltage (L1, L2, L3)

VS i II 440-xxx ..... 3 x 200 VAC ~ 440 VAC (+ 10% / - 15%)

VS i II 575-xxx ..... 3 x 200 VAC ~ 575 VAC (+ 10% / - 15%)

Mains frequency (at start) ..... 45 Hz to 66 Hz

Rated insulation voltage ..... 600 VAC

Form designation ..... Bypassed semiconductor motor starter form 1

#### Control Voltage (A1, A2, A3)

VS i II xxx-xxx-C1 ..... 110-240 VAC (+ 10% / - 15%)  
or 380-440 VAC (+ 10% / - 15%)

VS i II xxx-xxx-C2 ..... 24 VAC/VDC ( $\pm$  20%)

Current consumption (during run) ..... < 100 mA

Current consumption (inrush)

VS i II xxx-xxx-C1 ..... 10 A

VS i II xxx-xxx-C2 ..... 2 A

#### Inputs

Start (terminal 01) ..... Normally open  
150 k $\Omega$  @ 300 VAC and 5.6 k $\Omega$  @ 24 VAC/VDC

Stop (terminal 02) ..... Normally closed  
150 k $\Omega$  @ 300 VAC and 5.6 k $\Omega$  @ 24 VAC/VDC

#### Outputs

Main contactor (terminals 13, 14) ..... Normally open  
6 A, 30 VDC resistive / 2 A, 400 VAC, AC11

Programmable relay (terminals 23, 24) ..... Normally open  
6 A, 30 VDC resistive / 2 A, 400 VAC, AC11

#### Environmental

Degree of protection VS i II-018 to VS i II-100 ..... IP20

Degree of protection VS i II-140 to VS i II-200 ..... IP00

Operating temperature ..... - 10 °C to + 60 °C

Storage temperature ..... -25 °C to + 60 °C (to +70 °C for less than 24 hours)

Humidity ..... 5% to 95% Relative Humidity

Pollution degree ..... Pollution Degree 3

Vibration ..... IEC 60068 Test Fc Sinusoidal  
4 Hz to 13.2 Hz:  $\pm$  1 mm displacement  
13.2 Hz to 200 Hz:  $\pm$  0.7 g

#### EMC Emission

Equipment class (EMC) ..... Class A<sup>1</sup>

Conducted radio frequency emission ..... 0.15 MHz to 0.5 MHz: < 90 dB ( $\mu$ V)  
0.5 MHz to 5 MHz: < 76 dB ( $\mu$ V)  
5 MHz to 30 MHz: 80-60 dB ( $\mu$ V)

Radiated radio frequency emission ..... 30 MHz to 230 MHz: < 30 dB ( $\mu$ V/m)  
230 MHz to 1000 MHz: < 37 dB ( $\mu$ V/m)

<sup>1</sup> This product has been designed as Class A equipment. Use of this product in domestic environments may cause radio interference, in which case the user may be required to employ additional mitigation methods.

#### EMC Immunity

Electrostatic discharge ..... 4 kV contact discharge, 8 kV air discharge

Radio frequency electromagnetic field ..... 0.15 MHz to 1000 MHz: 140 dB ( $\mu$ V)

Rated impulse withstand voltage (Fast transients 5/50 ns) ..... 2 kV line to earth, 1 kV line to line

Voltage dip and short time interruption ..... 100 ms (at 40% nominal voltage)  
 Harmonics and distortion ..... IEC61000-2-4 (Class 3), EN/IEC61800-3

### Short Circuit

Rated short-circuit current VS i II-018 to VS i II-075 ..... 5 kA  
 Rated short-circuit current VS i II-085 to VS i II-200 ..... 10 kA

### Heat Dissipation

During Start ..... 3 watts / ampere  
 During Run ..... 10 watts typical

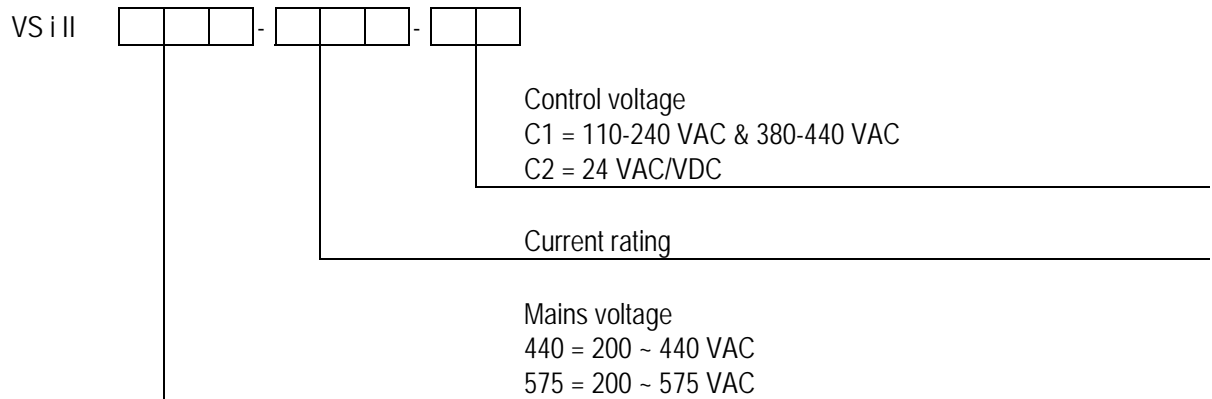
### Approvals

C✓ ..... IEC 60947-4-2  
 UL / C-UL ..... UL 508  
 CE ..... IEC 60947-4-2  
 CCC ..... GB 14048.6  
 Lloyds ..... IEC 60947-4-2

### Operational Life

VS i II-018-100 ..... 1,000,000 operations  
 VS i II-140-200 ..... 30,000 operations

## 7.2 Model Codes



## 7.3 Current Ratings

	AC53b 4-6:354 < 1000 metres		AC53b 4-20:340 < 1000 metres	
	40 °C	50 °C	40 °C	50 °C
VS i II-018	18 A	17 A	17 A	15 A
VS i II-034	34 A	32 A	30 A	28 A
VS i II-042	42 A	40 A	36 A	33 A
VS i II-048	48 A	44 A	40 A	36 A
VS i II-060	60 A	55 A	49 A	45 A
	AC53b 4-6:594 < 1000 metres		AC53b 4-20 580 < 1000 metres	
	40 °C	50 °C	40 °C	50 °C
VS i II-075	75 A	68 A	65 A	59 A
VS i II-085	85 A	78 A	73 A	67 A
VS i II-100	100 A	100 A	96 A	87 A
VS i II-140	140 A	133 A	120 A	110 A
VS i II-170	170 A	157 A	142 A	130 A
VS i II-200	200 A	186 A	165 A	152 A

#### 7.4 Semiconductor Fuses

Semiconductor fuses can be used with VersiStart II soft starters to reduce the potential for damage to SCRs from transient overload currents and for Type 2 coordination. VersiStart II soft starters have been tested to achieve Type 2 coordination with semiconductor fuses. Suitable Bussman and Ferraz semiconductor fuses are detailed below.

VS i II Model	SCR I <sup>2</sup> T (A <sup>2</sup> S)	Ferraz Fuse European/IEC Style (North American Style)	Bussmann Fuse Square Body (170M)	Bussmann Fuse British Style (BS88)
018	1150	6.6URD30xxxA0063 (A070URD30xxx0063)	170M-1314	63 FE
034	8000	6.6URD30xxxA0125 (A070URD30xxx0125)	170M-1317	160 FEE
042	10500	6.6URD30xxxA0160 (A070URD30xxx0160)	170M-1318	160 FEE
048	15000	6.6URD30xxxA0160 (A070URD30xxx0160)	170M-1318	180 FM
060	18000	6.6URD30xxxA0160 (A070URD30xxx0160)	170M-1319	180 FM
075	51200	6.6URD30xxxA0250 (A070URD30xxx0250)	170M-1321	250 FM
085	80000	6.6URD30xxxA0315 (A070URD30xxx0315)	170M-1321	250 FM
100	97000	6.6URD30xxxA0315 (A070URD30xxx0315)	170M-1321	250 FM
140	168000	6.6URD31xxxA0450 (A070URD31xxx0450)	170M-1322	500 FMM
170	245000	6.6URD31xxxA0450 (A070URD31xxx0450)	170M-3022	500 FMM
200	320000	6.6URD31xxxA0450 (A070URD31xxx0450)	170M-3022	500 FMM

xxx = Blade Type. Contact Ferraz for options.