

Softstarter  
VS ... - 17...45  
Assembly- and Commissioning Instructions

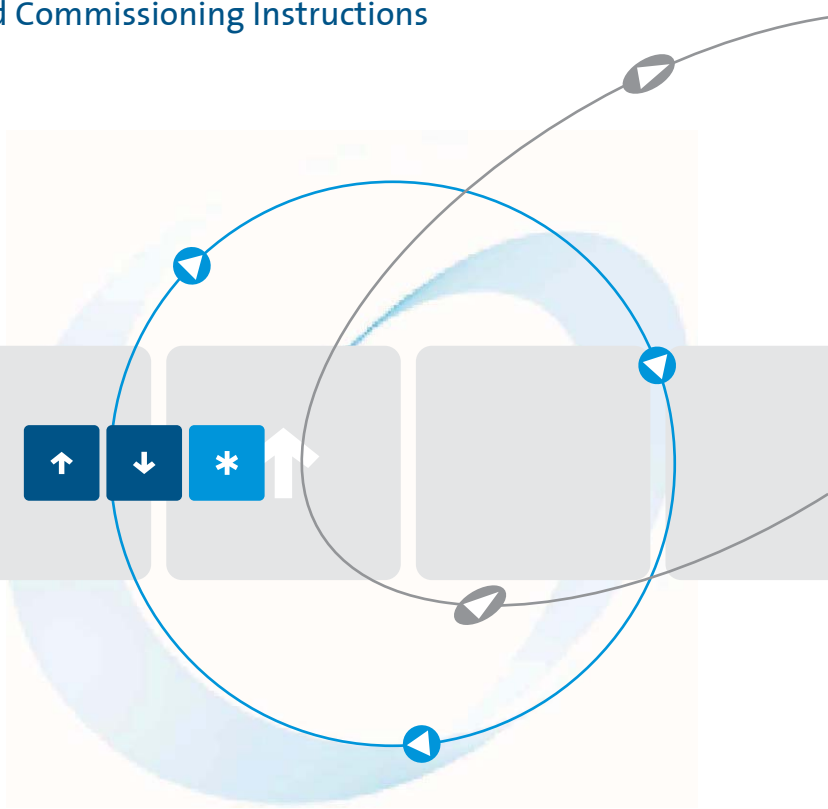

as per 10/11 15700.10005

<b>Table of Contents</b>	<b>Page</b>
1. Safety notes	3
2. Conformity	3
3. General description	4
4. Usage to the intended purpose	4
5. EC Declaration of Conformity	5
6. Block diagram	6
7. Commissioning	7
7.1 Mounting instructions	7
7.2 Connection	9
7.3 Parameter settings	10
8. LED indicators	12
8.1 Option „M“	12
9. Fault	12
9.1 Fault description	13
9.2 Fault remedy	13
9.3 Resetting of faults	14
10. Technical data (standard)*	15
10.1 Environmental conditions	16
11. Dimensioning rules	16
11.1 Dimensioning of fuses for device protection	16
11.2 Determining the permissible starting frequency	18
12. Special units	20
12.1 Devices with rated voltage of 230V or 480V	20
12.2 Devices featuring a wide-voltage-range power section	20
12.3 Devices featuring special voltage $\geq 500V$	21
12.4 Devices with motor-PTC input	21
13. Installation guideline	22
13.1 Connection	22
13.1.1 Earthing	22
13.1.2 Cabling	22
13.2 General connection diagram	23
13.3 Typical connections	24
13.4 Motor/Soft start in delta connection (only units with option „M“)	25
13.5 Wide-voltage-range connection	26

---

13.5.1 Devices with control supply voltage 24VDC	26
13.5.2 Devices with control supply voltage 230VAC	26
14. Dimensions	27
15. Special units	27

These commissioning instructions were prepared with great care. Nevertheless, PETER electronic GmbH & Co. KG does not assume liability for damage resulting from mistakes possibly contained in this manual. Technical changes that serve to improve the product are subject to change without notice.

### Notes and symbols used in these instructions

**Note:** Notes explain the advantages of certain adjustments or settings and help you to make use of the device in the best possible way.



**Warning notices: Read them carefully and follow them strictly!**

Warning notices are indicated in order to protect you against danger or to help you to prevent the device from being damaged.



**Caution: Danger to life through electric shock!**

When you see this sign, always make sure that the device is de-energized and secured against unintentional energizing.

---

## 1. Safety notes



The described devices are electrical equipment for use in industrial electrical power installations. An impermissible removal of the covers during operation can cause serious damage to your health, since these devices contain live parts with high voltages.

Adjustment work may only be performed by trained staff observing the safety regulations. Assembly and mounting work may only be carried out with the equipment deenergized.

Make sure that all drive components are properly earthed.

Please read these commissioning instructions carefully before putting the device into operation.

Besides, the user must ensure that the devices and associated components are fitted and connected in accordance with the applicable local, legal and technical regulations. The VDE-regulations VDE 0100, VDE 0110 (EN 60664), VDE 0160 (EN 50178) , VDE 0113 (EN 60204, EN 61310), VDE 0660 (EN 50274) plus the appropriate regulations of the TÜV (Technical Control Association) and the trade associations apply in Germany.

The user must ensure that the drive turns into a safe operating state following a device failure, in the event of maloperation, or if the control unit has failed etc..

**Caution:** Even if the motor is at rest, it is **not** physically separated from the mains.

## 2. Conformity

In industrial linguistic usage the drive controllers of the type series VersiStart II are called "devices", however, in the sense of the "law on the safety of equipment", the "EMC-law" or the "EC-machinery directive" they are not devices or machines ready for use or connection but they are components. It is only possible to define their final function, when these components are integrated into the design and construction of the user.

**To be able to use the devices to their intended purpose, it requires power supply networks according to DIN EN 50160 (IEC38).**

The user takes the responsibility that the user's design and construction comply with the applicable legal provision.

The commissioning is strictly forbidden as long as the conformity of the final product with the guidelines 2006/42/EC (Machinery directive) and 2006/95/EC (Low voltage directive) is not proved.

---

### 3. General description

In the case of the soft starters of the VersiStart II type the motor voltage is changed in two phases (1L1/5L3) by a generalized phase control and power semiconductors. Starting from an adjustable starting trigger angle the trigger angle is continually reduced. Via the adjusted ramp-up time the motor voltage increases according to a ramp function until the maximum value is reached. When the acceleration time is over, the power semiconductors are bypassed by integrated relays and the motor is directly supplied with power from the mains.

After opening of the start/stop-contact, the trigger angle is continuously increased via a ramp-function, and, as a result, the motor voltage is decreased. The motor softly decelerates with the adjusted deceleration time.

Acceleration time, starting voltage and deceleration time can be separately adjusted via potentiometers.

Acceleration or deceleration are effected by closing or opening of the contact on the terminals X1/X2.

The boost function is switched on by bridging the terminals X1/X3. Thus, at the beginning of the soft start, an increased starting voltage is applied to the motor for a period of 0,5s.

The power supply to the control electronics is effected via the power section. On request, the power supply can also be implemented via an external power supply unit (24V min. 150mA DC).

The devices are suitable for an operation of 3-phase motors in star or delta connection. Interconnection of motors in a so-called  $\sqrt{3}$ -connection is possible as well.

For  $\sqrt{3}$ -connection, it is necessary to use a main contactor K1, since one motor winding lies directly between two phases.

### 4. Usage to the intended purpose

The devices of the VersiStart II-series are electrical equipment that is used in industrial electrical power installations. They are designed for application in machines, in order to reduce the starting torque and starting current peaks as well as the tripping torque of drives with three-phase induction motors.

#### Typical Applications:

- door and gate drives
  - pumps, ventilators, fans
  - conveying systems
  - packaging machines
  - transport systems, assembly lines
  - machine applications
-

**5. EC Declaration of Conformity**



**EC Declaration of Conformity** 

The manufacturer / company placing the product on the market  
(authorized representatives of the manufacturer / companies placing the product on the market  
that are established within the Community)

Name / Address: Peter Electronic GmbH & Co.KG  
Bruckäcker 9  
92348 Berg  
Germany

hereby declares that the following product (device, component, unit) in the version as supplied

**Product designation:** **Softstarter**  
Serien / type designation: VS II 230...690-17...45; B; M; UL; D; H  
Article group: 257...  
Year of manufacture: 2005

complies with the provisions of the following EC-directives:

**2004/108/EG** concerning Electromagnetic compatibility and **2006/95/EG** concerning Electrical equipment designed for use within certain voltage limits

**The following harmonized standards have been applied:**

EN 60947-1: 2008	Low-voltage switchgear and controlgear General rules	EN 60947-4-2: 2007	Low-voltage switchgear and controlgear Contactors and motor-starters - AC semiconductor motor controllers and starters
------------------	---	--------------------	---

This EC Declaration of Conformity is no longer valid, if the products is modified or changed  
without our agreement.

This declaration is issued under the sole responsibility of the signatory.

Berg, 05.08.2009  
(place, date)

Dr. Thomas Stiller, Managing Director  
(signatory and function of the signatory)

  
(signature)

## 6. Block diagram

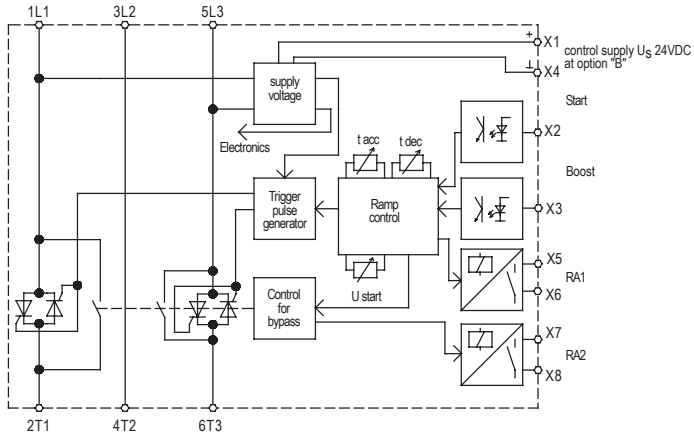

## 7. Commissioning

The device is to be put into operation in 3 steps:

1. Mounting
2. Connection and
3. Parameter setting

**Note:**

Please notice the max. permissible starting current (under 7/Technical data).

### 7.1 Mounting instructions

**Caution: Danger to life through electric shock!**

The following conditions are to be complied with in order to ensure a safe and reliable operation of the VersiStart II.

1. The device series VersiStart II is to be used under conditions of the overvoltage category III.
2. Make sure that pollution degree 2 or better, in accordance DIN EN60644-1 / IEC664, is complied with.
3. The device has to be installed into a housing (min. degree of protection: IP54). Please take care of a sufficient heat dissipation.
4. The device must be operated without being exposed to contamination by water, oil, carbon deposits, dust, etc..
5. Insert in North America, UL and CSA-listed.
  - 5.1 'Suitable For Use On A Circuit Capable Of Delivering Not More Than 5kA rms Symmetrical Amperes, 600 Volts Maximum' and 'When Protected by A Circuit Breaker type N2MB2-AF63-NA 63A, 600 Volts Maximum.'
  - 5.2 'Use Copper Conductors 60/75°C, or 75°C only.'

Place the device vertically on a perpendicular mounting plate with the motor terminals pointing downwards. The device is to be snap-mounted onto a 35mm top-hat rail according to DIN EN 50022. Underneath the device, no additional heat sources such as heating resistors must be mounted or arranged.

---

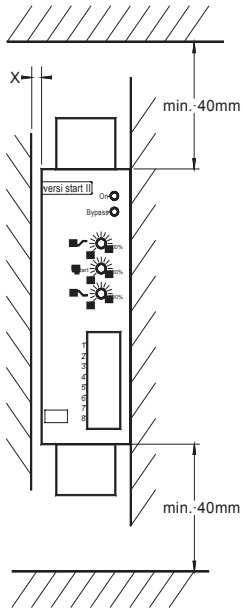

### Clearance X

Under normal drive conditions, the devices can be mounted side by side.

In the case of applications requiring high starting frequencies and / or high-inertia starting, the devices should be mounted with a distance of approx. 10mm in between them, in order to ensure good ventilation of the heat sink.



### Warning:

To avoid heat concentrations, a distance of at least 40mm is to be kept between cable duct and device.

## 7.2 Connection

### Power section (see also connection diagram)

Terminal 1L1:	Mains voltage L1
Terminal 3L2:	Mains voltage L2
Terminal 5L3:	Mains voltage L3
Earth connection 	PE
Terminal 2T1:	Motor terminal U
Terminal 4T2:	Motor terminal V
Terminal 6T3:	Motor terminal W

### Control section

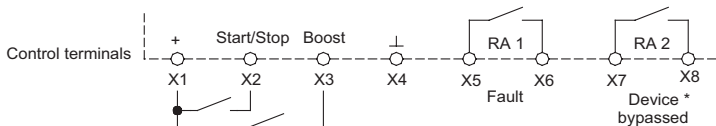

The input resistance of the control inputs is 10kOhm. To control them, it is necessary to use switching contacts enabling reliable switching of the lower control currents (e.g., AgNi+Au)!

If the contact on the terminals X1 a. X2 is closed, the motor accelerates with the adjusted acceleration time ramp. When the contact is open, the motor decelerates with the adjusted deceleration time ramp.



### Caution: Danger to life through electric shock!

The motor is **not** physically separated from the mains.

Alternatively, the device can also be controlled with d.c. voltage.

If only soft starts are required, VersiStart II may also be controlled via the main contactor. For this purpose, the terminals X1 and X2 have to be bridged.

\* In case of devices with ext. control supply voltage 230VAC the supply will connected here (see 13.5.2).

### Adjusting the control type

Devices of the VersiStart II series may be controlled by two types of control.



1. Control with a switching contact or switching transistor between terminal X1 and X2.
2. Control by d.c. voltage 10 ... 24VDC between terminals X2 and X4.

### Control supply voltage $U_S$ only in the case of wide-voltage devices (option B)



Between the terminals X1 (+) and X4 (⊥) an auxiliary voltage of 24VDC  $\pm 10\%$ /150mA is to be injected.

### 7.3 Parameter settings

On the front panel there are 3 potentiometers by means of which the following settings can be made.







Parameter	Poti	Setting range
Acceleration time	$t_{\text{acc}}$ 	Acceleration time adjustable from 0.5...10sec
Starting voltage	$U_{\text{Start}}$	40...80% of rated voltage
Deceleration time	$t_{\text{dec}}$ 	adjustable from 0.5...10sec

#### Default setting of potentiometers:

- Potentiometer  $t_{\text{acc}}$   (acceler. time) = mid-position  
 Potentiometer  $U_{\text{Start}}$  (starting voltage) = left stop (counter-clockwise)  
 Potentiometer  $t_{\text{dec}}$   (deceler. time) = left stop (counter-clockwise)

#### Adjusting soft start

To adjust an optimum starting behavior, you should carry out a test run. Contrary to the default settings, you should make the following basic potentiometer-settings.

Fans, roller tracks, conveyor belts, etc.	$t_{\text{acc}}$  50%, $U_{\text{Start}}$ 0%, $t_{\text{dec}}$  0%
Centrifuges, conveyor screws, mixers, compressors, etc.	$t_{\text{acc}}$  50%, $U_{\text{Start}}$ 50%, $t_{\text{dec}}$  50%
Pressure pumps, etc.	$t_{\text{acc}}$  50%, $U_{\text{Start}}$ 50%, $t_{\text{dec}}$  50%

Switch on the supply voltage and start acceleration. Watch the starting behavior and adapt the appropriate parameters to your drive. At any rate, the starting voltage should be adjusted with the potentiometer  $U_{\text{Start}}$  so that the motor starts immediately. At the same time, unnecessary humming with the motor being at rest is to be avoided.

The potentiometer  $t_{\text{acc}}$   is to be adjusted so that the requested acceleration time or starting characteristics is achieved. The acceleration time should always be chosen as short as possible, in order to keep the thermal stress acting on device and motor as small as possible. This leads to short times until the bypass relays pull in and ensures good acceleration characteristics while the power semiconductors and motor are less heated. This is of special importance in the case of high-inertia starting or high switching frequencies. The acceleration time, however, has to be adjusted so that the motor reaches nominal speed before the internal bypass relays close.



#### Warning:

If the adjusted acceleration time is too short, the internal bypass relays close **before** the motor has reached nominal speed. This can cause damage to the bypass relays.

### Adjusting soft stop

**Note:** Soft stop is only useful for pump drives or applications in the case of which the drive comes to a stop **immediately** after switch off. In the case of drives driving high-inertia loads, soft stop is not sensible.

**Note:** To enable soft stop, the VersiStart II, during the deceleration phase, has to be supplied with power from the supply mains.

In the case of these devices, the cut-off voltage is factory-set to 70%.

The potentiometer  $t_{\sim}$  is to be adjusted so that the requested deceleration time or deceleration characteristic is reached.



**Caution: Danger to life through electric shock!**

Even if the motor is at rest, it is **not** physically separated from the mains.



**Warning!**

Make sure that the specified switching frequency is not exceeded!

**Note:** If, in the motor circuit, a motor contactor that closes with the starting contact is used, the deceleration time  $t_{\sim}$  is to be set to 0%.

## 8. LED indicators

On the device front panel there are 2 light-emitting diodes indicating the following operational states.

LED	Operational status
Green	Device is connected to mains voltage
Yellow	Start completed, device bypassed
Yellow - flashing with increasing or decreasing frequency	Soft start / Soft stop
Yellow - flashing with constant frequency	Fault

On the control terminals X5 / X6 (RA 1) and X7 / X8 (RA 2) two signaling relays are available which signal the following operational states:

### RA 1 **Fault.**

Under normal operating conditions the signaling contact RA 1 is closed, it only opens if a fault occurs.

### RA 2 **Device bypassed.**

When the start-up ramp is over and the motor is supplied with nominal voltage or the bypass relays are closed, the signaling contact RA 2 will be closed.

### 8.1 Option „M“

The signaling contact RA 2 will be closed when acceleration is started. After deceleration is finished the signaling contact will be opened again.

## 9. Fault

The device series VersiStart II monitors various fault conditions. If a fault is detected, the device signals the fault with the yellow LED (flashing at constant frequency). In the case of a fault, the signaling relay RA 1 is opened. The various fault conditions are indicated via different flashing frequencies of the yellow LED.

### 9.1 Fault description

Fault	LED	Operational status
1	Yellow LED flashing 2x repeatedly with a short pause	Heat sink temperature is too high/device is thermally overloaded, or in the case of devices with motor PTC (see 12.4) the motor temperature is too high.
2	Yellow LED flashing 3x repeatedly with a short pause	Electronics fault
3	Yellow LED flashing 4x repeatedly with a short pause	Mains phase failure / Trigger failure in phase 1
4	Yellow LED flashing 5x repeatedly with a short pause	Mains phase failure / Trigger failure in phase 3
5	Yellow LED flashing 6x repeatedly with a short pause	Motor phase failure / Power semiconductor(s) defective in phase 1
6	Yellow LED flashing 7x repeatedly with a short pause	Motor phase failure/ Power semiconductor(s) defective in phase 3
7	Yellow LED flashing 8x repeatedly with a short pause	General synchronization error/Mains or motor circuit defective

### 9.2 Fault remedy

In case of a fault, please proceed as follows:

- Fault 1: Check the frequency of starts and the starting current and also observe the max. ambient temperature. Give the device and/or the motor enough time between starts to cool down. The heat dissipation can be improved by forced cooling, e.g., by means of a fan mounted underneath the device or by using a motor with a separately driven fan.
- Fault 2: Defect in the internal control electronics. Send device to the producer to have it checked.
- Fault 3/4: Mains supply is interrupted. Motor lead interrupted, power semiconductor(s) defective, motor defective. Check motor and wiring. Send device to the producer to have it inspected.
- Fault 5/6: Mains supply is interrupted. Power semiconductors do not trigger. Motor rating is too small. Check as to whether the motor is suitable for the device rating. Send device to the producer to have it checked.
- Fault 7: Mains or motor wiring is interrupted. Power semiconductor(s) defective. Check wiring. Send device to producer to have it inspected.

### 9.3 Resetting of faults

There are two ways available to reset a device fault.

1. In as-delivered condition, the fault message can be reset by disconnecting and reconnecting the supply voltage. In the case of standard devices via L1, L2 and L3, and in devices with option "B" via 24VDC or 230VAC.
2. The device can be programmed such that a fault reset is possible through a restart (opening and closing of the start input). For this, it is necessary to proceed as follows.

First of all, the device has to be wired in compliance with the following connection diagrams.

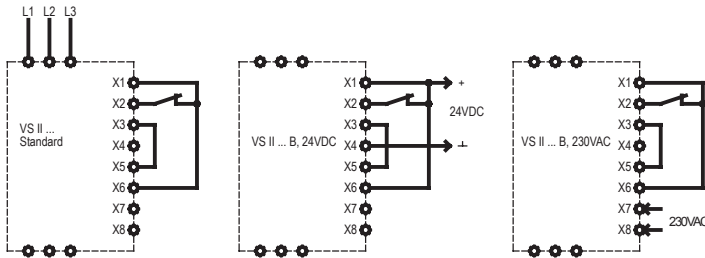

Afterwards, the supply voltage is to be switched on. In the case of standard devices via L1, L2 and L3; and in devices with option "B" via 24VDC or 230VAC. After a short period of time, the yellow LED flashes with a different frequency, depending on the reset mode adjusted.

- |                      |   |
|----------------------|---|
| Low flash frequency  | -> Fault reset through disconnection and reconnection of the supply voltage (standard setting). |
| High flash frequency | -> Fault reset through restart.   |

The reset mode can be changed by opening and closing the start input; the yellow LED blinks with the corresponding flash frequency, and the new mode is permanently stored.

Now, the supply voltage can be switched off again and the device is ready for installation in its application.



#### Warning:

At any rate, the cause of the fault has to be identified and remedied by trained and qualified personnel. Only then must the device be put into operation again.

**10. Technical data (standard)\***

Type designation, VersiStart	VS II 400-17	VS II 400.25	VS II 400-32	VS II 400-45
Mains / motor voltage acc. to DIN EN 50160 (IEC 38)	400V ±10% 50/60Hz			
Control supply voltage U <sub>S</sub> only in the case of option „B“	24VDC ±10%/150mA			
max. Motor rating at 380/415V (rated power)	7.5kW	11kW	15kW	22kW
Rated device current (I <sub>e</sub> )	17A	25A	32A	45A
max. Power dissipation - in operation - in standby	29.5W 7.5W	29.5W 7.5W	29.5W 7.5W	27W 7.5W
min. Motor load	20% of device rating			
Acceleration time	0.5 ... 10s			
Starting voltage	40 ... 80% of rated voltage			
Deceleration time	0.5 ... 10s			
Restart time	200ms			
max. Switching frequency at 3x I <sub>e</sub> and 5s 	60/h	40/h	30/h	10/h
Cross-sect. area for connection: Control terminals Power terminals	1.5mm <sup>2</sup> / AWG 16 6mm <sup>2</sup> / AWG 10		1.5mm <sup>2</sup> / AWG16 16mm <sup>2</sup> / AWG 8	
Tightening torque	1.2-1.5 Nm 11-13 lbs in		1.5-1.7 Nm 13-15 lbs in	
I <sup>2</sup> t - Power semiconductors	4000A <sup>2</sup> s	4000A <sup>2</sup> s	9100A <sup>2</sup> s	16200A <sup>2</sup> s
Contact rating of output relays RA 1 / RA 2	3A/250V AC 3A/30V DC			
Input resistance Control inputs	10kOhm			
Surge strength	4kV			
Weight	1kg			
Special voltages (optional)	230V / 480V / wide-voltage range 400-600V with control supply voltage U <sub>S</sub> 24VDC/150mA (Option „B“)			

\* For special voltages please see our supplement.

## 10.1 Environmental conditions

Storage temperature	-25 ... 70°C
Ambient temperature	0 ... 45°C up to an installation altitude of 1000m, not exposed to moisture condensation
Power reduction <sup>1)</sup>	above 45°C - 2% per 1°C up to max. 60°C and altitudes above 1000m -2% per 100m
Degree of protection	IP 20
Environment	Overvoltage categ. III (TT / TN-systems), pollution degree 2
Installation class	3

<sup>1)</sup> The reductions refer to rated power output.

## 11. Dimensioning rules

### 11.1 Dimensioning of fuses for device protection

Pre-fuses F can be dimensioned according to the following instructions.

Basically, two types of fuse protection are available for the user.

1. Fusing according to allocation type „1“, DIN EN 60947-4-2.  
After a short circuit, the VersiStart II device is allowed to be inoperative and repair work is possible.
2. Fusing according to allocation type „2“, DIN EN 60947-4-2.  
After a short circuit, the device must be suitable for further use. However, there is the danger that the contacts of the bypass or braking relays weld. Therefore, if possible, these contacts are to be checked prior to reconnecting these contacts to the mains supply. If this check cannot be carried out by the user, the device has to be returned to the producer in order to have it checked.

The following dimensioning information refers to the below operating conditions:

- Use of standard asynchronous motors
- Standard acceleration and/or deceleration times
- Switching frequencies not exceeding the values specified in the data sheet

### Fusing according to coordination class "1"

As pre-fuses, we recommend to use fuses of the utilization category gG or main power circuit-breakers or automatic circuit-breakers with tripping characteristic K. In the case of automatic circuit-breakers, attention is to be given to the tripping characteristic of the type series. With  $2 \times I_n$ , the tripping time should be at least 20s ( $I_1$ ).

If such fuses are also used to provide line protection, the conductor cross section is to be appropriately coordinated

**Short circuit protection according to EN 60947-4-2**

Rated device current (techn. data)	Device type	Fuse value in the case of allocation type 1	Starting frequencies Starts / h
17A	VS II 400-17	35A	50
25A	VS II 400-25	50A	35
32A	VS II 400-32	63A	25
45A	VS II 400-45	100A	10

**Short circuit protection according to UL 508 (Class RK5 fuse)**

Rated device current (techn. data)	Device type	Fuse RK5
17A	VS II 400-17	30A
25A	VS II 400-25	50A
32A	VS II 400-32	60A
45A	VS II 400-45	100A

**Fusing according to allocation type „2“:**

The power semiconductors are to be protected by semiconductor protection fuses of the utilization class aR or gR . However, since these fuses do not ensure line protection, it is necessary to use additionally line protection fuses (utilization category gG).

To protect the semiconductors it is necessary to select fuses featuring cutoff- $I^2t$ -values which are approx. 10-15% below the threshold  $I^2t$ -value of the power semiconductor (see technical data). In this connection, the fuse rating of the selected fuse should not be smaller than the starting current to be expected.

**Note:** PETER electronic does not prescribe the use of semiconductor protection fuses. However, for some UL- or CSA-listed devices there are exceptions which are indicated in the relevant commissioning instructions.

**Note 1** On the basis of the  $I^2t$ -value of the power semiconductors, the starting time and possibly the max. starting current, the fuse supplier is able to select a suitable type. Due to the great variety of producers, sizes and types, PETER electronic does not recommend any particular fuses.

**Note 2** If the value of the fuse or the cutoff- $I^2t$ -value is selected too small, it may happen that the semiconductor fuse reacts during the starting phase or during deceleration.

## 11.2 Determining the permissible starting frequency

The starting frequency depends on the:

1. starting current or the heat loss across the power semiconductors.
2. current carrying capacity and the temperature increase of the power semiconductors.
3. heat sink's capability of absorbing the heat loss and passing the temperature increase on to the environment.

The following diagrams are to assist you in determining the maximum starting frequency per hour, i.e., on the basis of the given maximum starting current and for various starting times.

Should the requested starting frequency not be reached, a different device series has to be chosen.

**Example:** In a drive, a 15 kW-motor is to be started. A maximum starting current of 120A has been measured. This approximately corresponds to the 4-fold nominal current. The device employed is a VS II 400-32. From the applicable chart it is now possible to read off a max. starting frequency per hour lying between 280 (starting time = 1s) and 28 (starting time = 10S).

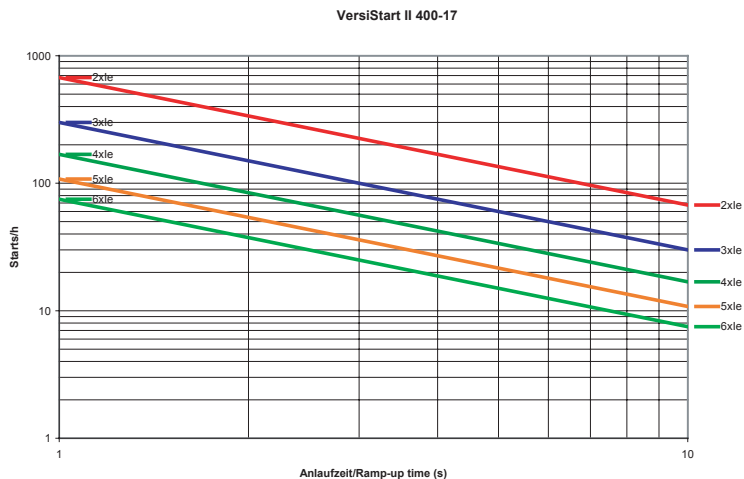

VersiStart II 400-25

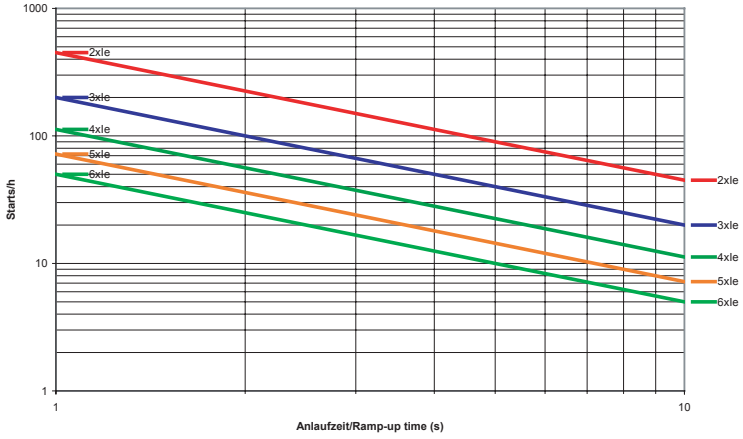

VersiStart II 400-32

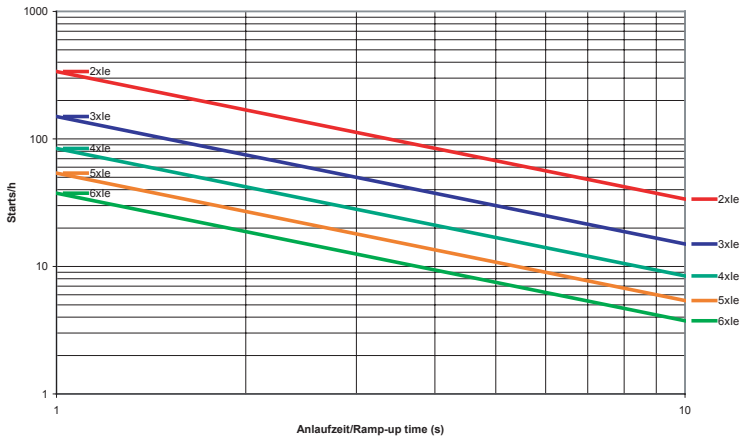

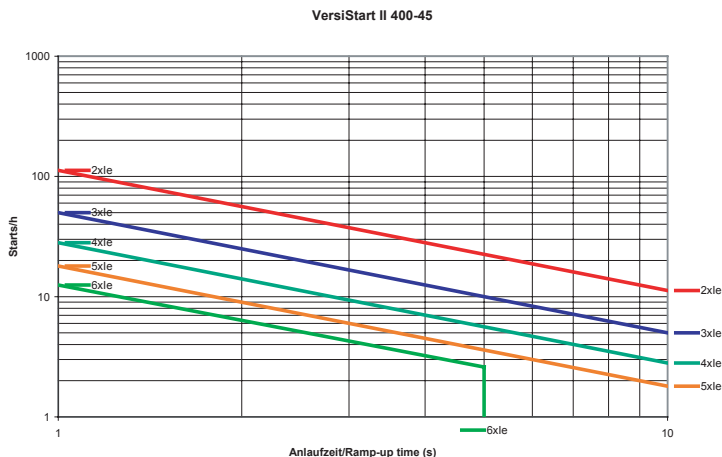

## 12. Special units

The rated voltage of a device featuring special voltage is indicated on the rating plate. In the case of devices with voltages < 400V it must be ensured that the device rating and the motor rating are not identical. Of prime importance in this connection is the rated device current and the motor current according to rating plate.

### 12.1 Devices with rated voltage of 230V or 480V

It must be ensured that the mains voltage value indicated on the rating plate is connected to the terminals L1, L2, L3.

Otherwise the devices are to be put into operation like standard devices.

### 12.2 Devices featuring a wide-voltage-range power section

In the case of wide-voltage-range-capable devices the voltage range for the power supply is 200V ... 480V. Besides, in order to operate the devices, it is necessary to connect an control supply voltage  $U_S$  of 24VDC  $\pm 10\%$ /150mA to the terminals X1 (+24V) and X4 (ground).

In case of devices with ext. control supply voltage 230VAC the supply will be connected to X7 and X8. The auxiliary contact „Device bypassed“ is not applicable on these devices!



#### Caution:

These devices must be reset by disconnecting the control supply voltage.

Otherwise the devices are to be put into operation like standard devices.

### 12.3 Devices featuring special voltage $\geq 500V$

Devices  $\geq 500V$  are equipped with power semiconductors featuring higher reverse voltages. These devices are to be connected and put into operation like devices having a wide-voltage-range power section.

### 12.4 Devices with motor-PTC input

In the case of these devices, it is possible to connect a motor-PTC for motor temperature monitoring. The sensor lines of the motor-PTC are to be connected to the terminals X3 and X4 (  $\perp$  ).

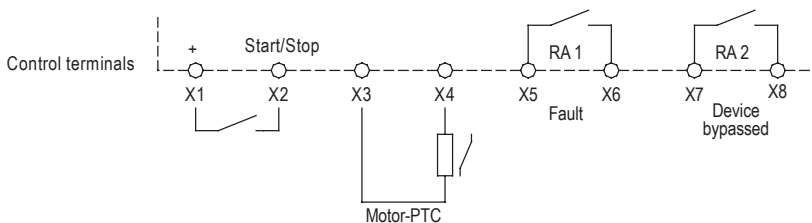

If the motor temperature exceeds the switching threshold, the motor PTC triggers a fault. The soft starter switches the motor off and is interlocked in fault mode. The fault is signaled by the yellow LED repeatedly flashing two times and by an opening of the relay contact between the terminals X5 and X6.

Let the motor cool down, identify the root cause and remove the cause of the intense heating up of the motor. By switching off the supply voltage, the soft starter can be reset from fault mode into operating mode.



#### Caution!

To avoid EMI couplings into the electronics and their disturbances they involve, it is not allowed to use free, unshielded strands in the motor cable for connecting the temperature sensor to the soft starter.

The temperature sensor should be connected with the soft starter by a separate, and preferably, shielded cable. The line ends are to be neatly terminated and unshielded lines must be kept as short as possible.

The sensor cable is, as far as possible, to be laid separately from the power cables in separate cable ducts. If crossings of power cables and control cables are inevitable, they should be arranged at an angle of  $90^\circ$ .

### 13. Installation guideline

The devices are to be installed into a switchbox or switchgear cabinet according to point 2 and 4. It must be ensured that the switchbox/switchgear cabinet is capable of dissipating the occurring heat loss (see techn. data).

#### 13.1 Connection

The device is to be installed according to the attached connection diagram. For other connections please consult PETER electronic GmbH & Co. KG.

##### 13.1.1 Earthing

The electrical earthing provided ensures a low impedance connection between all metallic surfaces. Apart providing a degree of electrical safety and isolation, the earthing also has the beneficial effect that the flow of RF currents can be directed through the structure of the equipment rather than through sensitive circuits, where it could be disruptive. It is for this reason that it is vitally important to provide separate earth conductors for each part of the installation all connected to a common star point.

##### 13.1.2 Cabling

To avoid EMI couplings into the electronics and the disturbances they involve, it must be ensured that the control cables are laid separately in separate cable ducts and as far as possible away from the power cables. If control cables crossing power cables, they have to be laid at an angle of  $90^\circ$  (Figure 3).

When connection shielded cables make sure that the unshielded cable ends are as short as possible. The large-surface shield bonding must not necessarily be located on the end of the shielding but may also be established in a suitable place - at a distance of some centimetres (Figure 4).

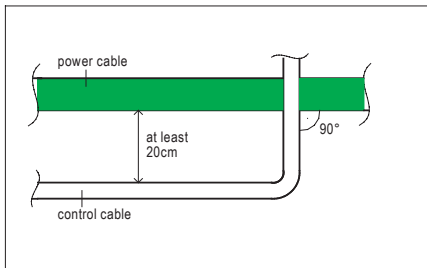

Figure 3

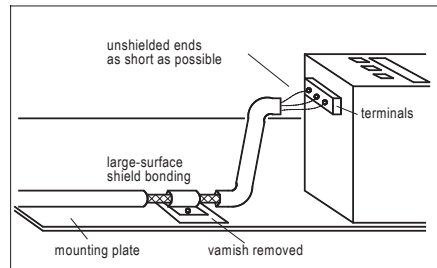

Figure 4



#### Caution:

The protective conductor connection to the motor must not be laid in shielded motor cables, but is to be separately laid with an appropriate cross-sectional area. The individual earthing systems, power earth, protective earth, digital earth, and analog earth conductors should be laid separately by using a suitable star-point wiring.

**Note:** Further connection diagrams for special circuit arrangements are available on our homepage at [www.peter-electronic.com](http://www.peter-electronic.com).

**Note:** Prior to putting the VersiStart II into operation the wiring is to be checked.

### 13.2 General connection diagram

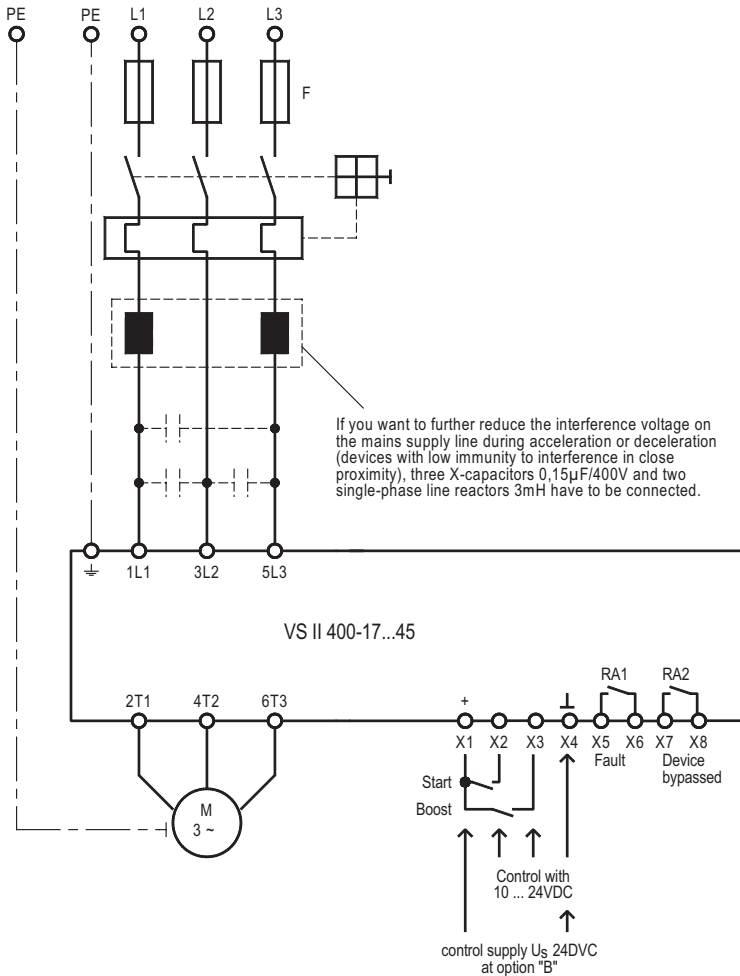

13.3 Typical connections

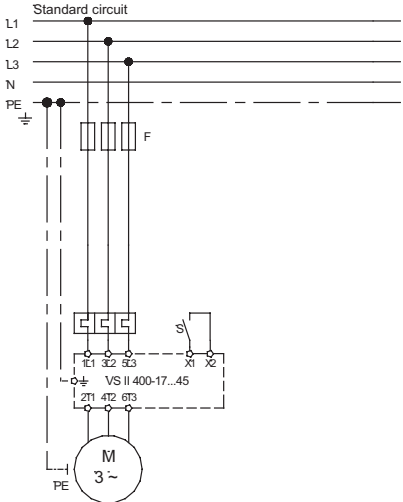

S - closed = acceleration; S - open = deceleration

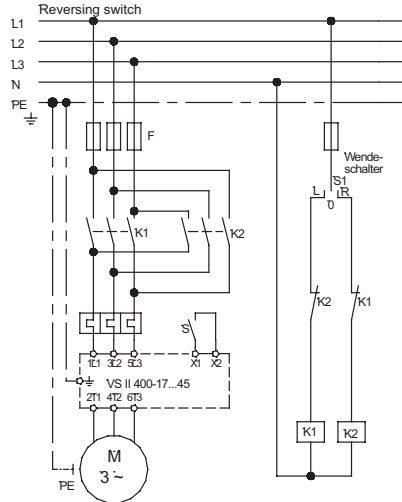

S - closed = acceleration; S - open = deceleration

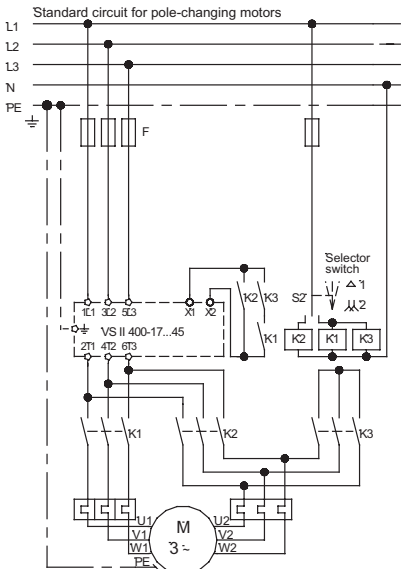

for pole-changing motors turn trimmer t off to 0 (counter-clockwise stop)

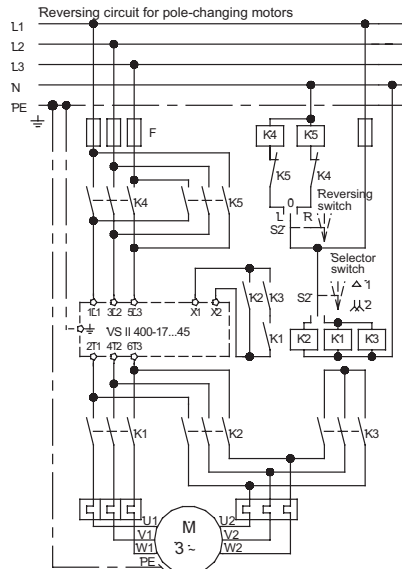

**13.4 Motor/Soft start in delta connection (only units with option „M“)**

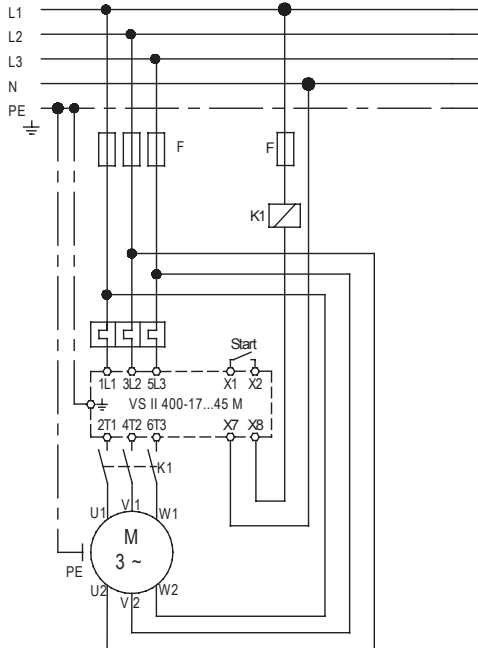

Further connection diagrams are available via the internet at [www.peter-electronic.com](http://www.peter-electronic.com)

## 13.5 Wide-voltage-range connection

### 13.5.1 Devices with control supply voltage 24VDC

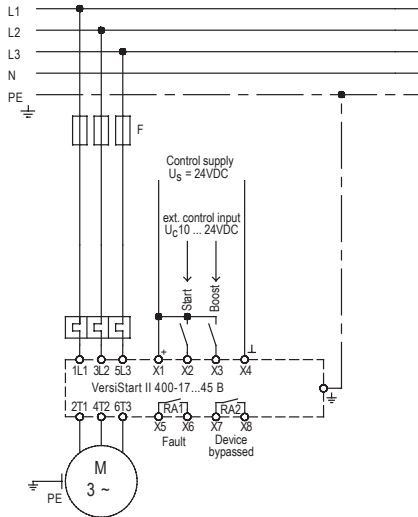

### 13.5.2 Devices with control supply voltage 230VAC

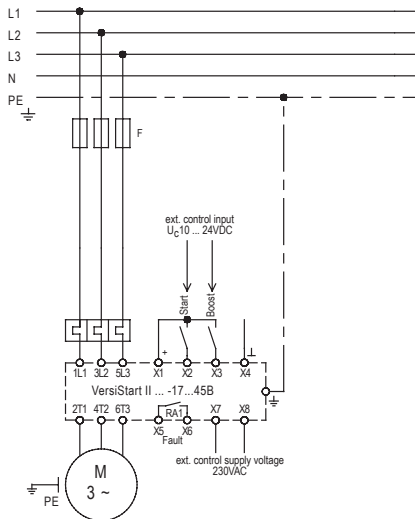

Further connection diagrams are available via the internet at [www.peter-electronic.com](http://www.peter-electronic.com)

### 14. Dimensions

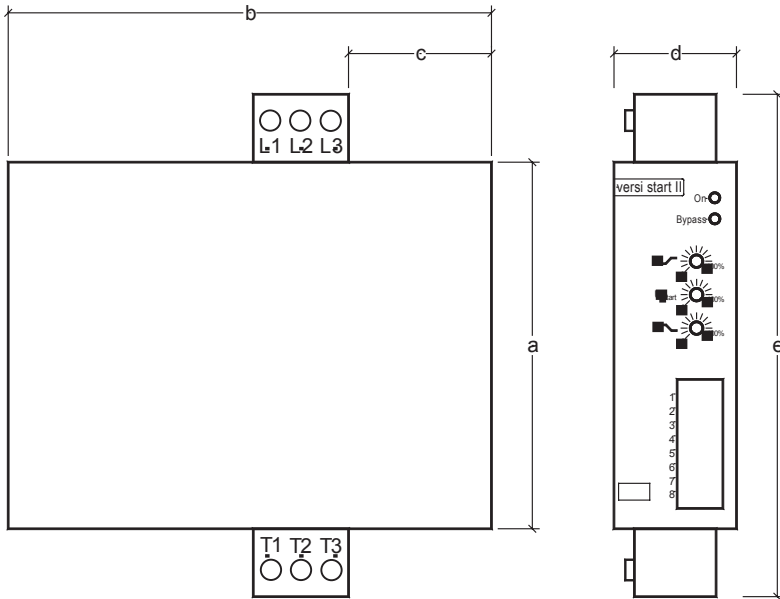

Mounting dimensions	a	b	c	d	e
VS II 400-17...32	125	158	53	45	173
VS II 400-45	125	158	53	52.5	178

All dimensions indicated in mm.

### 15. Special units

Please see supplement.





[www.peter-electronic.com](http://www.peter-electronic.com)

