

Braking Devices
VB 230/400-40 ... 600
Assembly- and Commissioning Instructions

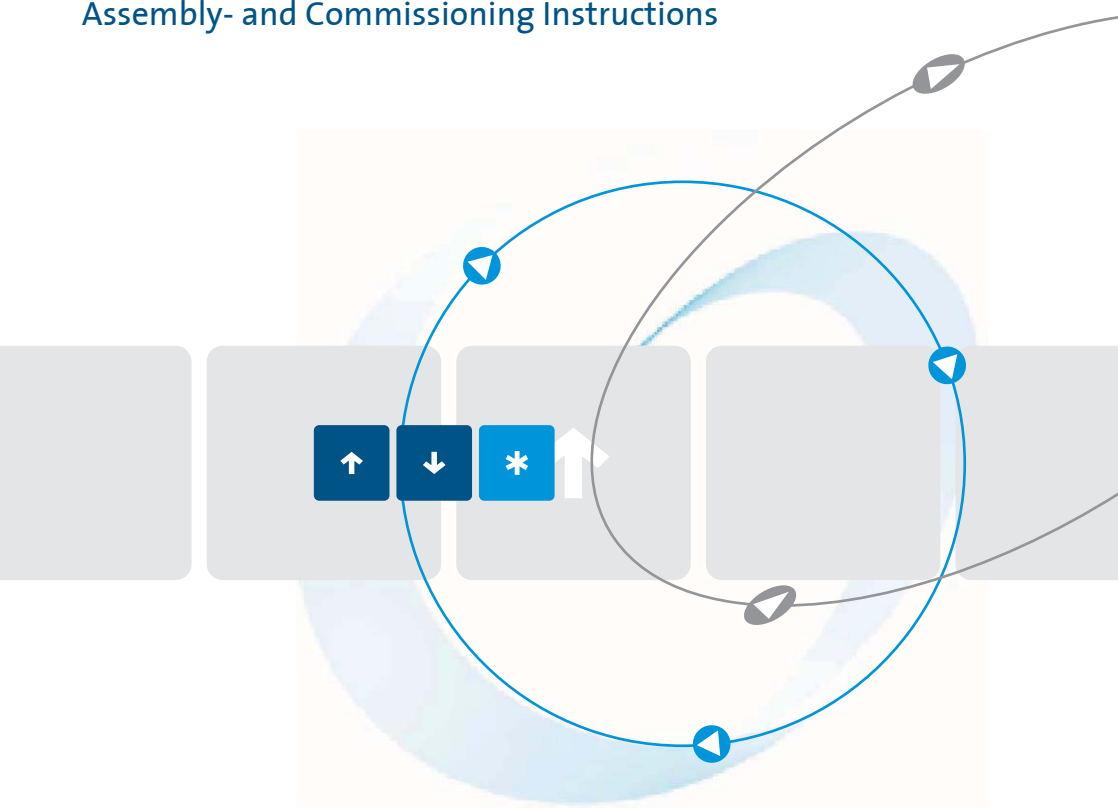

as per 04/10 19700.10001

Table of Contents	Page
1. Safety notes	3
2. Conformity	3
3. General description	4
4. Usage to the intended purpose	4
5. EC Declaration of Conformity	5
6. Block diagram	6
7. Functional description (see connection diagram)	6
7.1 Fault signaling relay	7
8. Control inputs and outputs	8
8.1 Control inputs	8
8.2 Control outputs	8
8.3 Control outputs – optional	9
9. Adjustments / Device configuration	10
10. Potentiometers	11
11. Display / LED Indicators	12
12. Options	12
12.1 Braking current display, Option „A“	13
12.2 Wide-voltage range, Option „B“	13
12.3 Plug-in control terminals, Option „C“	13
12.4 Motor PTC monitoring, Option „P“	13
12.5 Star-delta starting control, Option „P“	13
12.6 Standstill signaling relay, Option „P“	14
12.7 Signaling relay for braking current monitoring, Option „P“	15
13. Technical data	16
13.1 Ambient conditions	16
14. Commissioning	17
14.1 Mounting instructions	17
14.2 Connection	17
14.3 Commissioning	18
15. Dimensioning rules	19
15.1 Dimensioning of braking contactors	19
15.2 Dimensioning of pre-fuses	19
15.3 Permissible braking frequency	21

16. Dimensions	23
17. Typical connections	24
17.1 Connection diagram VB 230/400-40...60	24
17.2 Connection diagram VB 230/400-100...600	25
17.3 Connection diagram with all options VB ...-40...60	26
17.4 Connection diagram with all options VB ...-100...600	27
17.5 Connection diagram for special devices VB 480-40...60APBC	28
17.6 Connection diagram for special devices VB 480-100...600APBC	30

These commissioning instructions were prepared with great care. Nevertheless, PETER electronic GmbH & Co. KG does not assume liability for damage resulting from mistakes possibly contained in this manual. Technical changes that serve to improve the product are subject to change without notice.

Notes and symbols used in these instructions

Note: Notes explain the advantages of certain adjustments or settings and help you to make use of the device in the best possible way.



Warning notices: Read them carefully and follow them strictly!

Warning notices are indicated in order to protect you against danger or to help you to prevent the device from being damaged.



Caution: Danger to life through electric shock!

When you see this sign, always make sure that the device is de-energized and secured against unintentional energizing.

1. Safety notes



The described devices are electrical equipment for use in industrial electrical power installations. An impermissible removal of the covers during operation can cause serious damage to your health, since these devices contain live parts with high voltages.

Adjustment work may only be performed by trained staff observing the safety regulations. Assembly and mounting work may only be carried out with the equipment deenergized.

Make sure that all drive components are properly earthed.

Please read these commissioning instructions carefully before putting the device into operation.

Besides, the user must ensure that the devices and associated components are fitted and connected in accordance with the applicable local, legal and technical regulations. The VDE-regulations VDE 0100, VDE 0110 (EN 60664), VDE 0160 (EN 50178) , VDE 0113 (EN 60204, EN 61310), VDE 0660 (EN 50274) plus the appropriate regulations of the TÜV (Technical Control Association) and the trade associations apply in Germany.

The user must ensure that the drive turns into a safe operating state following a device failure, in the event of maloperation, or if the control unit has failed etc..

Caution: Even if the motor is at rest, it is **not** physically separated from the mains.

2. Conformity

In industrial linguistic usage the electronic brakes of the type series VersiBrake... are called "devices", however, in the sense of the "device-safety-law", the "EMC-law" or the "EC machinery directive" they are not devices or machines ready for use or connection but they are components. It is only possible to define their final function, when these components are integrated into the design and construction of the user.

To be able to use the devices to their intended purpose, it requires power supply networks according to DIN EN 50160 (IEC38).

The user takes the responsibility that the user's design and construction comply with the applicable legal provision.

The commissioning is strictly forbidden as long as the conformity of the final product with the guidelines 2006/42/EC (Machinery directive) and 2006/95/EC (Low voltage directive) is not proved.

3. General description

The electronic braking devices of the VersiBrake... type enable non-wearing braking of three-phase and a.c. asynchronous motors. The braking devices are used for drives that, due to safety and functional reasons, have to be reliably slowed down.

Depending on the setting chosen by the user, the braking current is switched off either when the adjusted braking time is over or when the integrated standstill detection signals that the motor has come to a standstill. In the case of standstill-dependent braking a potential-free signaling contact signals if the motor has not come to a standstill within the maximum braking time.

The braking current is regulated to the adjusted value (maximum: rated device current). The device option featuring „current display" shows the braking current setpoint value and, during braking, the braking current actual value..

Special features

- controlled by microcontroller
- wear-resistant and maintenance-free
- retrofitting into existing plants possible
- for all asynchronous motors
- integrated braking contactor (devices up to 60A)
- automatic remanence time optimization
- braking current control
- thermal overload monitoring
- braking current display with option „A"
- wide-voltage range 200-690V with option „B"
- plug-in control terminals with option „C"
- motor PTC monitoring with option „P"
- star-delta starting control with option „P"
- standstill signaling relay with option „P"
- braking current monitoring with option „P"



Warning !

Prior to using the standstill signaling contact for safety-directed purposes, it is necessary to subject the application to a risk assessment according to EN 1050 (ISO 14121).

4. Usage to the intended purpose

The devices of the VersiBrake series are electrical equipment that is used in industrial electrical power installations. They are designed for the application in machines, in order to slow down rotating masses on drives with three-phase a.c. motors.

Typical applications

- sawing machines
 - centrifuges
 - wood working machines
 - conveying systems
 - textile machinery
-

5. EC Declaration of Conformity

EC Declaration of Conformity 

The manufacturer / company placing the product on the market
(authorized representatives of the manufacturer / companies placing the product on the market
that are established within the Community)

Name / Address: Peter Electronic GmbH & Co.KG
Bruckäcker 9
92348 Berg
Germany

hereby declares that the following product (device, component, unit) in the version as supplied

Product designation: **Braking Device**
Serien / type designation: VB ... - 40...600..
Article group: 297..., 22..., 253...
Year of manufacture: 2002

complies with the provisions of the following EC-directives:

2004/108/EG concerning Electromagnetic compatibility and **2006/95/EG** concerning Electrical equipment designed for use within certain voltage limits

The following harmonized standards have been applied:

EN 60947-1: 2008	Low-voltage switchgear and controlgear General rules	EN 60947-4-2: 2007	Low-voltage switchgear and controlgear Contactors and motor-starters - AC semiconductor motor controllers and starters
------------------	---	--------------------	--

This EC Declaration of Conformity is no longer valid, if the products is modified or changed without our agreement.

This declaration is issued under the sole responsibility of the signatory.

Berg, 05.08.2009
(place, date)

Dr. Thomas Stiller, Managing Director
(signatory and function of the signatory)

(signature)

6. Block diagram

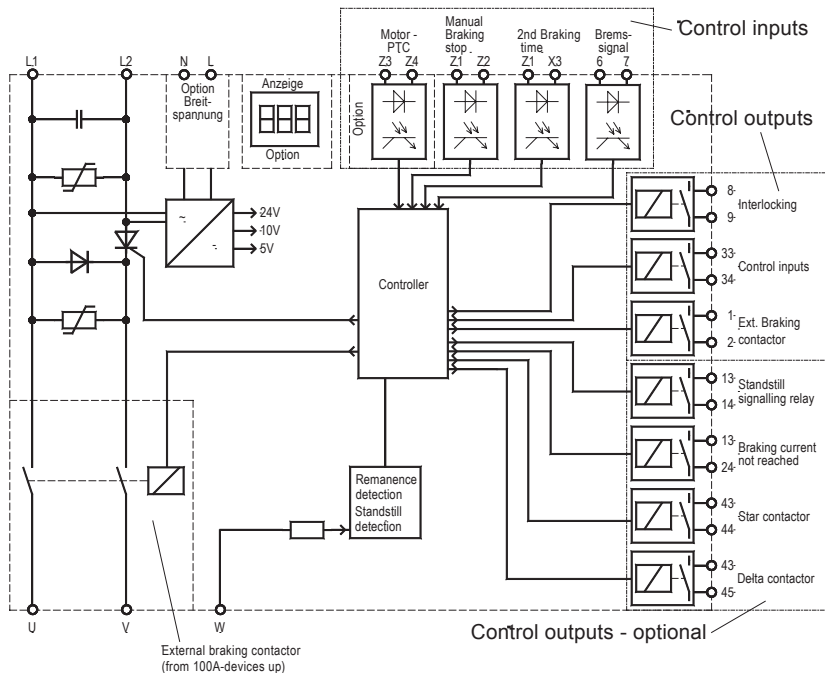

7. Functional description (see connection diagram)

After switching on the operating voltage on L1 and L2 (in the case of option „B“: on N and L) the main contactor interlock (terminals 8 and 9) and the fault signaling contact (terminals 33 and 34) close. The motor can be started.

A starting logic makes sure that, when switching the plant on with the master switch while the motor is still switched off, braking is not yet initiated.

The fully automatic run of the braking interval starts with the switch-off of the motor contactor which closes the terminals 6, 7. In the case of very dirty or corroded control contacts, it may happen that the current of 10mA required for starting cannot flow via the contacts 6 and 7, as a result of which a braking operation is not started either. In such cases, it is necessary either to change the control contact or to connect a relay as a link between the control contact of the motor contactor and the starting contacts 6 and 7. During braking, the main contactor is interlocked via the contacts 8, 9. After a delay time which, dependent on the amount of the remanent voltage of the motor, optimizes itself, the internal braking relay (devices up to 60A) and in the case of devices from 100A up the control contact for the external braking contactor on the terminals 1 and 2 closes. Then an adjustable d.c. voltage is applied to the motor winding. The magnetic field

resulting from this has a braking effect on the still rotating rotor. The d.c. voltage is generated by a thyristor phase control. Special suppressor circuits protect the power semiconductors against overvoltage. With the potentiometer "I" the braking torque can be adjusted within a wide range. Experience shows that a braking current 2.5 times as high as the rated motor current has a good braking effect.

By means of plug-in jumpers the user can choose time-dependent or standstill-dependent braking.

In the case of standstill-dependent braking, the integrated standstill detection switches the braking current off (approx. 1.5s after the motor standstill has been detected). If during the maximum braking time (selectable via plug-in jumpers: 10s, 20s or 40s) no standstill of the motor is detected, the fault signaling contact on the terminals 33, 34 opens. This state will be reset when the motor is restarted.

In the case of time-dependent braking it is possible via plug-in jumpers to select time intervals from 0.5...15s, 0.5...40s or 2...320s.

**Warning:**

In the case of braking times exceeding 40s, the braking current is to be reduced according to Attention!, page 22, and, at any rate, the motor temperature should be monitored. As in such cases it may happen that the braking device becomes thermally overloaded, braking has to be stopped when a fault signal occurs due to overtemperature.

7.1 Fault signaling relay

The following states on the fault signaling contact (terminal 33, 34) are possible:

No voltage applied to VersiBrake	Contact 33, 34 open
Voltage applied to VersiBrake, no fault	Contact 33, 34 closed
Overtemperature	Contact 33, 34 open
Braking current is not reached	Contact 33, 34 open ¹⁾
No standstill during monitoring time	Contact 33, 34 open ¹⁾

¹⁾ Contact closes at motor restart.

8. Control inputs and outputs

8.1 Control inputs

Control terminals	Designation	Description
6, 7	Starting contact	Connection of a break contact of the motor contactor
Z1, Z2	Manual braking stop	Bridging of Z1-Z2 causes an instant termination of braking. Prior to restarting the motor, the bridging has to be removed, as braking will not be effected with a closed bridging.
Z1, X3	2nd Braking time	If Z1-X3 are bridged, the braking time, which can be adjusted with „t2“ (0 –40s), is active. This 2nd braking time is not available with option „P“ in the case of which „t2“ can be used to adjust the pull-in time of the star contactor.
Z3, Z4	Motor PTC	see Chapter 12.4, Page 13

8.2 Control outputs

Control terminals	Designation	Description
8, 9	Interlock	The interlock prevents the motor from being switched on during braking. Loop the normally closed contact into the branch of the motor contactor.
33, 34	Fault signal	In the case of a fault this fault signaling contact opens. For closer details on the tripping characteristics please see chapter 5.
1, 2	External braking contactor	With the VB...-100...600 the braking current will be switched via a circuit breaker. As for the connection of this contact, please refer to the connection diagram in chapter 15.2 and 15.4.

8.3 Control outputs – optional

Control terminals	Designation	Description
13, 14	Standstill signal	In the case of standstill-dependent braking, a contact can be evaluated. For closer details regarding the tripping behavior please refer to chapter 10.6.
13, 24	Braking current is not reached	Contact closes if the braking current is not reached.
43, 44	Y - contactor	Control contact for the star contactor. For closer details please refer to chapter 10.5.
43, 45	Δ - contactor	Control contact for the delta contactor. For closer details please refer to chapter 10.5.

9. Adjustments / Device configuration

With the plug-in jumpers / switch BR1 to BR5 on the braking device it is possible to adjust the type of braking, the braking time, the type of reset and in the case of the „Motor PTC“ option the type of the temperature detector.

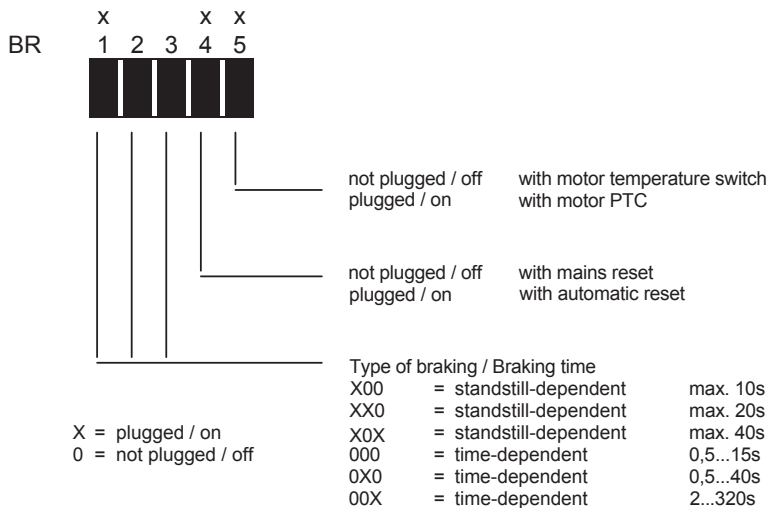

Warning!

In the case of braking times exceeding 40s, the braking current has to be reduced according to Attention!, page 22.

Behaviour of the fault signal with the corresponding type of reset:

Fault	Mains Reset	Automatic Reset
Overtemperature	Fault will be reset after cooling down and a short-time disconnection from the supply mains (at least 5s).	Fault will be reset after cooling down
Braking current not reached	Fault will be reset after a short-time disconnection from the supply mains (at least 5s).	Fault will be reset at motor restart.
No standstill during monitoring time	Fault will be reset at motor restart.	Fault will be reset at motor restart.
3x in succession no standstill during monitoring time	Fault will be reset after a short-time disconnection from the supply mains (at least 5s)	Fault will be reset after a short-time disconnection from the supply mains (at least 5s)

10. Potentiometers

With the potentiometers on the front panel of the VersiBrake-devices the following parameters can be adjusted.

„I“

Adjusting the braking current setpoint value.

The braking current can be adjusted within a range from 0 – 100% of the rated device current. The adjustment is linear.

In the case of devices featuring display the braking current is indicated.

In the case of devices without display it is possible to infer the amount of the braking current from the position of the potentiometer.

In this connection, a graduation mark corresponds with 10% of the rated device current.

„t1“

Adjusting the braking time.

In the case of time-dependent braking the braking time can be adjusted in the ranges defined with the jumpers BR2 and BR3. The adjustment is linear.

„n0“

Adapting the standstill threshold in the case of standstill-dependent braking.

If in special applications the motor standstill is not properly detected, this potentiometer can be used in order to re-adjust the standstill threshold in a small range.

In „right stop“ (full counter-clockwise) position, the standstill detection function is most sensitive, and the braking behavior, upon reaching the motor standstill, is most soft.

„t2“

Adjusting the 2nd braking time or the star contactor pull-in time (with option „P“)

If the 2nd braking time is selected via the control terminals Z1, X3, this potentiometer can be used in order to adjust it in the range from 0.5...40s. The adjustment is linear.

In the case of devices featuring option „P“, the star contactor pull-in time can be adjusted in a range from 3 ... 15s. With option „P“, however, a 2nd braking time is not available.

11. Display / LED Indicators

Without Display	With Display, Option „A“	Description
LED 2 illuminated	Current setpoint value is displayed	Supply mains is applied / ready for operation
LED 1 illuminated LED 2 and LED 3 alternately illuminated	Current actual value is displayed ¹⁾ DP1 and DP2 are alternately illuminated	Braking current is flowing
LED 3 illuminated		Standstill-dependent braking selected
LED 2 and LED 3 permanently flashing	¹⁾ DP1 and DP2 permanently flashing	No standstill during monitoring time
LED 2 and LED 3 flashing 2x	¹⁾ DP1 and DP2 flashing 2x	Overtemperature (motor or heat sink)
LED 2 and LED 3 flashing 4x	¹⁾ DP1 and DP2 flashing 4x	Braking current setpoint value not reached
LED 2 and LED 3 flashing 5x	¹⁾ DP1 and DP2 flashing 5x	3x in succession no motor standstill detected

¹⁾ DP1 and DP2 are the decimal points of the LCD-display

12. Options

For special applications there are various options in order to extend the functionality of Versi-Brake-devices.

The following is available:

- Braking current display - Option „A“
- Wide-voltage range 200-690V- Option „B“
- Plug-in control terminals- Option „C“

The following functions are only available as a package in the form of - Option „P“:

- Motor PTC monitoring
- Star-delta starting control
- Standstill signaling relay
- Signaling relay for braking current monitoring

Attention! In the case of option „P“, it is not possible to select a 2nd braking time by bridging Z1-X3.

12.1 Braking current display, Option „A“

In the case of this option the braking current setpoint value and the braking current actual value are displayed via a 3-digit LCD-display (height of digits: 13mm).

If mains voltage is applied to the VersiBrake, the braking current setpoint value adjusted on „I“ is displayed.

During the braking operation the braking current actual value is displayed. The active braking operation is displayed by alternating flashing of the decimal points (DP1 and DP2).

The decimal points indicate various fault conditions by different flashing frequencies.

12.2 Wide-voltage range, Option „B“

With this option it is possible to use the VersiBrake-devices in a wide voltage range.

VB 480 - ...B 200-480V

VB 600 - ...B 200-600V

VB 690 - ...B 200-690V

This requires a AC-control voltage that is to be connected to the terminals N and L.. The height of the control voltage is on the nameplate (24VAC, 110VAC, 230VAC).

12.3 Plug-in control terminals, Option „C“

This option features plug-in control terminals (Combicon).

12.4 Motor PTC monitoring, Option „P“

This option enables monitoring of the motor temperature. It is possible to evaluate up to 6 series-connected PTC thermistors (with BR5 plugged-in) or temperature switches (with BR5 not plugged-in). When using switches, the contacts must open in case of overtemperature.

The fault signal on the terminals 33, 34 shows when the shutdown temperature is reached. If BR4 (plug-in jumper for "Automatic Reset") is plugged in, the fault will be reset after cooling. If "Mains Reset" has been chosen (BR4 not plugged-in) the fault will be reset after cooling and a short-time disconnection from the supply mains (at least 5s).

When using PTC thermistors, overtemperature, line breaks and short circuits are detected.

If no motor PTC or temperature switch is connected to devices featuring option „P“, the terminals Z3 + Z4 have to be bridged and BR5 (see chapter 7, page 9) is to be removed.

12.5 Star-delta starting control, Option „P“

If star-delta starting is requested, it is with this option possible to control the power contactors.

In this case, a break contact of the mains contactor is to be connected to the terminals 6, 7 (see connection diagram with options).

Closing of the mains contactor starts the following sequence:

1. The potential-free contact on terminals 43, 44 is closed. (Control of the star contactor)
2. After an adjustable time has elapsed, the potential-free contact on the terminals 43, 44 is opened.
3. After a changeover delay of 60ms the potential-free contact on the terminals 43, 45 is closed (control of the delta contactor)

Opening of the mains contactor starts the following sequence:

1. The potential-free contact on the terminals 43, 45 is opened (delta contactor is switched off).
2. After the remanent voltage has dropped, the potential-free contact on the terminals 43, 44 is closed (control of the star contactor)
3. After the contact bounce time has been waited out the braking operation is started.

The star contactor pull-in time can be adjusted with potentiometer „t2“ in the range from 3...15s.

In the case of star-delta starting, even if it is not implemented via the VersiBrake-device, the star contactor should be controlled via the contact on the terminals 43 and 44 (option „P“), in order to effect braking. Thus, the motor windings are interconnected in time prior to the actual braking operation.

Note! To ensure that, in the case of external star-delta control, the starting operation is not influenced by the VersiBrake, a break contact of the motor contactor K1 has to be connected in series before the terminals 43 and 44.

12.6 Standstill signaling relay, Option „P“

This option provides the motor standstill signal to a potential-free contact on the terminals 13, 14.

Attention: only in the case of standstill-dependent braking (plugged-in BR1)

Possible states of the potential-free contact on the terminals 13, 14:

Voltage is not applied to VersiBrake	Contact 13, 14 open
Voltage is applied to VersiBrake	Contact 13, 14 closed
Motor contactor K1 pulled in (6, 7 open) Motor runs	Contact 13, 14 open
Motor contactor K1 dropped out (6, 7 closed) Motor brakes	Contact 13, 14 open
Motor contactor K1 dropped out (6, 7 closed) Motor stands still	Contact 13, 14 closed

**Warning note:**

Prior to using the standstill signaling contact for safety-directed purposes, it is necessary to subject the application to a risk assessment according to EN 1050 (ISO 14121).

12.7 Signaling relay for braking current monitoring, Option „P“

Via a potential-free contact on the terminals 13, 24 this option signals if the braking current adjusted with „I“ is not reached.

In its normal position, and if the device is in proper condition, the contact is open. It closes if the braking current is not reached.

Note! Standard devices do not provide these options, even if corresponding terminals are available.
When placing your order, please indicate the options you require.

13. Technical data

Type designation VB ...	230-40 400-40	230-60 400-60	230-100 400-100	230-200 400-200	230-250 400-250	230-400 400-400	230-600 400-600
Mains voltage according to DIN EN 50160 (IEC 38)	220/240V ±10% 50/60Hz (standard) 380/415V ±10% 50/60Hz (standard) 200 - 690V ±10% 50/60Hz (wide-voltage range)						
Power draw of electronics	6 VA						
Recommended for rated motor currents up to	20A	30A	50A	100A	125A	200A	300A
Rated device current	40A	60A	100A	200A	250A	400A	600A
c.d.f. at max. braking current	20%						
I ² t - value of power semiconductors in A ² s	1.050	4.900	6.050	80.000	80.000	320.000	1.125.000
Braking voltage	0 ... 130VDC at 220/240V (standard) 0 ... 220VDC at 380/415V (standard) 0 ... 380VDC (wide-voltage range) (690V)						
max. Braking time	40s with standstill-dependent braking 320s with time-dependent braking						
Contact rating of output relays	3A/250VAC 3A/30VDC						
Delay time for reduction of residual e.m.f.	self-optimizing (200 ... 3100ms)		self-optimizing (1600 ... 3100ms)				
max. Cross-sectional area / connecting cable	16mm ²	16mm ²	16mm ²	35mm ²	35mm ²	Screw M12	

13.1 Ambient conditions

Storage temperature	-25 ... 75°C
Operating temperature	0 ... 45°C
Degree of protection	IP 20
Environment	Overvoltage category III, Pollution degree 2

14. Commissioning

The device is to be put into operation in 3 steps:

1. Mounting
2. Connection and
3. Parameter setting

14.1 Mounting instructions



Caution: Danger to life through electric shock!

The following conditions are to be complied with in order to ensure a safe and reliable operation of the VersiBrake.

1. The device series VersiBrake is to be used under overvoltage conditions of the category III.
2. Make sure that pollution degree 2 or better, in accordance with IEC664, is complied with.
3. The device is to be installed into a housing (min. degree of protection: IP54).
4. The device must be operated without being exposed to contamination by water, oil, carbon deposits, dust, etc..



Warning:

Make sure that a minimum distance to adjoining devices is kept. Above and underneath the housing a minimum distance of 50mm is to be kept.

14.2 Connection

The braking device is to be installed according to the attached connection diagram. For other connections please consult Peter electronic GmbH & Co. KG.

Note: Further connection proposals for special circuit arrangements are available via our homepage at www.peter-electronic.com.

Note: Prior to putting the motor brake into operation, the wiring has to be checked.

To ensure reliable functioning, it is important to comply with the interlocking conditions:

1. To initiate braking, a potential-free break contact of the main contactor is necessary, i.e., when the motor contactor is dropped out, the terminals 6, 7 of the braking device are connected.
 2. The interlocking contact of the braking device (terminal 8, 9) has to be looped into the control circuit of the motor contactor so that the motor contactor **cannot** pull in during braking.
 3. In the case of braking devices equipped with a separate braking contactor (devices with rated currents from 100A up) the braking contactor and the motor contactor are to be interlocked against each other (electrical interlock with break contact).
-

14.3 Commissioning

Sequence of commissioning:

1. Disconnect the plant from the supply mains
2. Adjust potentiometer "I" to requested braking current (see Chapter 10, Page 11)
3. Switch on the plant
4. Initiate braking by ON and OFF-actuation of the motor contactor

Note: When putting the device into operation for the first time, the braking current should be checked with a true r.m.s. measuring instrument. Clamp-on probes or digital multimeters may only be used if they can measure the true r.m.s..

Adjusting the braking current

The braking current is to be adjusted to a value as small as possible, in order to avoid unnecessary heating of the power semiconductors and the motor. This is especially important in the case of frequent operation. We recommend to limit the maximum braking current to 2.5 times the rated motor current.

The requested braking torque can be adjusted with the potentiometer "I".

If the motor, despite braking with rated device current, does not come to a standstill within the requested time, a braking device of the next higher rating class is to be used.

Note: In the case of devices featuring the option „braking current display“, the braking current is displayed during braking.

Adjusting the braking time

In the case of time-dependent braking, the time in which the braking current flows, can be adjusted with the potentiometers „t1“ and „t2“.

The time should be adjusted so that the braking current is switched off approx. 2s after the motor has come to a standstill.

The adjustments are to be checked and possibly re-adjusted when the motor has normal operating temperature.

Adjusting the standstill threshold

The potentiometer „n0“ can be used if, in the case of standstill-dependent braking, no motor standstill is detected or the braking current is switched off before the motor has come to a standstill.

How to proceed:

1. If no motor standstill is detected, turn the potentiometer slightly clockwise. By carrying out several braking operations a setting is to be found which switches the braking current off approx. 1.5s after the motor has come to a standstill.

2. If the braking current switches off too early, turn the potentiometer slightly counter-clockwise. By carrying out several braking operations a setting is to be found which switches the braking current off approx. 1.5s after the motor has come to a standstill.

**Attention:**

When carrying out several braking operations in succession, the motor can overheat.

Normally, re-adjustments with this potentiometer are not necessary.
Operation manual (please see connection diagram).

15. Dimensioning rules

Note! All data sheets and commissioning instructions are available on our homepage at www.peter-electronic.com.

15.1 Dimensioning of braking contactors

The braking contactor is switched on or off via a control contact of the braking device (no-load switching).

When selecting the braking contactor, it must be ensured that the contacts are able to carry the maximally occurring braking current (nominal/rated device current). Therefore, the value „conventional thermal current“ (I_{th}) is decisive when selecting the braking contactor.

If this value is not indicated, the rated operational current for AC1-operation may be used instead.

Tip: By connecting contacts in parallel it is often possible to use a lower-priced contactor of a smaller design.

15.2 Dimensioning of pre-fuses

Basically, two types of fuse protection are available for the user:

1. Fusing according to allocation type „1“, DIN EN 60947-4-2.
After a short circuit, the braking device is allowed to be inoperative.
2. Fusing according to allocation type „2“, DIN EN 60947-4-2.
After a short circuit, the braking device must be suitable for further use. However, there is the danger that the contacts of the braking relay (braking contactor) weld. Therefore, if possible, these contacts are to be checked prior to reconnecting the device to the supply. If this check cannot be carried out by the user, the device has to be returned to the producer in order to have it checked.

The following dimensioning information refers to the below operating conditions:

- Use of standard asynchronous motors
 - Braking time not exceeding 20s, for braking devices up to 36A.
 - Braking time not exceeding 40s, for braking devices from 40A up.
 - Braking current not exceeding $2.5 \times I_{NOM}$ of the motor.
 - Cyclic duration factor (c.d.f.) not exceeding the value indicated in the data sheet.
-

Fusing according to allocation type „1“:

As pre-fuses, we recommend to use line protection fuses (utilization category gL) or automatic circuit-breakers with tripping characteristic B, C, D or K.

Taking into account the maximum braking currents that occur (normally the nominal/rated device current), we recommend fuses according to table 2, column 3.

Note: Wiring cross-sectional area according to DIN VDE 0100-430,
DIN EN 57100-430.

Fusing according to allocation type „2“:

The power semiconductors are to be protected by fuses of the utilization category gR (semiconductor fuses, high-speed fuses). However, since these fuses do not ensure line protection, it is necessary to use additionally line protection fuses (utilization category gL).

As for the dimensioning of the line protection fuse (gL), please refer to table 2, column 3.

To protect the semiconductors it is necessary to select gR-fuses featuring cutoff- I^2t -values of the ranges indicated in table 2, column 4. In this connection, the current value of the selected fuse should not be smaller than the braking current to be expected (nominal/rated device current).

Note 1: On the basis of the recommended I^2t -value, braking current, and possibly the c.d.f., the fuse supplier is able to select a suitable type. Due to the great variety of producers, sizes and types, PETER electronic does not recommend any particular fuses.

Note 2: If the value of the fuse or cutoff- I^2t -value is selected too small, it may happen that the semiconductor fuse reacts during braking.

Column 1	Column 2	Column 3	Column 4
max. Braking current / Rated device current	Device type	Fuse value allocation type „1“	Recommended range for cutoff- I^2t -value of semiconductor protection fuses allocation type „2“
40A	VB ...-40	32A / 35A	1.400... 3.500 A ² s
60A	VB ...-60	40A	3.000 ... 4.650 A ² s
100A	VB ...-100	63A	6.000 ... 7.600 A ² s
200A	VB ...-200	125A	50.000 ...76.000 A ² s
250A	VB ...-250	160A	50.000 ...76.000 A ² s
400A	VB ...-400	250A	200.000 ... 305.000 A ² s
600A	VB ...-600	400A	600.000 ...1.050.000 A ² s

Table 2

15.3 Permissible braking frequency

The braking frequency depends on the adjusted braking current.

The braking devices of the VB 230/400-40...600A type are designed for a cyclic duration factor (c.d.f.) of 20% and allow the following braking frequencies:

Braking current	Braking time	Braking frequency
rated device current	5s 15s 40s	1 braking per 25s 1 braking per 75s 1 braking per 200s
75% rated device current	5s 15s 40s	1 braking per 20s 1 braking per 60s 1 braking per 150s
50% rated device current	5s 15s 40s	1 braking per 13s 1 braking per 38s 1 braking per 100s

For intermediate values please refer to the load curve (see table 3, page 20).

Table 3

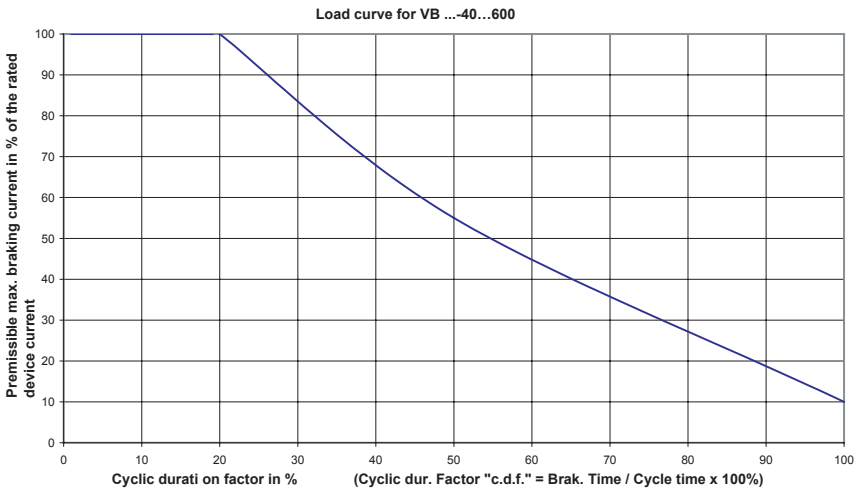

$$\text{Cyclic duration factor (c.d.f.)} = \frac{t_B}{\text{Cycle time}} \cdot 100$$

t_B = Braking time, Cycle time = Braking time + Non-braking time



Attention!

If braking times exceeding 40s are required, it is absolutely necessary to reduce the permissible max. braking current according to the following table.

Non-observance can damage the braking device and motor!

Table 4

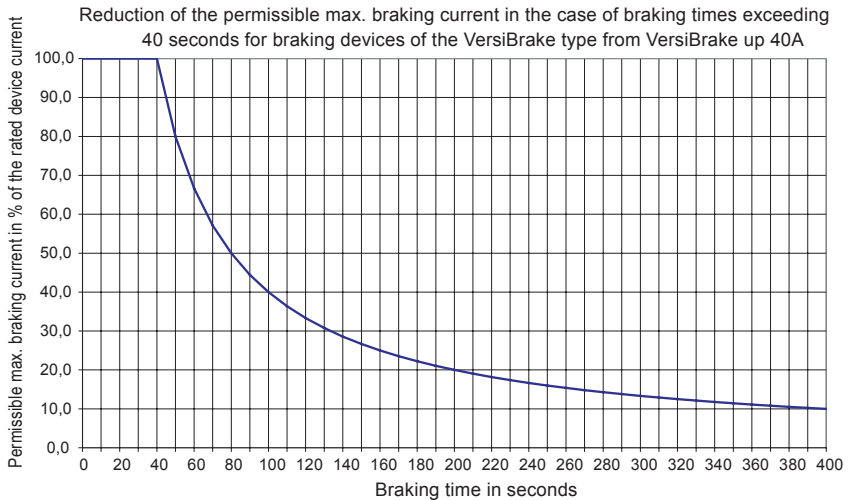

Attention!

When setting up the machine or during commissioning it is possible to carry out 5 braking operations in succession with the rated device current at a braking time of 15s. After these operating conditions, however, the device needs a recovery time of 20 minutes.

16. Dimensions

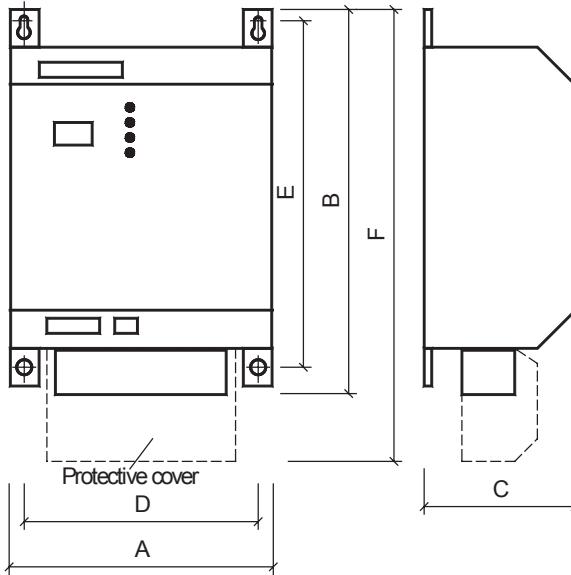

	A	B	C	D	E	F
VB ... - 40	110	242	140	86	226	-
VB ... - 60	110	242	140	86	226	-
VB ... - 100	110	242	140	86	226	-
VB ... - 200/250	110	255	155	80	226	-
VB ... - 400	210	275	165	180	226	340
VB ... - 600	310	280	165	280	226	355

All dimensions in mm.

Layout of power terminals:

VB ... - 40 ... 100	PE	L1	U	L2	V	PE
VB ... - 200/250	PE	L1	U	L2	V	
VB ... - 400	PE	L1/U	L2	V		
VB ... - 600	L1/U	PE	V	L2		

17. Typical connections

17.1 Connection diagram VB 230/400-40...60

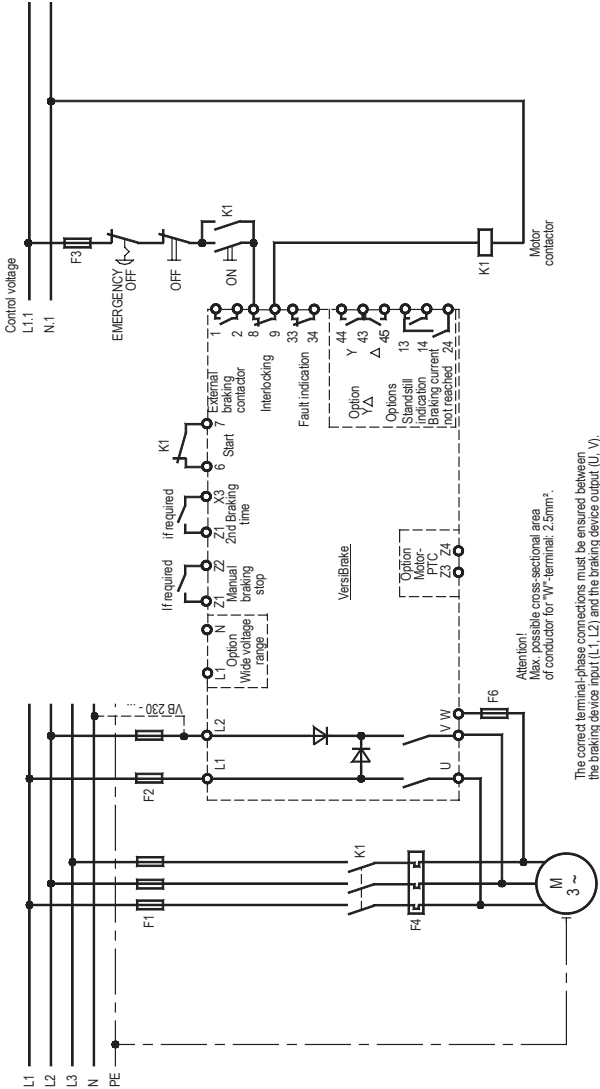

EMC

The limit values for emitted according to the applicable device standards do not rule out the possibility that receivers and susceptible electronic devices within a radius of 10m are subjected to interference. If such interference, which is definitely to the operation of the braking devices "VB", occurs, the emitted interference can be reduced taking appropriate measures. Such measures are, e.g.:
 To connect reactors (3mH) or a suitable mains filter in series before the braking device, or to connect X-capacitors (0.15μ F) in parallel to the supply voltage terminals.

17.2 Connection diagram VB 230/400-100...600

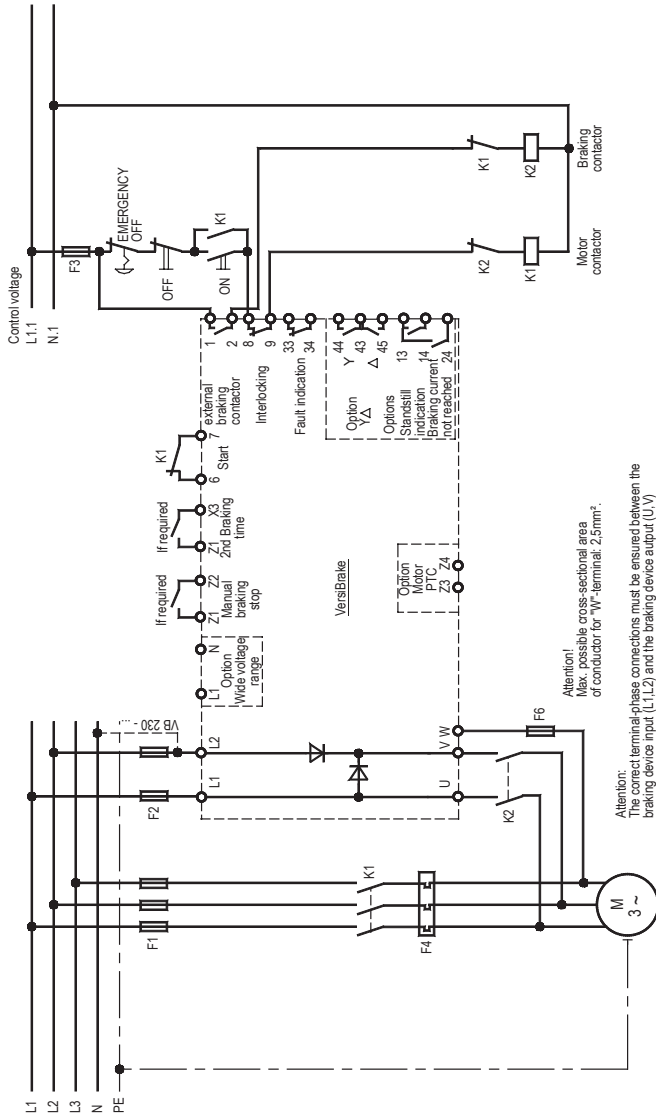

EMC

The limit values for emitted according to the applicable device standards do not rule out the possibility that receivers and susceptible electronic devices within a radius of 10m are subjected to interference. If such interference, which is definitely to the operation of the braking devices "VB", occurs, the emitted interference can be reduced taking appropriate measures. Such measures are, e.g.:
To connect reactors (3mH) or a suitable mains filter in series before the braking device, or to connect X-capacitors (0,15µF) in parallel to the supply voltage terminals.

17.3 Connection diagram with all options VB ...-40...60

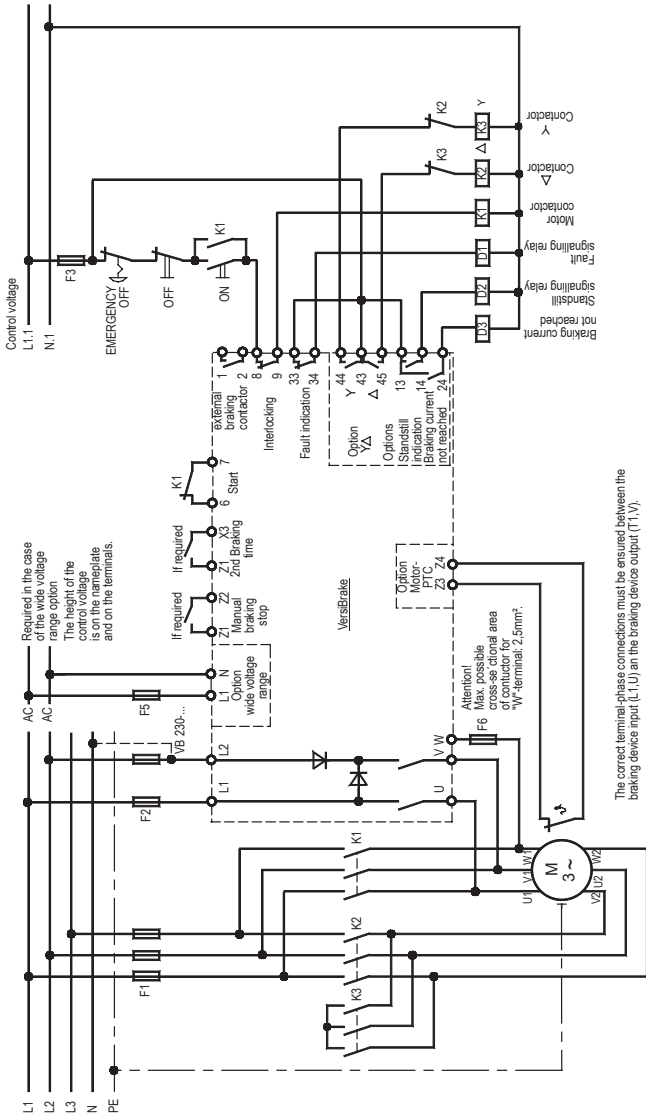

EMC
 The limit values for emitted according to the applicable device standards do not rule out the possibility that receivers and susceptible electronic devices within a radius of 10m are subjected to interference. If such interference, which is definitely to the operation of the braking devices "VB", occurs, the emitted interference can be reduced taking appropriate measures. Such measures are, e.g.:
 To connect reactors (3mH) or a suitable mains filter in series before the braking device, or to connect X-capacitors (0,15µF) in parallel to the supply voltage terminals.

17.4 Connection diagram with all options VB ...100...600

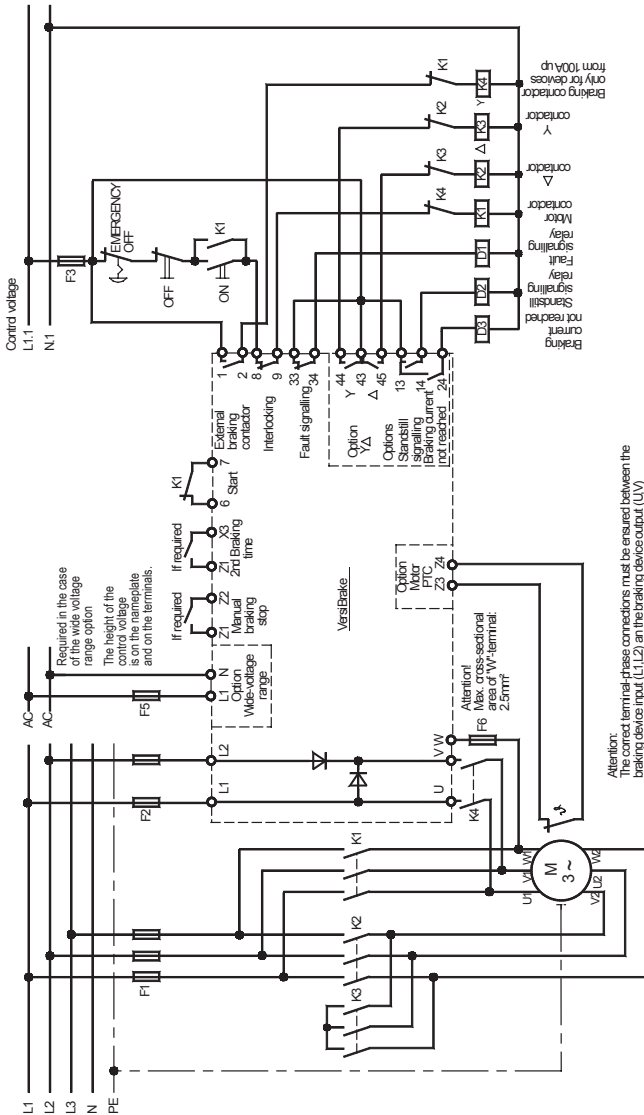

EMC
The limit values for emitted according to the applicable device standards do not rule out the possibility that receivers and susceptible electronic devices within a radius of 10m are subjected to interference. If such interference, which is definitely to the operation of the braking devices "VB", occurs, the emitted interference can be reduced taking appropriate measures. Such measures are, e.g.:
To connect reactors (3mH) or a suitable mains filter in series before the braking device, or to connect X-capacitors (0,15µF) in parallel to the supply voltage terminals.

17.5 Connection diagram for special devices VB 480/690-40...60APBC, 24VAC

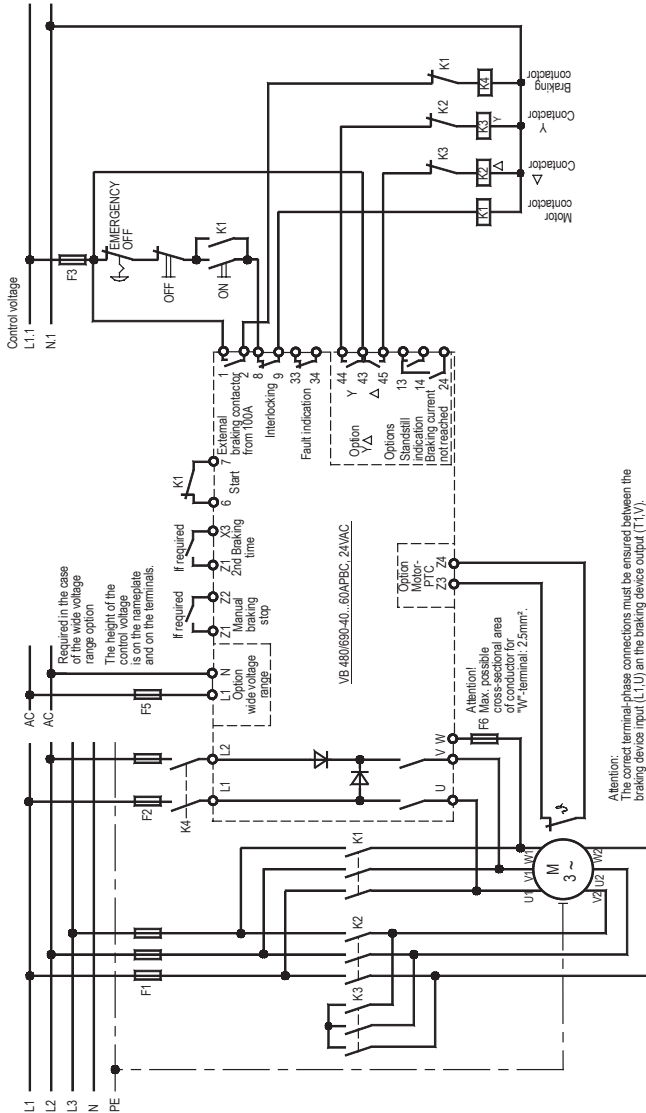

Attention:
The correct terminal-phase connections must be ensured between the braking device input (L1, L2) and the braking device output (T1, T2).

EMC

The limit values for emitted according to the applicable device standards do not rule out the possibility that receivers and susceptible electronic devices within a radius of 10m are subjected to interference. If such interference, which is definitely to the operation of the braking devices "VB", occurs, the emitted interference can be reduced taking appropriate measures. Such measures are, e.g.:
To connect reactors (3mH) or a suitable mains filter in series before the braking device, or to connect X-capacitors (0,15μF) in parallel to the supply voltage terminals.

Time diagram for special devices VB 480/690-40...60APBC, 24VAC

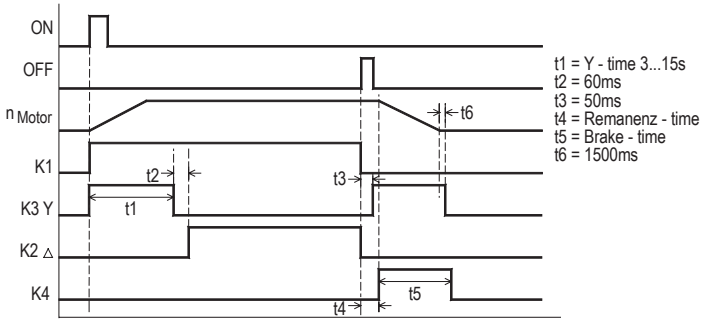

17.6 Connection diagram for special devices VB 480/690-100...600APBC, 24VAC

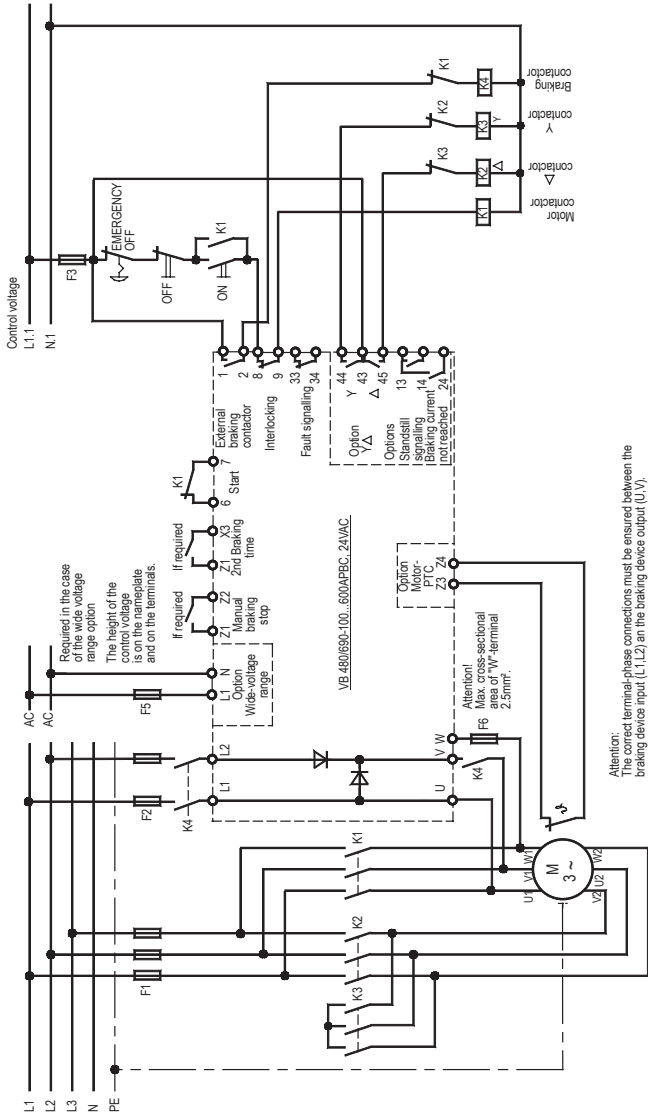

EMC

The limit values for emitted according to the applicable device standards do not rule out the possibility that receivers and susceptible electronic devices within a radius of 10m are subjected to interference. If such interference, which is definitely to the operation of the braking devices "VB", occurs, the emitted interference can be reduced taking appropriate measures. Such measures are, e.g.:
To connect reactors (3mH) or a suitable mains filter in series before the braking device, or to connect X-capacitors (0,15µF) in parallel to the supply voltage terminals.

Time diagram for special devices VB 480/690-100...600APBC, 24VAC

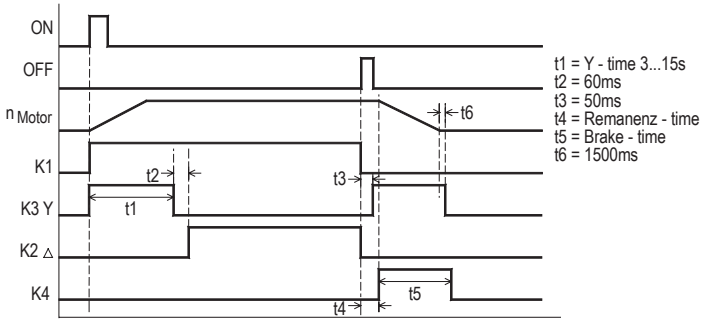



www.peter-electronic.com

