

Softstarters  
Combined Motor Start and Braking Devices (B)  
MINISTART 1.5 ... 11  
Assembly- and Commissioning Instructions

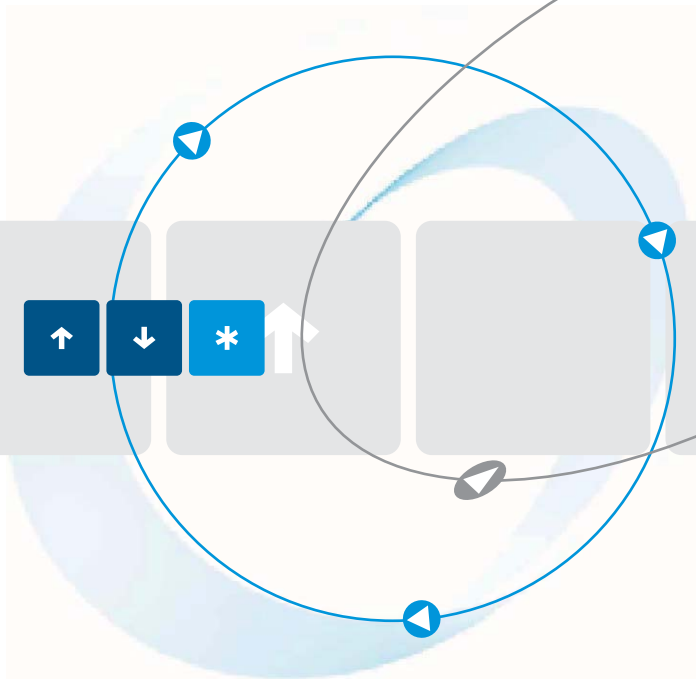

as per 04/10

11200.10002

| <b>Table of Contents</b>                            | <b>Page</b> |
|---|-------------|
| 1. Safety notes                                     | 3           |
| 2. Conformity                                       | 3           |
| 3. General description                              | 4           |
| 4. Usage to the intended purpose                    | 4           |
| 5. EC Declaration of Conformity                     | 5           |
| 6. Block diagram                                    | 6           |
| 7. Functional description                           | 6           |
| 7.1 Monitoring                                      | 6           |
| 7.2 Indicators                                      | 6           |
| 7.3 Braking Option                                  | 7           |
| 8. Commissioning                                    | 7           |
| 8.1 Mounting instructions                           | 7           |
| 8.2 Connection                                      | 9           |
| 8.3 Parameter adjustmenst                           | 10          |
| 9. Operational indications, control outputs         | 12          |
| 9.1 Operational indications                         | 12          |
| 9.2 Control outputs                                 | 12          |
| 10. Fault Indication                                | 13          |
| 11. Technical data                                  | 14          |
| 11.1 Environmental conditions                       | 14          |
| 12. Dimensioning rules                              | 15          |
| 12.1 Dimensioning of pre-fuses                      | 15          |
| 13. Installation guideline                          | 16          |
| 13.1 General connection diagram                     | 17          |
| 13.2 Typical connections                            | 18          |
| 13.3 Typical connection: Reverse circuit option B/S | 19          |
| 14. Dimensions                                      | 20          |

---

These commissioning instructions were prepared with great care. Nevertheless, PETER electronic GmbH & Co. KG does not assume liability for damage resulting from mistakes possibly contained in this manual. Technical changes that serve to improve the product are subject to change without notice.

### Notes and symbols used in these instructions

**Note:** Notes explain the advantages of certain adjustments or settings and help you to make use of the device in the best possible way.



**Warning notices: Read them carefully and follow them strictly!**

Warning notices are indicated in order to protect you against danger or to help you to prevent the device from being damaged.



**Caution: Danger to life through electric shock!**

When you see this sign, always make sure that the device is de-energized and secured against unintentional energizing.

---

## 1. Safety notes



The described devices are electrical equipment for use in industrial electrical power installations. An impermissible removal of the covers during operation can cause serious damage to your health, since these devices contain live parts with high voltages.

Adjustment work may only be performed by trained staff observing the safety regulations. Assembly and mounting work may only be carried out with the equipment deenergized.

Make sure that all drive components are properly earthed.

Please read these commissioning instructions carefully before putting the device into operation.

Besides, the user must ensure that the devices and associated components are fitted and connected in accordance with the applicable local, legal and technical regulations. The VDE-regulations VDE 0100, VDE 0110 (EN 60664), VDE 0160 (EN 50178) , VDE 0113 (EN 60204, EN 61310), VDE 0660 (EN 50274) plus the appropriate regulations of the TÜV (Technical Control Association) and the trade associations apply in Germany.

The user must ensure that the drive turns into a safe operating state following a device failure, in the event of maloperation, or if the control unit has failed etc..

**Caution:** Even if the motor is at rest, it is **not** physically separated from the mains.

## 2. Conformity

In industrial linguistic usage the drive controllers of the type series MINISTART are called "devices", however, in the sense of the "law on the safety of equipment", the "EMC-law" or the "EC-machinery directive" they are not devices or machines ready for use or connection but they are components. It is only possible to define their final function, when these components are integrated into the design and construction of the user.

**To be able to use the devices to their intended purpose, it requires power supply networks according to DIN EN 50160 (IEC38).**

The user takes the responsibility that the user's design and construction comply with the applicable legal provision.

The commissioning is strictly forbidden as long as the conformity of the final product with the guidelines 2006/42/EC (Machinery directive) and 2006/95/EC (Low voltage directive) is not proved.

---

### 3. General description

The electronic soft start and soft stop devices of the MINISTART type not only enable a jolt-free starting of three-phase standard motors but they also limit the current peaks (6-8 fold motor rated current) that result when these motors are switched on.

Consequently, MINISTART is both a reliable and low-cost alternative to the often disadvantageous star-delta connection.

Even under fault conditions the monitoring functions ensure that the circuit reacts in a defined way.

To achieve shorter motor braking times, MINISTART, instead of the soft stop function, can be equipped with an electronic braking attachment.

The compact enclosure enables connections in conformance with the wiring flow and is perfectly suited for an installation on 35mm-top-hat rails in switchgear.

### 4. Usage to the intended purpose

The devices of the DUOSTART-series are electrical equipment that is used in industrial electrical power installations. They are designed for the application in machines, in order to reduce the starting torque or the inrush peaks and the soft stop torque of drives with three-phase motors.

#### Bevorzugte Einsatzbereiche

- pumps, ventilators
  - cranes
  - travelling and rotary operating mechanisms
  - conveying machinery
  - washing machines, linen dryers
-

**5. EC Declaration of Conformity**

**EC Declaration of Conformity** 

The manufacturer / company placing the product on the market  
(authorized representatives of the manufacturer / companies placing the product on the market  
that are established within the Community)

Name / Address: Peter Electronic GmbH & Co.KG  
Bruckäcker 9  
92348 Berg  
Germany

hereby declares that the following product (device, component, unit) in the version as supplied

**Product designation:** **Softstarter**  
Serien / type designation: MINISTART 1,5 ... 11  
Article group: 212...  
Year of manufacture: 1993

complies with the provisions of the following EC-directives:

**2004/108/EG** concerning Electromagnetic compatibility and **2006/95/EG** concerning Electrical equipment designed for use within certain voltage limits

**The following harmonized standards have been applied:**

|                  |   |                    |  |
|------------------|---|--------------------|--|
| EN 60947-1: 2008 | Low-voltage switchgear and controlgear<br>General rules | EN 60947-4-2: 2007 | Low-voltage switchgear and controlgear<br>Contactors and motor-starters -<br>AC semiconductor motor controllers and starters |
|------------------|---|--------------------|--|

This EC Declaration of Conformity is no longer valid, if the products is modified or changed without our agreement.

This declaration is issued under the sole responsibility of the signatory.

Berg, 05.08.2009  
(place, date)

Dr. Thomas Stiller, Managing Director  
(signatory and function of the signatory)

  
(signature)

## 6. Block diagram

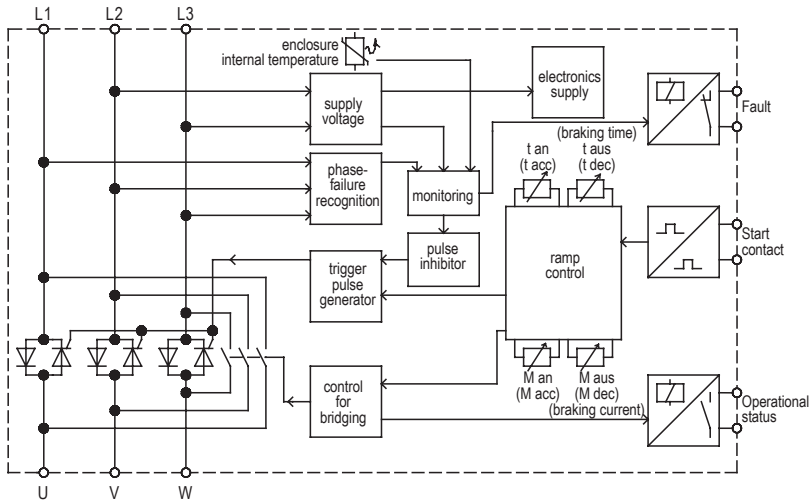

## 7. Functional description

After the adjusted acceleration time, the thyristors are bypassed by integrated relays, so that the motor will again be directly supplied from the mains.

Soft stop is effected in reverse order.

The acceleration time and deceleration time, as well as the breakaway torque and the soft stop torque can be adjusted with a potentiometer each.

The acceleration or deceleration is effected by closing or opening a contact on the input terminals. A potential-free input is available to enable the control by means of an SPC.

### 7.1 Monitoring

The monitoring of the three connected phases, the device temperature and the supply voltages makes sure that in the case of a fault the soft starter will be switched off. In case of a fault, the pulses for the power semiconductors are blocked, the bypass relays drop out and a fault signal is both indicated by an LED and via a potential-free contact it is passed on to the outside where it is further processed.

The fault remains stored until a RESET is effected by shortly disconnecting the device from the supply mains.

### 7.2 Indicators

The essential operating conditions are indicated with four LEDs.

### 7.3 Braking Option

If MINISTART features a braking option, the soft stop function is substituted by d.c. braking. The braking is triggered off by feeding an adjustable direct current into the motor winding.

A one-way rectification, which is formed by a thyristor and a free-wheeling diode, rectifies the voltage gained from the three-phase mains. By changing the trigger point of the thyristor it is possible to infinitely adjust the d.c. voltage and thus the braking torque of the motor. Moreover, the electronics has an installed timer by means of which the braking current is switched off after an adjustable period of time.

If during the braking operation the soft start is switched on again, the braking operation will first be finished.

In case of a fault, excluding phase-failure, the motor will be slowed down with the adjusted values.

Due to the fact that not every switch-off caused by a fault results automatically in braking, a mechanical brake has to be used, if necessary.



**Caution: Danger to life through electric shock!**

Even if the motor is at rest, it is not physically separated from the mains.

## 8. Commissioning

The device is to be put into operation in 3 steps:

1. Mounting
2. Connection and
3. Parameter setting

### 8.1 Mounting instructions



**Caution: Danger to life through electric shock!**

The following conditions are to be complied with in order to ensure a safe and reliable operation of the DUOSTART.

1. The device series DUOSTART is to be used under conditions of the overvoltage category III.
2. Make sure that pollution degree 2 or better, in accordance DIN EN60644-1 / IEC664, is complied with.
3. The device has to be installed into a housing (min. degree of protection: IP54).
4. The device must be operated without being exposed to contamination by water, oil, carbon deposits, dust, etc..

**Note:** The device has to be fitted on a vertical mounting surface, with the control terminals facing downwards. Make sure that no additional heat sources, such as resistors etc. are placed underneath the device.

---

**Warning:**

To avoid heat concentrations, a distance of at least 40mm is to be kept between cable duct and device.

The devices can be mounted directly side by side.

The devices are to be snap-mounted onto a 35mm top-hat rail according to DIN EN 50022. To enable a direct fastening on a mounting plate, two mounting brackets are obtainable.

Proceed as follows to snap on the unit:

- Hold the device at a slight angle (Figure 2)
- Hook the device from above into the top-hat rail
- Apply slight downward pressure to push the device over the top-hat rail and engage it

To remove the device:

- Press the complete device downwards, then tilt it upwards
- Remove the device by lifting it upwards

Figure 2

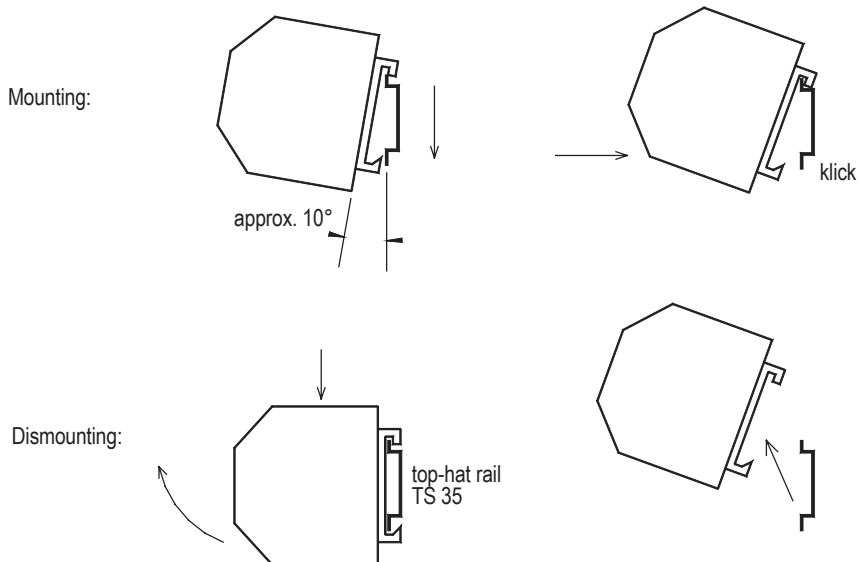

## 8.2 Connection

### power unit (see also connection diagram)

The device is to be installed according to the attached connection diagram. For other connections refer to the factory.

**Note:** Prior to putting the DUOSTART into operation the wiring is to be checked. Only connect the device according to the attached connection diagram.

The mains, motor, and control lines are to run in separate cables. In the case of long cable lengths, the control leads should be laid with shielding. If the drive is to fulfil the radio interference suppression level "N", a filter of the appropriate rating (see "Technical data") is to be integrated in the mains cable as close as possible to the device.

### Power Unit

|                |                               |
|----------------|-------------------------------|
| Terminal L1:   | Mains voltage L1              |
| Terminal L2:   | Mains voltage L2              |
| Terminal L3:   | Mains voltage L3              |
| Terminal U:    | Motor terminal U              |
| Terminal V:    | Motor terminal V              |
| Terminal W:    | Motor terminal W              |
| Flat connector | Protective-conductor terminal |

### Control Unit (12-pole terminal strip)

|              |   |   |  |
|--------------|---|---|--|
| Terminal 1:  | Mains phase                                   | L | with option "external control voltage" |
| Terminal 2:  | No connection                                 |   |  |
| Terminal 3:  | Neutral conductor                             | N | with option "external control voltage" |
| Terminal 4:  | No connection                                 |   |  |
| Terminal 5:  | GND   |   |  |
| Terminal 6:  | Input - control d.c. voltage -                |   |  |
| Terminal 7:  | Input - control d.c. voltage + 10...30V/15mA  |   |  |
| Terminal 8:  | Output 24V/10mA                               |   |  |
| Terminal 9:  | Relay output - make contact "bypass on" or    |   |  |
| Terminal 10: | Relay output - make contact "motor energized" |   |  |
| Terminal 11: | Relay output - break contact "fault"          |   |  |
| Terminal 12: | Relay output - break contact "fault"          |   |  |

### Control via contact

Terminal strip - control unit

Contact for starting or stopping  
Contact loading 24VDC/15mA

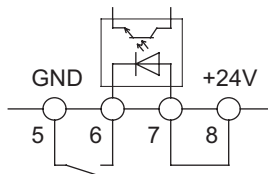

If a contact is closed across terminals 5 and 6, the motor starts with the adjusted ramp-up time. If the contact is opened, the motor runs down with the adjusted ramp-down time, or, with devices featuring the braking option, starts braking..



**Caution: Danger to life through electric shock!**

the terminals 5 and 8 carry mains voltage; therefore the connected contact must be potential-free.

If only soft starting is required, the MINISTART can also be controlled with the main contactor. For this the terminals 5 and 6, as well as the terminals 7 and 8 have to be jumpered.

**Control with control d.c. voltage** (e.g. SPC)

In order to enable the acceleration or deceleration (braking) of the unit by means of an SPC, the MINISTART is equipped with a potential-free d.c. control input.

Terminal strip - Control unit

Control voltage  
e. g., from an SPC  
10...30VDC

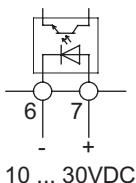

If d.c. voltage is applied to the terminals 6 and 7, the motor will run up with the adjusted acceleration time. If the control voltage is taken away, the motor will run down with the adjusted deceleration time, or, with devices featuring the braking option, starts braking. The terminals 5 and 8 have to remain unassigned.

### 8.3 Parameter adjustment

**Note:** To avoid damage to the device or machine components when making adjustments, it is, prior to the first connection to the mains, recommended to adjust the potentiometers as follows:

**In the case of standard devices:**

|                         |                     |                |
|-------------------------|---------------------|----------------|
| Potentiometer $M_{an}$  | (breakaway torque)  | = left stop    |
| Potentiometer $t_{an}$  | (acceleration time) | = mid position |
| Potentiometer $M_{aus}$ | (Ausschaltmoment)   | = right stop   |
| Potentiometer $t_{aus}$ | (Auslaufzeit)       | = mid position |

**In the case of devices featuring the braking option:**

|                        |                       |                |
|------------------------|-----------------------|----------------|
| Potentiometer $M_{an}$ | (breakaway torque)    | = left stop    |
| Potentiometer $t_{an}$ | (acceleration time)   | = mid position |
| Potentiometer $I_{br}$ | (braking current)     | = left stop    |
| Potentiometer $t_{br}$ | (braking active time) | = mid position |

### Adjusting soft start

1. Switch on the MINISTART and select start-up.
2. Turn potentiometer  $M_{an}$  clockwise so that the motor starts up immediately. Avoid an unnecessary humming when the motor is at rest.
3. Adjust potentiometer  $t_{an}$  until the desired acceleration time or acceleration characteristic is reached.
4. Turn potentiometer  $t_{an}$  counter-clockwise as far as possible! With good acceleration characteristics, this results in short times until the bypass relays pull in, and consequently the power semi-conductors and the motor are less heated. This is particularly important in the case of high loading and switching cycles.



#### Warning

If the ramp-up time is adjusted too short, the internal bypass contact closes before the motor has reached its nominal speed. This can cause damage to the bypass contactor or the bypass relay.

### Adjusting soft stop

**Note:** In order to enable soft stop, the MINISTART, during the soft stop phase, must remain switched on with the three-phase mains.

The potentiometer  $M_{aus}$  must now be turned counter-clockwise until the motor immediately reduces its speed after the soft stop function has been selected. If the load on the motor is small or the soft stop torque is adjusted too high, the motor will continue to run at an almost unchanged speed and only at the end of the adjusted deceleration time will it rapidly reduce its speed.

Now, adjust potentiometer  $t_{aus}$  until the required deceleration time or deceleration characteristic is reached.



#### Caution: Danger to life through electric shock!

Even if the motor is at rest, it is **not** physically separated from the mains.

### Adjusting braking current and braking time (only in devices with braking option)

**Note:** For adjusting the braking current (r.m.s. value) a moving-iron measurement instrument is needed. The instrument has to be inserted into the motor lead U.

Adjust the braking current as small as possible, in order to avoid an unnecessary temperature rise of the power semiconductors and the motor. This is especially important in the case of high switching cycles. We recommend to limit the maximum braking current to double motor rated current.

---

After selecting the braking function, the required braking torque has to be adjusted with the potentiometer "braking current" ( $I_{br}$ ). At the same time the flowing braking-current has to be checked. It is important that the braking current does not exceed the type current of the device. For the corresponding value please refer to the technical data.

With the potentiometer braking time ( $t_{br}$ ), the time, in which the braking current flows, is to be adjusted so that the braking current is switched off shortly after the motor has come to a stop.

The setting is to be re-adjusted when the motor has normal operating temperature.

## 9. Operational indications, control outputs

### 9.1 Operational indications

Four LEDs, which are located underneath a display window, show the operating states of the MINISTART.

|                  |          |   |
|------------------|----------|---|
| LED green        | "SUPPLY" | illuminated = MINISTART ready for operation     |
| LED yellow right | "START"  | illuminated = soft start is selected via input  |
| LED yellow left  | "BYPASS" | illuminated = Power semiconductros are bypassed |
| LED red          | "FAULT"  | illuminated = fault                             |

### 9.2 Control outputs

The MINISTART has two control outputs, the signals are issued via potential-free contact assemblies.

|                   |                              |
|-------------------|------------------------------|
| Contact loading:  | 8A/250VAC per output         |
| Contact material: | silver-Cadmium-oxide (AgCdO) |

#### Terminals 9 and 10 in standard devices:

The contact is closed, when the power semiconductor is bypassed. Not at devices with option „B“.

#### Terminals 9 and 10 closed upon request:

The contact is closed from the beginning of the soft start up to the end of the soft stop or up to the end of the braking process (braking option).

#### Terminals 11 and 12 (fault):

The contact is made when mains voltage is applied and is broken when a fault occurs.

## 10. Fault Indication

A fault is indicated by an illumination of the red LED and an opening of the contact between terminals 11 and 12..

The fault indication is a centralized fault indication.

The following is monitored:

- device temperature
- internal supply voltage
- phase-failure (only during run-up)

If in the case of MINISTART standard devices a fault occurs, the motor will run out uncontrolled. The motor, however, is not disconnected from the mains !

If a fault occurs with MINISTART devices featuring the braking option, the motor will be braked, unless the fault is caused by a phase-failure.

### How to proceed in case of a fault indication:

1. Switch off the mains supply to the MINISTART
2. Eliminate the possible cause of the fault:
  - machine fault (motor is blocked, etc.)
  - phase-failure
  - overheating (check ambient temperature)
  - overheating due to too high thermal stress (too many switching cycles)
3. Switch on the mains supply to the MINISTART (if the fault was caused by overheating, wait until the device has cooled down)

If the fault still exists after the device has been switched on, the mains voltage on the terminals L1, L2, and L3 as well as the internal supply voltage on the terminals 5 and 8 (20...30V/DC) is to be measured.

If you detect that the internal supply voltage is missing, the device has to be sent to the manufacturer.

The fault can only be cleared by a disconnecting the device from the supply mains.



### Caution: Danger to life through electric shock!

The fault **must never** be remedied with the device being switched on !

## 11. Technical data

| Type designation                 | Mains voltage according to DIN EN 50160 (IEC38)                        | max. Motor rating (at 380V) | Rated device current | max. Bra-king current (Type current) | I <sup>2t</sup> Value in A <sup>2</sup> s |
|----------------------------------|--|-----------------------------|----------------------|--------------------------------------|---|
| MINISTART 1.5<br>MINISTART 1.5 B | 400/415V<br>50/60Hz<br>special<br>voltages<br>200-575V<br>upon request | 1.5kW                       | 4A                   | -<br>7A                              | 40  |
| MINISTART 3<br>MINISTART 3 B     |  | 3.0kW                       | 6.5A                 | -<br>14A                             | 450                                       |
| MINISTART 5.5<br>MINISTART 5.5 B |  | 5.5kW                       | 12A                  | -<br>22A                             | 550                                       |
| MINISTART 7.5                    |  | 7.5kW                       | 16A                  | -                                    | 9100                                      |
| MINISTART 11                     |  | 11kW                        | 25A                  | -                                    | 9100                                      |

|  |  |                               |
|--|--|-------------------------------|
| min. Motor load  | 10% of the device power rating   |                               |
| Adjustment range of breakaway torque   | 0...80%  |                               |
| Adjustment range of acceleration time  | 0.5...20s special times upon request   |                               |
| Adjustment range of soft stop torque   | 20...80%   |                               |
| Adjustment range of deceleration time  | 0...20s  |                               |
| Adjustment range of braking current (optional)                                     | approx. 0...2.5 fold motor rated current                                     |                               |
| Adjustment range of braking active time (optional)                                 | 0.75...15s   |                               |
| Repeatability  | 200ms  |                               |
| max. switching cycles (3 x I <sub>NOM</sub> , 10s)<br>No valid at special devices. | MINISTART 1,5...5,5<br>MINISTART 7,5<br>MINISTART 11<br>MINISTART 1,5...5,5B | 120/h<br>60/h<br>20/h<br>90/h |

### 11.1 Environmental conditions

|                       |  |
|-----------------------|--|
| Operating temperature | -25 ... 75°C   |
| Power reduction       | above 45°C - 2% per 1°C up to max. 60°C and altitudes above 1000m -2% per 100m           |
| Storage temperature   | 0 ... 45°C up to an installation altitude of 1000m, not exposed to moisture condensation |
| Degree of protection  | IP 20  |
| Environment           | Overvoltage categ. III (TT / TN-systems), pollution degree 2                             |
| Installation class    | 3  |

## 12. Dimensioning rules

### 12.1 Dimensioning of pre-fuses

Pre-fuses F can be dimensioned according to the following instructions.

Basically, two types of fuse protection are available for the user.

1. Fusing according to allocation type „1“, DIN EN 60947-4-2.  
After a short circuit, the DUOSTART device is allowed to be inoperative and repair work is possible.
2. Fusing according to allocation type „2“, DIN EN 60947-4-2.  
After a short circuit, the device must be suitable for further use. However, there is the danger that the contacts of the bypass or braking relays weld. Therefore, if possible, these contacts are to be checked prior to reconnecting these contacts to the mains supply. If this check cannot be carried out by the user, the device has to be returned to the producer in order to have it checked.

The following dimensioning information refers to the below operating conditions:

- Use of standard asynchronous motors
- Standard acceleration and/or deceleration times
- Switching frequencies not exceeding the values specified in the data sheet

#### Fusing according to allocation type „1“

As pre-fuses we recommend to use line protection fuses (utilization category gL) or automatic circuit-breakers with type K tripping characteristic. In the case of automatic circuit-breakers the tripping characteristic of the type series is to be taken into account. With  $2x I_n$  the tripping time should be at least 20s ( $I_1$ ).

The fuse values are to be determined by taking the conductor cross-sectional area of the wiring into account. Depending on the rated motor current, the maximally occurring starting current (normally up to the 5-fold rated device current) and the starting frequency, the wiring cross-sectional area is to be determined. Table 1 shows the values for numerous applications, i.e., with a 3-fold nominal current as mean starting current and a max. starting time of 10s. In the case of parameter values exceeding these values, it may be necessary to adapt the fuse value accordingly.

**Note:** Wiring cross-sectional area according to DIN VDE 0100-430,  
DIN EN 57100-430.

#### Fusing according to allocation type „2“:

The power semiconductors are to be protected by fuses of the utilization class gR (semiconductor protection fuses, high-speed fuses). However, since these fuses do not ensure line protection, it is necessary to use additionally line protection fuses (utilization category gL).

To protect the semiconductors it is necessary to select gR-fuses featuring cutoff- $I^2t$ -values which are approx. 10-15% below the  $I^2t$ -value of the power semiconductor (see technical data). In this connection, the fuse rating of the selected fuse should not be smaller than the starting current to be expected.

---

**Note:** PETER electronic does not prescribe the use of semiconductor protection fuses. However, for some UL- or CSA-listed devices there are exceptions which are indicated in the relevant commissioning instructions.

**Note 1** On the basis of the  $I^2t$ -value of the power semiconductors, the starting time and possibly the max. starting current, the fuse supplier is able to select a suitable type. Due to the great variety of producers, sizes and types, PETER electronic does not recommend any particular fuses.

**Note 2** If the value of the fuse or the cutoff- $I^2t$ -value is selected too small, it may happen that the semiconductor fuse reacts during the starting phase or during deceleration.

| Rated device current (techn. data) | Device type                      | Fuse value in the case of allocation type 1 | Starting frequencies Starts / h |
|------------------------------------|----------------------------------|---|---------------------------------|
| 4A                                 | MINISTART 1.5<br>MINISTART 1.5 B | 10A   | 120<br>90                       |
| 6,5A                               | MINISTART 3<br>MINISTART 3 B     | 10A   | 120<br>90                       |
| 12A                                | MINISTART 5.5<br>MINISTART 5.5 B | 20A   | 120<br>90                       |
| 16A                                | MINISTART 7,5                    | 25A   | 60                              |
| 25A                                | MINISTART 11                     | 35A/40A                                     | 20                              |

Table 1

### 13. Installation guideline

The device is to be installed according to the attached connection diagram. For other connections please consult PETER electronic GmbH & Co. KG.

The mains, motor, and control lines are to run in separate cables that must be laid separately from each other.

**Note:** Further connection diagrams for special circuit arrangements are available on our homepage at [www.peter-electronic.com](http://www.peter-electronic.com).

**Note:** Prior to putting the MINISTART into operation the wiring is to be checked.

13.1 General connection diagram

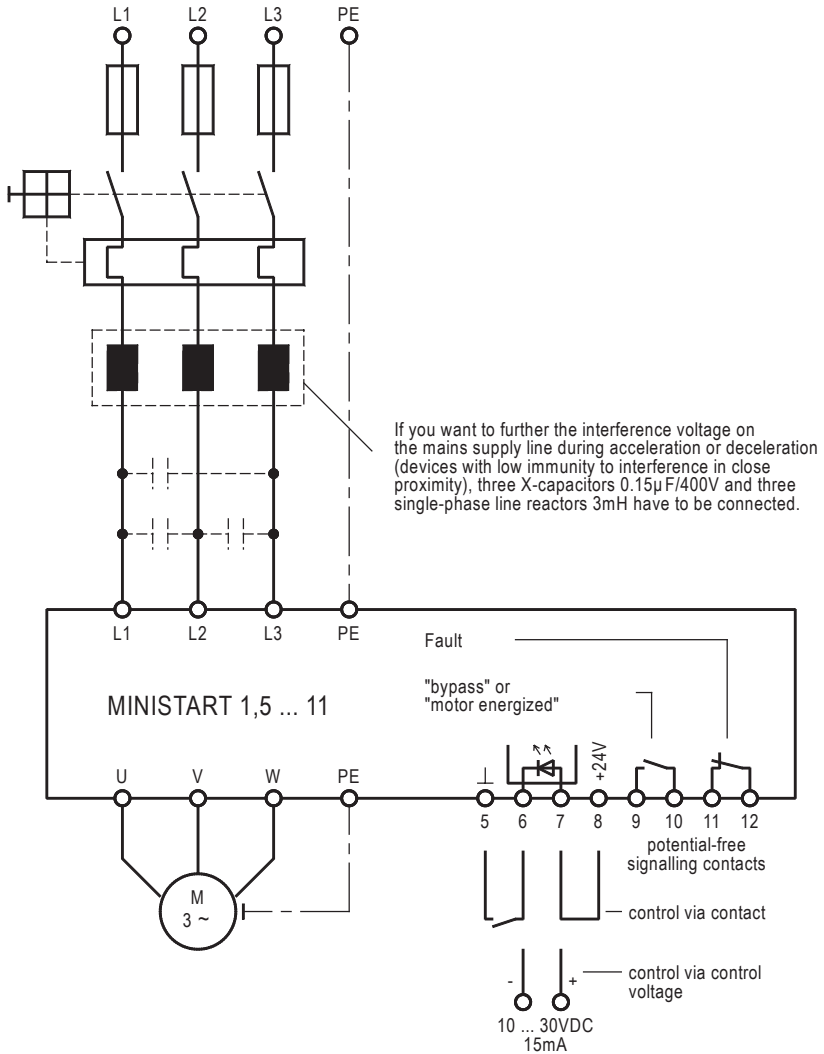

13.2 Typical connections

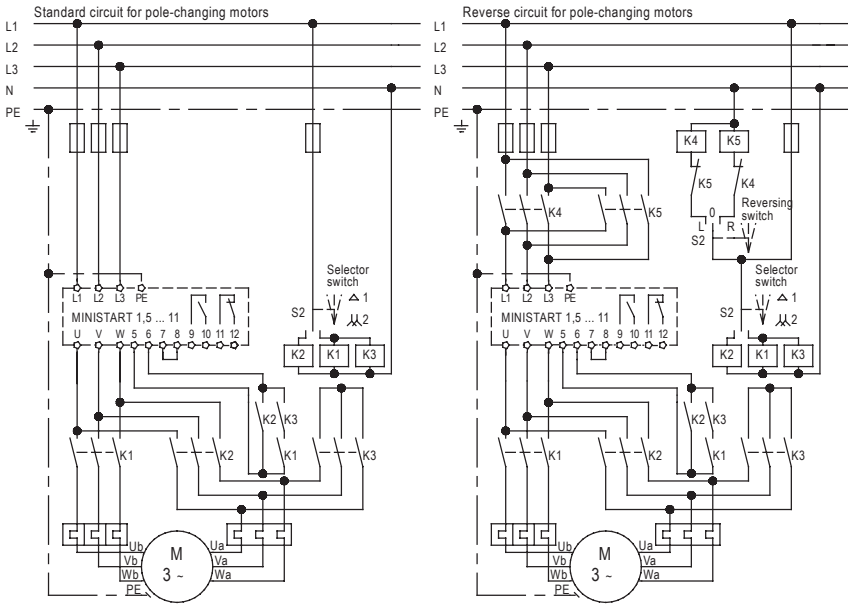
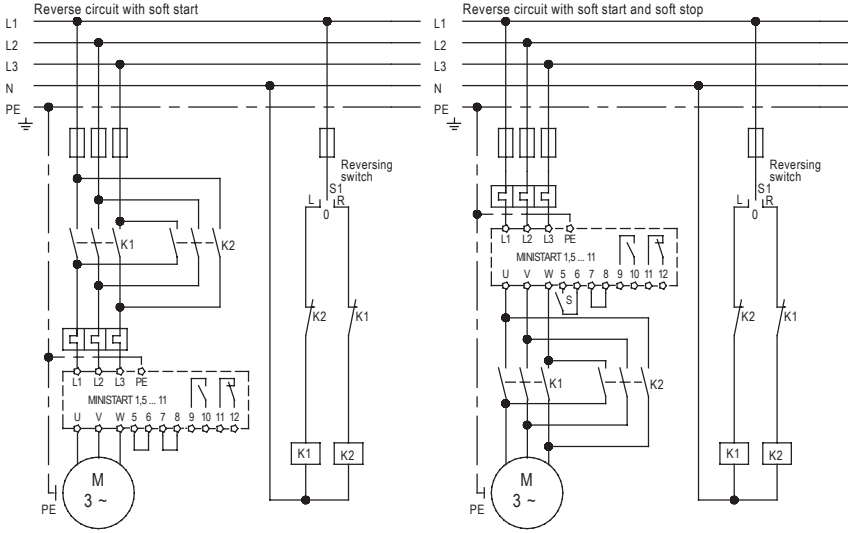

For pole-changing motors trimmer t aus to 0 (left stop)

**13.3 Typical connection: Reverse circuit option B/S**

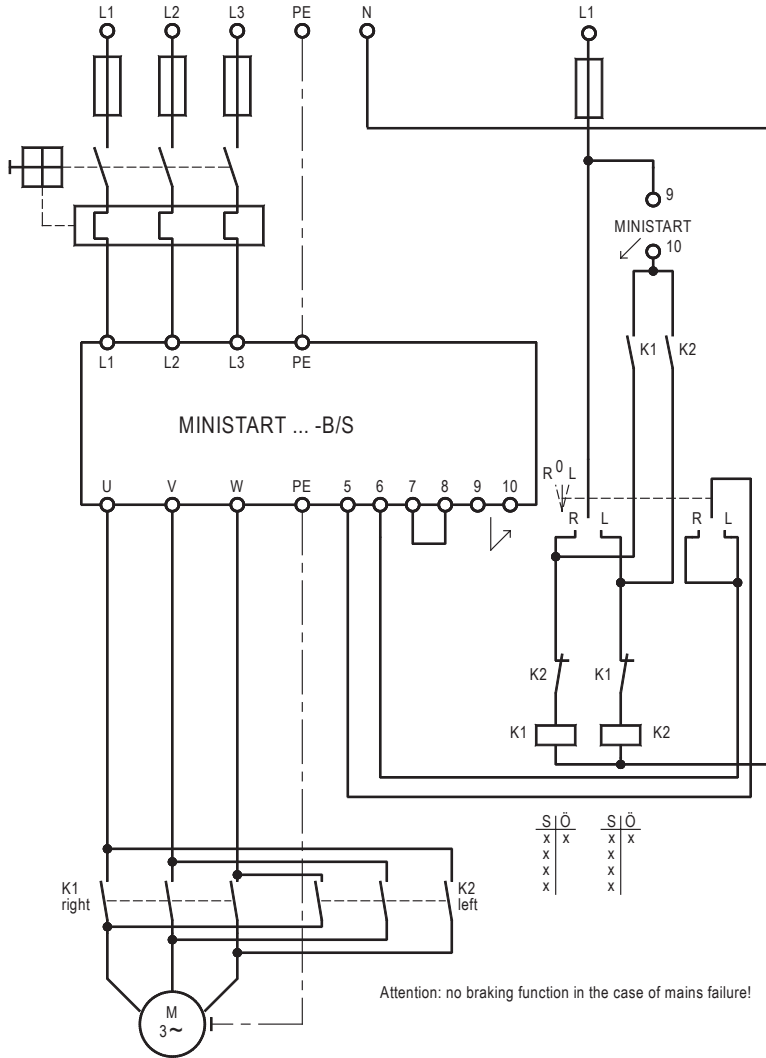

#### 14. Dimensions

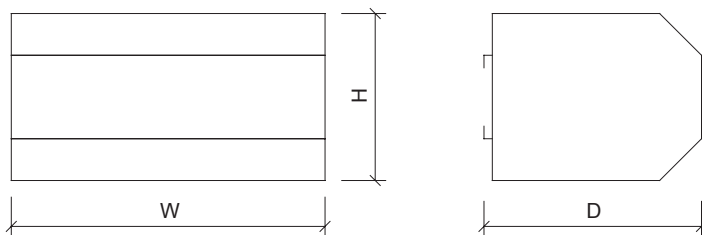

| Mounting dimensions | <b>W</b> | <b>H</b> | <b>D</b> |
|---------------------|----------|----------|----------|
| MINISTART           | 166      | 106      | 117      |

All dimensions indicated in mm.

---



[www.peter-electronic.com](http://www.peter-electronic.com)

