

Softstarter  
MICROSTART 1,5/3  
Assembly- and Commissioning Instructions

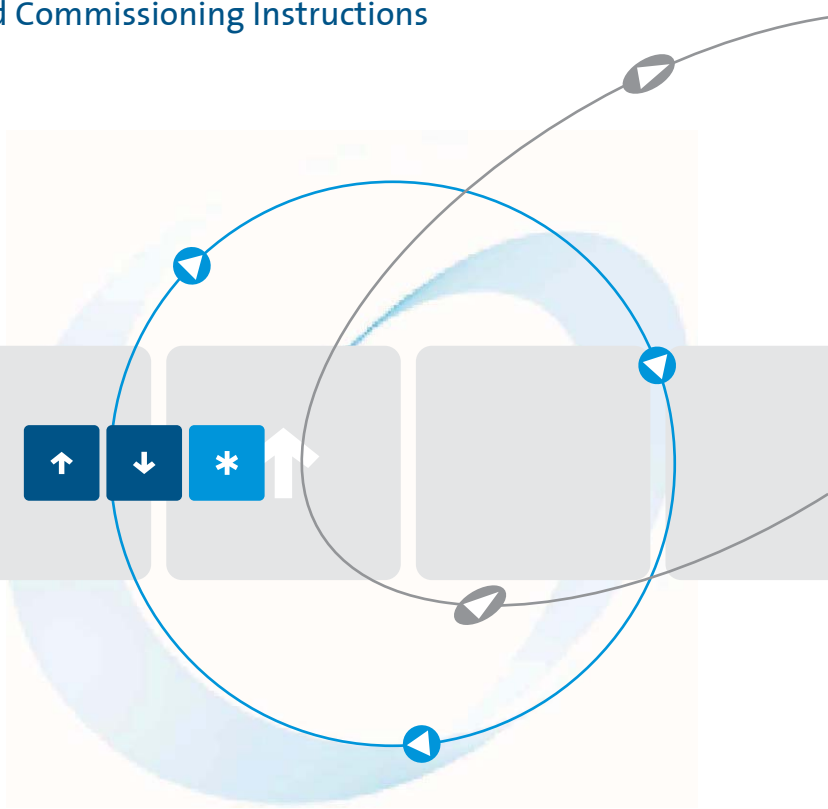

as per 04/10 11300.10001

<b>Table of Contents</b>	<b>Page</b>
1. Safety notes	3
2. Conformity	3
3. General description	4
4. Usage to the intended purpose	4
5. EC Declaration of conformity	5
6. Block diagram	6
7. Commissioning	7
7.1 Mounting instructions	7
7.2 Connection	8
7.3 Parameter adjustments	9
8. Operational indications, Monitoring outputs	10
8.1 Operational indications	10
9. Technical data	11
9.1 Environmental conditions	11
10. Dimensioning rules	12
10.1 Dimensioning of pre-fuses	12
11. Installation guideline	13
11.1 General connection diagram	14
11.2 Typical connections	15
12. Dimensions	16

---

These commissioning instructions were prepared with great care. Nevertheless, PETER electronic GmbH & Co. KG does not assume liability for damage resulting from mistakes possibly contained in this manual. Technical changes that serve to improve the product are subject to change without notice.

### Notes and symbols used in these instructions

**Note:** Notes explain the advantages of certain adjustments or settings and help you to make use of the device in the best possible way.



**Warning notices: Read them carefully and follow them strictly!**

Warning notices are indicated in order to protect you against danger or to help you to prevent the device from being damaged.



**Caution: Danger to life through electric shock!**

When you see this sign, always make sure that the device is de-energized and secured against unintentional energizing.

---

## 1. Safety notes



The described devices are electrical equipment for use in industrial electrical power installations. An impermissible removal of the covers during operation can cause serious damage to your health, since these devices contain live parts with high voltages.

Adjustment work may only be performed by trained staff observing the safety regulations. Assembly and mounting work may only be carried out with the equipment deenergized.

Make sure that all drive components are properly earthed.

Please read these commissioning instructions carefully before putting the device into operation.

Besides, the user must ensure that the devices and associated components are fitted and connected in accordance with the applicable local, legal and technical regulations. The VDE-regulations VDE 0100, VDE 0110 (EN 60664), VDE 0160 (EN 50178) , VDE 0113 (EN 60204, EN 61310), VDE 0660 (EN 50274) plus the appropriate regulations of the TÜV (Technical Control Association) and the trade associations apply in Germany.

The user must ensure that the drive turns into a safe operating state following a device failure, in the event of maloperation, or if the control unit has failed etc..

**Caution:** Even if the motor is at rest, it is **not** physically separated from the mains.

## 2. Conformity

In industrial linguistic usage the drive controllers of the type series MICROSTART are called "devices", however, in the sense of the "law on the safety of equipment", the "EMC-law" or the "EC-machinery directive" they are not devices or machines ready for use or connection but they are components. It is only possible to define their final function, when these components are integrated into the design and construction of the user.

**To be able to use the devices to their intended purpose, it requires power supply networks according to DIN EN 50160 (IEC38).**

The user takes the responsibility that the user's design and construction comply with the applicable legal provision.

The commissioning is strictly forbidden as long as the conformity of the final product with the guidelines 2006/42/EC (Machinery directive) and 2006/95/EC (Low voltage directive) is not proved.

---

### 3. General description

With soft starters of the MICROSTART-type, the motor current is influenced in all phases of the three-phase mains. The trigger angle of the power semiconductor (thyristor) inserted in each phase is generated with integrated circuits and controlled in a way so that first a small and then a continuously increasing current flows. During this adjusted acceleration time the motor torque increases from an adjustable value up to the required maximum torque. Thus, soft and safe starting is ensured even in the case of motors having a high breakaway torque.

After the adjusted acceleration time, the thyristors will be bypassed by integrated relays, so that the motor is again directly supplied from the mains.

Soft stop is effected in reverse order.

Like the starting torque and the stopping torque, the acceleration time and the deceleration time can be adjusted with a potentiometer each.

Acceleration or deceleration is effected by closing or opening a contact on the input terminals.

### 4. Usage to the intended purpose

The devices of the MICROSTART-series are electrical equipment that is used in industrial electrical power installations. They are designed for application in machines, in order to reduce the starting torque and starting current peaks as well as the tripping torque of drives with three-phase induction motors.

#### Typical Applications:

- pumps, ventilators
  - belt drives, driving pulleys / coil winders
  - conveying machinery
  - compressors
-

**5. EC Declaration of conformity**

**EC Declaration of Conformity** 

The manufacturer / company placing the product on the market  
(authorized representatives of the manufacturer / companies placing the product on the market  
that are established within the Community)

Name / Address: Peter Electronic GmbH & Co.KG  
Bruckäcker 9  
92348 Berg  
Germany

hereby declares that the following product (device, component, unit) in the version as supplied

<b>Product designation:</b>	<b>Softstarter</b>
Serien / type designation:	MICROSTART 1.5 / 3
Article group:	213...
Year of manufacture:	1994

complies with the provisions of the following EC-directives:

<b>2004/108/EG</b> concerning Electromagnetic compatibility	and <b>2006/95/EG</b> concerning Electrical equipment designed for use within certain voltage limits
--	--

**The following harmonized standards have been applied:**

EN 60947-1: Low-voltage switchgear and 2008 controlgear General rules	EN 60947-4-2: Low-voltage switchgear and 2007 controlgear Contactors and motor-starters - AC semiconductor motor controllers and starters
---	---

This EC Declaration of Conformity is no longer valid, if the products is modified or changed  
without our agreement.

This declaration is issued under the sole responsibility of the signatory.

Berg, 05.08.2009  
(place, date)

Dr. Thomas Stiller, Managing Director  
(signatory and function of the signatory)

  
(signature)

## 6. Block diagram

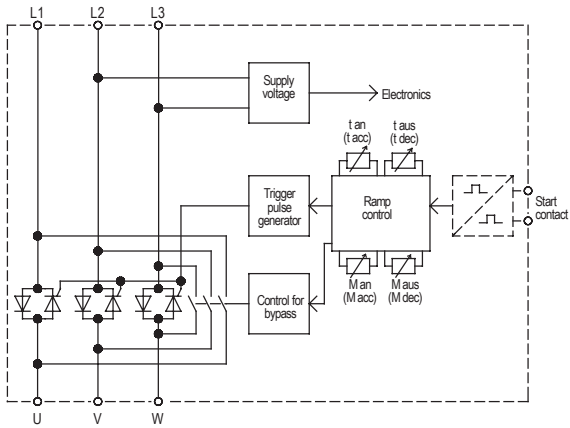

## 7. Commissioning

The device is to be put into operation in 3 steps:

1. Mounting
2. Connection and
3. Parameter setting

### 7.1 Mounting instructions



**Caution: Danger to life through electric shock!**

The following conditions are to be complied with in order to ensure a safe and reliable operation of the MICROSTART.

1. The MICROSTART is to be used under overvoltage conditions of the category III.
2. Make sure that pollution degree 2 or better, in accordance with IEC664, is complied with.
3. The device is to be installed into a housing (min. degree of protection: IP54).
4. The soft starter must be operated without being exposed to contamination by water, oil, carbon deposits, dust, etc..

**Note:** The device has to be fitted on a vertical mounting surface, with the control terminals facing downwards. Make sure that no additional heat sources, such as resistors etc. are placed underneath the device.



**Warning:**

To avoid heat concentrations, a distance of at least 40mm is to be kept between cable duct and device.

The devices can be mounted directly side by side.

The devices are to be snap-mounted onto a 35mm top-hat rail according to DIN EN 50022. To enable a direct fastening on a mounting plate, two mounting brackets are obtainable.

---

Proceed as follows to snap on the unit (Figure 1):

- Hold the device at a slight angle
- Hook the device from above into the top-hat rail
- Apply slight downward pressure to push the device over the top-hat rail and engage it

To remove the device (Figure 2):

- Press the complete device downwards, then tilt it upwards
- Remove the device by lifting it upwards

Figure 1

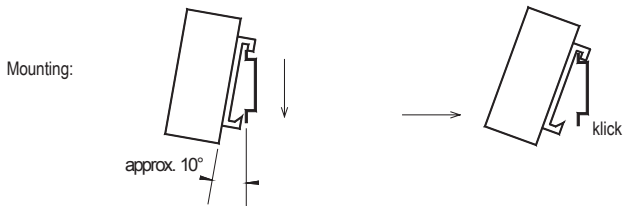
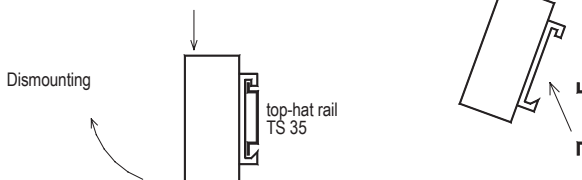

Figure 2



## 7.2 Connection

### power unit (see also terminal diagram)

Terminal L1:	Mains voltage L1
Terminal L2:	Mains voltage L2
Terminal L3:	Mains voltage L3
Terminal U:	Motor terminal U
Terminal V:	Motor terminal V
Terminal W:	Motor terminal W
Terminal PE (Flat connector)	Protective-conductor terminal

**Control unit**

Terminal 1:	Mains phase	L	Control contact
Terminal 2:	No connection		
Terminal 3:	Neutral conductor	N	Control contact

**Control via contact**

Control terminals

Contact for starting or stopping  
Contact loading 12VDC/15mA

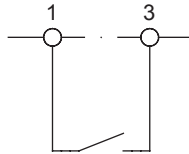

If a contact is closed across terminals 1 and 3, the motor starts with the adjusted ramp-up time. If the contact is open, the motor runs down with the adjusted ramp-down time. The motor, however, is not disconnected from the mains.



**Caution: Danger to life through electric shock!**

The terminals 1 and 3 carry mains potential; therefore, the connected contact must be potential-free.

If only starting is required, the MICROSTART can also be controlled via the main contactor. For this the terminals 1 and 3 have to be jumpered.

**7.3 Parameter adjustments**

**Note:** To avoid damage to the device or machine components when making adjustments, it is, prior to the first connection to the mains, recommended to adjust the potentiometers as follows:

**With standard devices**

Potentiometer $M_{an}$	(brakeaway torque)	= left stop
Potentiometer $t_{an}$	(acceleration time)	= centre position
Potentiometer $M_{aus}$	(soft stop torque)	= right stop
Potentiometer $t_{aus}$	(deceleration time)	= centre position

### Adjusting soft start

1. Switch on the MICROSTART and select soft start.
2. Turn the potentiometer  $M_{acc}$  clockwise so far that the motor starts up immediately. Avoid unnecessary humming when the motor is at rest.
3. Adjust the potentiometer  $t_{acc}$  until the required acceleration time or acceleration characteristic is reached.
4. Turn potentiometer  $t_{acc}$  counter-clockwise as far as possible!

While ensuring good acceleration characteristics, this results in short times until the bypass contactor is energized, and consequently the power semiconductors and the motor are less heated. This is particularly important in the case of high loading and many switching cycles.



#### Warning

If the ramp-up time is adjusted too short, the internal bypass contact closes before the motor has reached its nominal speed. This can cause damage to the bypass contactor or the bypass relay.

### Adjusting soft stop

**Note:** In order to enable soft stop, the MICROSTART, during the deceleration phase, must remain switched on with the three-phase mains.

The potentiometer Maus must now be turned counter-clockwise until the motor immediately reduces its speed after the soft stop function has been selected. If the load on the motor is low and the soft stop torque is adjusted too high, the motor will continue to run at an almost unchanged speed and only at the end of the adjusted deceleration time will it rapidly reduce its speed.

Now, adjust potentiometer  $\tau_{aus}$  until the required deceleration time or deceleration characteristic is reached.



#### Caution: Danger to life through electric shock!

Even if the motor is at rest, it is **not** physically separated from the mains.

## 8. Operational indications, Monitoring outputs

### 8.1 Operational indications

2 LEDs indicating the following operating states are located on the control board.

LED green	illuminated = device connected to mains voltage
LED yellow	illuminated = top of ramp

## 9. Technical data

Type designation	Mains voltage acc. to DIN EN 50160 (IEC 38)	max. Motor rating (at 380V)	Rated device current	I <sup>2</sup> t Value in A <sup>2</sup> s
MICROSTART 1.5	400/415V 50/60Hz	1,5kW	4A	40
MICROSTART 3	special voltage 220/240V 50/60Hz	3,0kW	6,5A	450

Min. Motor load	10% of the device power rating	
Adjustment range of breakaway torque M <sub>an</sub>	0...80%	
Adjustment range of acceleration time t <sub>an</sub>	1...15s (special times upon request)	
Adjustment range of soft stop torque M <sub>aus</sub>	20...80%	
Adjustment range of deceleration time t <sub>aus</sub>	0...15s	
Repeatability	200ms	
max. Switching cycle (3 x I <sub>NENN</sub> , 10s)	MICROSTART 1,5	120/h
	MICROSTART 3	60/h

### 9.1 Environmental conditions

Environmental conditions	-25 ... 75°C
Ambient temperature	0 ... 45°C up to an installation altitude of 1000m, not exposed to moisture condensation
Power reduction	above 45°C - 2% per 1°C up to max. 60°C and altitudes above 1000m -2% per 100m
Degree of protection	IP 20
Environment	Overvoltage categ. III (TT / TN-systems), pollution degree 2
Installation class	3

## 10. Dimensioning rules

### 10.1 Dimensioning of pre-fuses

Pre-fuses F can be dimensioned according to the following instructions.

Basically, two types of fuse protection are available for the user.

1. Fusing according to allocation type „1“, DIN EN 60947-4-2.  
After a short circuit, the MICROSTART device is allowed to be inoperative and repair work is possible.
2. Fusing according to allocation type „2“, DIN EN 60947-4-2.  
After a short circuit, the device must be suitable for further use. However, there is the danger that the contacts of the bypass or braking relays weld. Therefore, if possible, these contacts are to be checked prior to reconnecting these contacts to the mains supply. If this check cannot be carried out by the user, the device has to be returned to the producer in order to have it checked.

The following dimensioning information refers to the below operating conditions:

- Use of standard asynchronous motors
- Standard acceleration and/or deceleration times
- Switching frequencies not exceeding the values specified in the data sheet

#### Fusing according to allocation type „1“

As pre-fuses we recommend to use line protection fuses (utilization category gL) or automatic circuit-breakers with type K tripping characteristic. In the case of automatic circuit-breakers the tripping characteristic of the type series is to be taken into account. With  $2x I_n$  the tripping time should be at least 20s ( $I_1$ ).

The fuse values are to be determined by taking the conductor cross-sectional area of the wiring into account. Depending on the rated motor current, the maximally occurring starting current (normally up to the 5-fold rated device current) and the starting frequency, the wiring cross-sectional area is to be determined. Table 1 shows the values for numerous applications, i.e., with a 3-fold nominal current as mean starting current and a max. starting time of 10s. In the case of parameter values exceeding these values, it may be necessary to adapt the fuse value accordingly.

**Note:** Wiring cross-sectional area according to DIN VDE 0100-430,  
DIN EN 57100-430..

Rated device current (techn. data)	Device type	Fuse value in the case of allocation type 1	Starting frequencies Starts / h ( $3 \times I_{Nenn}$ , 10s)
4A	MICROSTART 1.5	10A	120
6,5A	MICROSTART 3	10A	60

Table 1

**Fusing according to allocation type „2“:**

The power semiconductors are to be protected by fuses of the utilization class gR (semiconductor protection fuses, high-speed fuses). However, since these fuses do not ensure line protection, it is necessary to use additionally line protection fuses (utilization category gL).

To protect the semiconductors it is necessary to select gR-fuses featuring cutoff- $I^2t$ -values which are approx. 10-15% below the  $I^2t$ -value of the power semiconductor (see technical data). In this connection, the fuse rating of the selected fuse should not be smaller than the starting current to be expected.

**Note:** PETER electronic does not prescribe the use of semiconductor protection fuses. However, for some UL- or CSA-listed devices there are exceptions which are indicated in the relevant commissioning instructions.

**Note 1** On the basis of the  $I^2t$ -value of the power semiconductors, the starting time and possibly the max. starting current, the fuse supplier is able to select a suitable type. Due to the great variety of producers, sizes and types, PETER electronic does not recommend any particular fuses.

**Note 2** If the value of the fuse or the cutoff- $I^2t$ -value is selected too small, it may happen that the semiconductor fuse reacts during the starting phase or during deceleration.

**11. Installation guideline**

The device is to be installed according to the attached connection diagram. For other connections refer to the factory.

**Note:** Prior to putting the MICROSTART into operation the wiring is to be checked. Only connect the device according to the attached connection diagram.

The mains, motor, and control lines are to run in separate cables. In the case of long cable lengths, the control leads should be laid with shielding. If the drive is to fulfil the radio interference suppression level "N", a filter of the appropriate rating (see "Technical data") is to be integrated in the mains cable as close as possible to the device.

---

## 11.1 General connection diagram

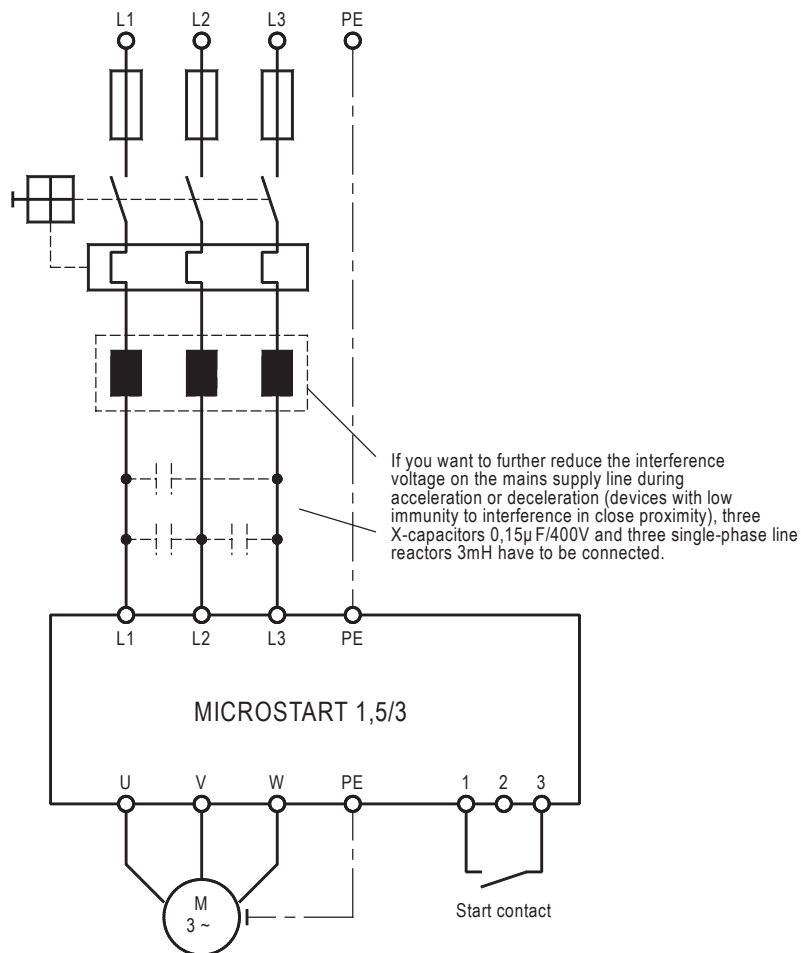

**11.2 Typical connections**

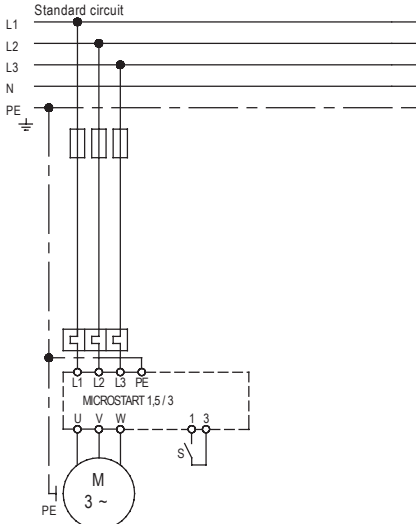

S - closed = soft start; S - open = soft stop

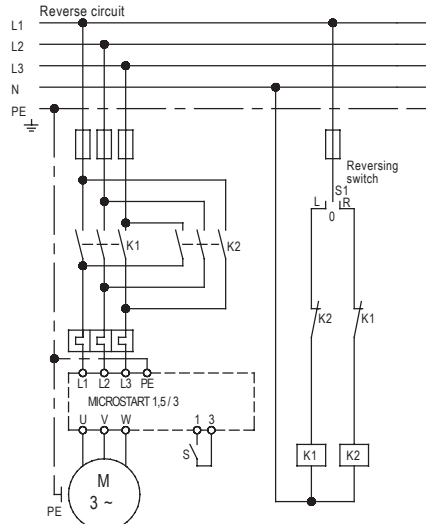

S - closed = soft start; S - open = soft stop

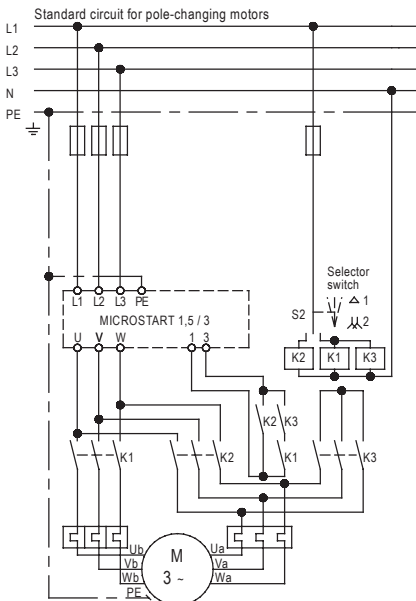

For pole-changing motors trimmer t aus to 0 (left stop)

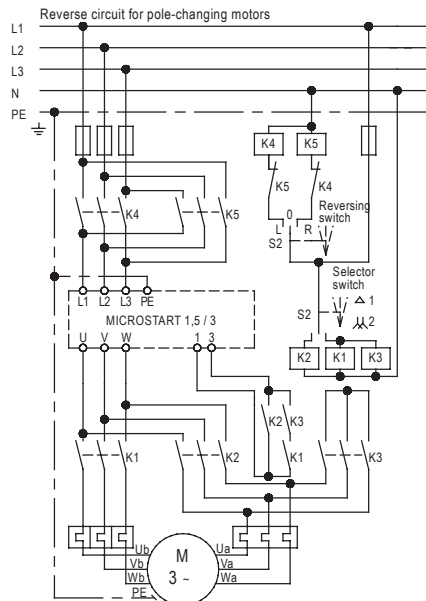

## 12. Dimensions

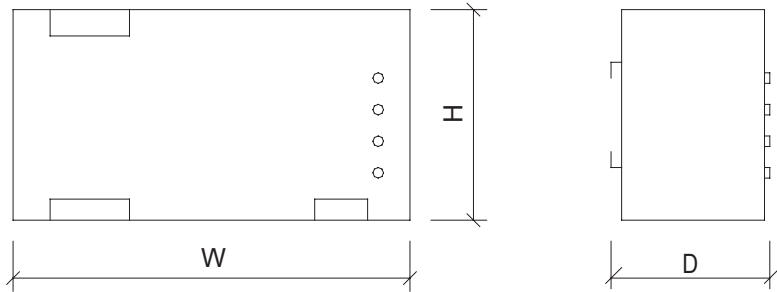

Mounting dimensions	W	H	D
MICROSTART	166	106	55

All dimensions indicated in mm.



[www.peter-electronic.com](http://www.peter-electronic.com)

