



## **STARTING GUIDE** ***FRENIC MEGA***

### High Performance Multifunction Inverter

3 ph 400 V 0.4 to 75 kW  
3 ph 200 V 0.4 to 55 kW

<b>Index</b>	<b>Version</b>	<b>Date</b>	<b>Applied by</b>
0.4.0	Version for proofreading	16.11.07	Andreas Schader,
0.5.0	European Version	06.02.08	Andreas Schader
0.6.0	Second proofreading	19.02.08	Andreas Schader
0.7.0	Information added and some corrections made, reduced version made	26.05.08	David Bedford
1.0	Version approved	26.06.08	David Bedford

# MEGA

## CONTENTS

Chapter	Page
1. SAFETY INFORMATION AND CONFORMITY TO STANDARDS	1
2. MECHANICAL INSTALLATION	4
3. WIRING	6
4. OPERATION USING THE KEYPAD	17
5. QUICK START COMMISSION	19
6. FUNCTION CODES	25
7. TROUBLESHOOTING	33
8. SPECIFICATIONS AND EXTERNAL DIMENSIONS	34
9. OPTIONS	36

Thank you for purchasing our FRENIC-Mega series of inverters.

This product is designed to drive three-phase induction motors for many types of application. Read through this manual and be familiar with correct handling and operation of this product. Improper handling may result in an incorrect operation, a short life, or even a failure of this product as well as the motor.

Deliver this manual to the end user of this product. Keep this manual in a safe place until this product is discarded.

Listed below there are the other materials related to the use of the FRENIC-Mega. Read them in conjunction with this manual if necessary.

- FRENIC-Mega User's Manual (MEH278)
- FRENIC-Mega Instruction Manual (INR-SI47-1223a-E)
- RS-485 Communication User's Manual (MEH448b)
- FRENIC-Mega Catalogue (MEH642a)



The materials are subjected to change without notice. Be sure to obtain the latest editions for use.

## Chapter 1 SAFETY INFORMATION AND CONFORMITY TO STANDARDS

### 1.1 Safety precautions

Read this manual thoroughly before proceeding with installation, connections (wiring), operation, or maintenance and inspection. Ensure you have sound knowledge of the device and familiarize yourself with all safety information and precautions before proceeding to operate the inverter.

Safety precautions are classified into the following two categories in this manual.

 <b>WARNING</b>	Failure to heed the information indicated by this symbol may lead to dangerous conditions, possibly resulting in death or serious bodily injuries.
 <b>CAUTION</b>	Failure to heed the information indicated by this symbol may lead to dangerous conditions, possibly resulting in minor or light bodily injuries and/or substantial property damage.

Failure to heed the information contained under the CAUTION title can also result in serious consequences. These safety precautions are of utmost importance and must be observed at all times.

#### Application

 <b>WARNING</b>
<ul style="list-style-type: none"> <li>The FRENIC-Mega is designed to drive a three-phase induction motor. Do not use it for single-phase motors or for other purposes. <b>Fire or an accident could occur.</b></li> <li>The FRENIC-Mega may not be used for a life-support system or other purposes directly related to the human safety.</li> <li>Though the FRENIC-Mega is manufactured under strict quality control, install safety devices for applications where serious accidents or property damages are foreseen in relation to the failure of it. <b>An accident could occur.</b></li> </ul>



#### Installation

 <b>WARNING</b>
<ul style="list-style-type: none"> <li>Install the inverter on a base made of metal or other non-flammable material. <b>Otherwise, a fire could occur.</b></li> <li>Do not place flammable object nearby. <b>Doing so could cause fire.</b></li> <li>Inverters with a capacity of 30 kW or above, whose protective structure is IP00, involve a possibility that a human body may touch the live conductors of the main circuit terminal block. Inverters to which an optional DC reactor is connected also involve the same. Install such inverters in an inaccessible place. <b>Otherwise, electric shock or injuries could occur.</b></li> </ul>

 <b>CAUTION</b>
<ul style="list-style-type: none"> <li>Do not support the inverter by its front cover during transportation. <b>Doing so could cause a drop of the inverter and injuries.</b></li> <li>Prevent lint, paper fibers, sawdust, dust, metallic chips, or other foreign materials from getting into the inverter or from accumulating on the heat sink.</li> <li>When changing the positions of the top and bottom mounting bases, use only the specified screws. <b>Otherwise, a fire or an accident might result.</b></li> <li>Do not install or operate an inverter that is damaged or lacking parts. <b>Doing so could cause fire, an accident or injuries.</b></li> </ul>

#### Wiring

 <b>WARNING</b>
<ul style="list-style-type: none"> <li>If no zero-phase current (earth leakage current) detective device such as a ground-fault relay is installed in the upstream power supply line in order to avoid the entire power supply system's shutdown undesirable to factory operation, install a residual-current-operated protective device (RCD)/earth leakage circuit breaker (ELCB) individually to inverters to break the individual inverter power supply lines only. <b>Otherwise, a fire could occur.</b></li> <li>When wiring the inverter to the power source, insert a recommended molded case circuit breaker (MCCB) or residual-current-operated protective device (RCD)/earth leakage circuit breaker (ELCB) (with overcurrent protection) in the path of each pair of power lines to inverters. Use the recommended devices within the recommended current capacity.</li> <li>Use wires in the specified size.</li> <li>Tighten terminals with specified torque. <b>Otherwise, a fire could occur.</b></li> </ul>

 <b>WARNING</b>
<ul style="list-style-type: none"> <li>When there is more than one combination of an inverter and motor, do not use a multicore cable for the purpose of handling their wirings together.</li> <li>Do not connect a surge killer to the inverter's output (secondary) circuit. <b>Doing so could cause a fire.</b></li> <li>Be sure to connect an optional DC reactor (DCR) when the capacity of the power supply transformer exceeds 500 kVA and is 10 times or more the inverter rated capacity. <b>Otherwise, a fire could occur.</b></li> <li>Ground the inverter in compliance with the national or local electric code.</li> <li>Be sure to ground the inverter's grounding terminals . <b>Otherwise, an electric shock or a fire could occur.</b></li> <li>Qualified electricians should carry out wiring.</li> <li>Be sure to perform wiring after turning the power OFF. <b>Otherwise, an electric shock could occur.</b></li> </ul>

## WARNING



- Be sure to perform wiring after installing the inverter unit. **Otherwise, an electric shock or injuries could occur.**
- Ensure that the number of input phases and the rated voltage of the product match the number of phases and the voltage of the AC power supply to which the product is to be connected. **Otherwise, a fire or an accident could occur.**
- Do not connect the power supply wires to output terminals (U, V, and W).
- When connecting a braking resistor, never connect it to terminals other than terminals P(+) and DB. **Doing so could cause fire or an accident.**
- In general, sheaths of the control signal wires are not specifically designed to withstand a high voltage (i.e., reinforced insulation is not applied). Therefore, if a control signal wire comes into direct contact with a live conductor of the main circuit, the insulation of the sheath might break down, which would expose the signal wire to a high voltage of the main circuit. Make sure that the control signal wires will not come into contact with live conductors of the main circuit. **Doing so could cause an accident or an electric shock.**
- Before changing the switches or touching the control circuit terminal symbol plate, turn OFF the power and wait at least five minutes for inverters with a capacity of 22 kW or below, or at least ten minutes for inverters with a capacity of 30 kW or above. Make sure that the LED monitor and charging lamp are turned OFF. Further, make sure, using a multimeter or a similar instrument, that the DC link bus voltage between the terminals P(+) and N(-) has dropped to the safe level (+25 VDC or below). **Otherwise, an electric shock could occur.**

## CAUTION

- The inverter, motor and wiring generate electric noise. Be careful about malfunction of the nearby sensors and devices. To prevent them from malfunctioning, implement noise control measures. **Otherwise an accident could occur.**

### Operation

## WARNING

- Be sure to mount the front cover before turning the power ON. Do not remove the cover when the inverter power is ON. **Otherwise, an electric shock could occur.**
- Do not operate switches with wet hands. **Doing so could cause electric shock.**
- If the auto-reset function has been selected, the inverter may automatically restart and drive the motor depending on the cause of tripping. Design the machinery or equipment so that human safety is ensured at the time of restarting. **Otherwise, an accident could occur.**
- If the stall prevention function (current limiter), automatic deceleration (anti-regenerative control), or overload prevention control has been selected, the inverter may operate with acceleration/deceleration or frequency different from the commanded ones. Design the machine so that safety is ensured even in such cases.
- The  key on the keypad is effective only when the keypad operation is enabled with function code F02 (= 0, 2 or 3). When the keypad operation is disabled, prepare an emergency stop switch separately for safe operations.  
Switching the run command source from keypad (local) to external equipment (remote) by turning ON the "Enable communications link" command **LE** disables the  key. To enable the  key for an emergency stop, select the STOP key priority with function code H96 (= 1 or 3).
- If any of the protective functions have been activated, first remove the cause. Then, after checking that the all run commands are set to OFF, release the alarm. If the alarm is released while any run commands are set to ON, the inverter may supply the power to the motor, running the motor. **Otherwise, an accident could occur.**

## WARNING

- If you enable the "Restart mode after momentary power failure" (Function code F14 = 3 to 5), then the inverter automatically restarts running the motor when the power is recovered. Design the machinery or equipment so that human safety is ensured after restarting.
- If the user configures the function codes wrongly without completely understanding this Instruction Manual and the FRENIC-Mega User's Manual, the motor may rotate with a torque or at a speed not permitted for the machine. **An accident or injuries could occur.**
- Even though the inverter has interrupted power to the motor, if the voltage is applied to the main circuit input terminals L1/R, L2/S and L3/T, voltage may be output to inverter output terminals U, V, and W. **An electric shock may occur.**
- The inverter can easily accept high-speed operation. When changing the speed setting, carefully check the specifications of motors or equipment beforehand. **Otherwise, injuries could occur.**

## CAUTION

- Do not touch the heat sink and braking resistor because they become very hot. **Doing so could cause burns.**
- The DC brake function of the inverter does not provide any holding mechanism. **Injuries could occur.**
- When the inverter is controlled with the digital input signals, switching run or frequency command sources with the related terminal commands (e.g., **SS1, SS2, SS4, SS8, Hz2/Hz1, Hz/PID, IVS, and LE**) may cause a sudden motor start or an abrupt change in speed. **An accident or injuries could occur.**

## Maintenance and inspection, and parts replacement

### **WARNING**

- Before proceeding to the maintenance/inspection jobs, turn OFF the power and wait at least five minutes for inverters with a capacity of 22 kW or below, or at least ten minutes for inverters with a capacity of 30 kW or above. Make sure that the LED monitor and charging lamp are turned OFF. Further, make sure, using a multimeter or a similar instrument, that the DC link bus voltage between the terminals P(+) and N(-) has dropped to the safe level (+25 VDC or below).  
**Otherwise, an electric shock could occur.**
- Maintenance, inspection, and parts replacement should be made only by qualified persons.
- Take off the watch, rings and other metallic objects before starting work.
- Use insulated tools.  
**Otherwise, an electric shock or injuries could occur.**
- Never modify the inverter.  
**Doing so could cause an electric shock or injuries.**

## Disposal

### **CAUTION**

- Treat the inverter as an industrial waste when disposing of it.  
**Otherwise injuries could occur.**

### **GENERAL PRECAUTIONS**

Drawings in this manual may be illustrated without covers or safety shields for explanation of detail parts. Restore the covers and shields in the original state and observe the description in the manual before starting operation.

## Icons

The following icons are used throughout this manual.



This icon indicates information which, if not heeded, can result in the inverter not operating to full efficiency, as well as information concerning incorrect operations and settings which can result in accidents.



This icon indicates information that can prove handy when performing certain settings or operations.



This icon indicates a reference to more detailed information.

## 1.2 Conformity to European standards

The CE marking on Fuji Electric products indicates that they comply with the essential requirements of the Electromagnetic Compatibility (EMC) Directive 2004/108/EC issued by the Council of the European Communities and the Low Voltage Directive 2006/95/EC.

Inverters with built-in EMC filter that bear a CE marking are in conformity with EMC directives. Inverters having no built-in EMC filter can be in conformity with EMC directives if an optional EMC compliant filter is connected to them.

General purpose inverters are subject to the regulations set forth by the Low Voltage Directive in the EU. Fuji Electric declares the inverters bearing a CE marking are compliant with the Low Voltage Directive.

FRENIC Mega inverters are in accordance with the regulations of following council directives and their amendments:

EMC Directive 2004/108/EC (Electromagnetic Compatibility)

Low Voltage Directive 2006/95/EC (LVD)

For assessment of conformity the following relevant standards have been taken into consideration:

EN61800-3:2004

EN61800-5-1:2003

### **CAUTION**

The FRENIC-MEGA inverters are categorized as category C2 or C3 according to the EN61800-3:2004. When you use these products in the domestic environment, you may need to take appropriate countermeasures to reduce or eliminate any noise emitted from these products.

## Chapter 2 MOUNTING THE INVERTER

### 2.1 Operating Environment

Install the inverter in an environment that satisfies the requirements listed in Table 2.1.

Item	Specifications
Site location	Indoors
Ambient temperature	-10 to +50°C (Note 1)
Relative humidity	5 to 95% (No condensation)
Atmosphere	The inverter must not be exposed to dust, direct sunlight, corrosive gases, flammable gases, oil mist, vapor or water drops. Pollution degree 2 (IEC60664-1) (Note 2) The atmosphere can contain a small amount of salt. (0.01 mg/cm <sup>2</sup> or less per year) The inverter must not be subjected to sudden changes in temperature that will cause condensation to form.
Altitude	1,000 m max. (Note 3)
Atmospheric pressure	86 to 106 kPa
Vibration	3 mm (Max. amplitude)      2 to less than 9 Hz
	9.8 m/s <sup>2</sup> 9 to less than 20 Hz
	2 m/s <sup>2</sup> 20 to less than 55 Hz
	1 m/s <sup>2</sup> 55 to less than 200 Hz

Table 2.2 Output Current Derating Factor in Relation to Altitude

Altitude	Output current derating factor
1000 m or lower	1.00
1000 to 1500 m	0.97
1500 to 2000 m	0.95
2000 to 2500 m	0.91
2500 to 3000 m	0.88

(Note 1) When inverters are mounted side-by-side without any clearance between them (22 kW or below), the ambient temperature should be within the range from -10 to +40°C.

(Note 2) Do not install the inverter in an environment where it may be exposed to lint, cotton waste or moist dust or dirt which will clog the heat sink of the inverter. If the inverter is to be used in such an environment, install it in a dustproof panel of your system.

(Note 3) If you use the inverter in an altitude above 1000 m, you should apply an output current derating factor as listed in Table 2.2.

### 2.2 Installing the Inverter

#### (1) Mounting base

Install the inverter on a base made of metal or other non-flammable material. Do not mount the inverter upside down or horizontally.

 <b>WARNING</b>
Install the inverter on a base made of metal or other non-flammable material. <b>Otherwise, a fire could occur.</b>

#### (2) Clearances

Ensure that the minimum clearances indicated in Figure 2.1 are maintained at all times. When installing the inverter in the panel of your system, take extra care with ventilation inside the panel as the ambient temperature easily rises. Do not install the inverter in a small panel with poor ventilation.

#### ■ When mounting two or more inverters

When mounting two or more inverters in the same unit or panel, basically lay them out side by side. When mounting them necessarily one above the other, be sure to separate them with a partition plate or the like so that any heat radiating from an inverter will not affect the one/s above.

As long as the ambient temperature is 40°C or lower, inverters with a capacity of 22 kW or below can be mounted **side by side** without any clearance between them.



\* For the inverters with a capacity of 1.5 kW or below and 30 kW or above, maintain 50 mm clearance to the right and left sides, 100 mm to the front.

Figure 2.1 Mounting Direction and Required Clearances

## ■ When employing external cooling

In external cooling, the heat sink, which dissipates about 70% of the total heat (total loss) generated into air, is situated outside the equipment or the panel. The external cooling, therefore, significantly reduces heat radiating inside the equipment or panel.

To employ external cooling for inverters with a capacity of 22 kW or below, use the external cooling attachment option; for those with a capacity of 30 kW or above, simply change the positions of the mounting bases.

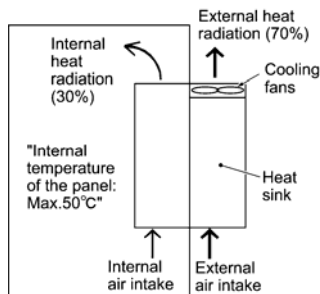

Figure 2.2 External Cooling

## ⚠ CAUTION

Prevent lint, paper fibers, sawdust, dust, metallic chips, or other foreign materials from getting into the inverter or from accumulating on the heat sink.  
**Otherwise, a fire or accident could occur.**

To utilize external cooling for inverters with a capacity of 30 kW or above, change the positions of the top and bottom mounting bases from the edge to the center of the inverter as illustrated in Figure 2.3.

Screws differ in size, length and count for each inverter. Be sure to refer to the table below.

Table 2.3 Screw Count and Tightening Torque

Inverter type	Base fixing screw (Screw type and q'ty)	Case fixing screw (Screw type and q'ty)	Tightening torque (N·m)
FRN30G1S-2□/FRN37G1S-2□ FRN30G1S-4□ to FRN55G1S-4□	M6 x 20 5 pcs for upper side, 3 pcs for lower side	M6 x 20 2 pcs for upper side	5.8
FRN45G1S-2□/FRN55G1S-2□ FRN75G1S-4□	M6 x 20 3 pcs each for upper and lower sides	M6 x 12 3 pcs for upper side	5.8

**Note:** A box (□) in the above table replaces J, E or A depending on the shipping destination.

- 1) Remove all of the base fixing screws from the top and bottom of the inverter. Also remove the case fixing screws from the top. (On the bottom are no case fixing screws.)
- 2) Move the top mounting base to the center of the inverter and secure it with the base fixing screws (2 or 3 pcs), using case fixing screw holes. (After the movement of the top mounting base, 5 or 3 screws are left unused.)
- 3) Move the bottom mounting base to the center of the inverter and secure it with the base fixing screws.

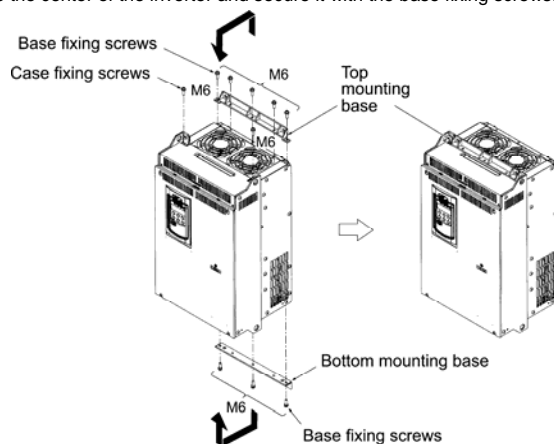

Figure 2.3 Changing the Positions of the Top and Bottom Mounting Bases

## ⚠ CAUTION

When changing the positions of the top and bottom mounting bases, use only the specified screws.  
**Otherwise, a fire or accident could occur.**

## Chapter 3 WIRING THE INVERTER

Follow the procedure below. (In the following description, the inverter has already been installed.)

### 3.1 Removing and mounting the front cover and the wiring guide

#### (1) For inverters with a capacity of 22 kW or below

- ① First loosen the front cover fixing screw, slide the cover downward holding its both sides, tilt it toward you, and then pull it upward, as shown below.
- ② While pressing the wiring guide upward, pull it out toward you.
- ③ After carrying out wiring, put the wiring guide and the front cover back into place in the reverse order of removal.

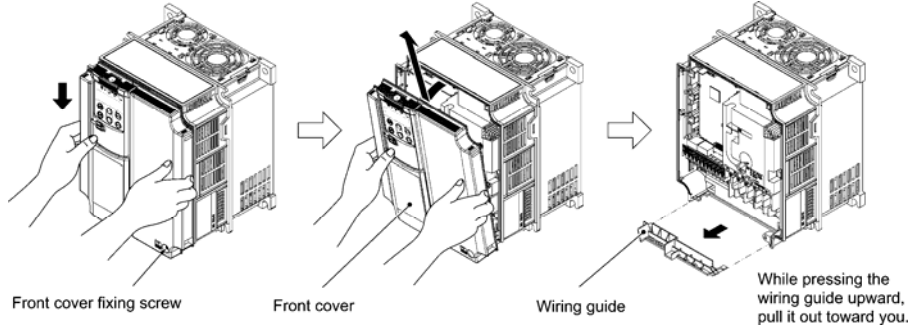
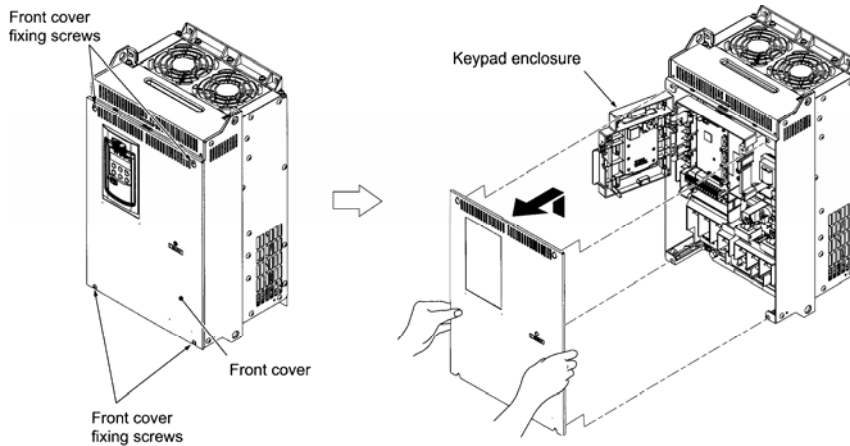

Figure 3.1 Removing the Front Cover and the Wiring Guide

#### (2) For inverters with a capacity of 30 to 75 kW

- ① Loosen the four front cover fixing screws, hold the cover with both hands, slide it upward slightly, and pull it toward you, as shown below.
- ② Open the keypad enclosure.
- ③ After carrying out wiring, align the screw holes provided in the front cover with the screws on the inverter case, then put the front cover back into place in the reverse order of removal.



Tightening torque: 1.8 N·m (M4)  
3.5 N·m (M5)

Figure 3.2 Removing the Front Cover

### 3.2 Terminal arrangement diagram and screw specifications

#### 3.2.1 Arrangement of main circuit terminals

The table and figures given below show the terminal screw sizes, tightening torque and terminal arrangements. Note that the terminal arrangements differ depending on the inverter types. In each of the figures, two grounding terminals (⊕G) are not exclusive to the power supply wiring (primary circuit) or motor wiring (secondary circuit).

Table 3.1 Main Circuit Terminal Properties

Power supply voltage	Nominal applied motor (kW)	Inverter type	HD/LD mode	Terminal screw size	Tightening torque (N·m)	Grounding screw size	Tightening torque (N·m)	Refer to:
Three-phase 400 V	0.4	FRN0.4G1S-4□	HD	M3.5	1.2	M3.5	1.2	Figure A
	0.75	FRN0.75G1S-4□						
	1.5	FRN1.5G1S-4□						
	2.2	FRN2.2G1S-4□		M4	1.8	M4	1.8	Figure B
	3.7	FRN3.7G1S-4□						

Table 3.1 Main Circuit Terminal Properties (continued)

Power supply voltage	Nominal applied motor (kW)	Inverter type	HD/LD mode	Terminal screw size	Tightening torque (N-m)	Grounding screw size	Tightening torque (N-m)	Refer to:
Three-phase 400 V	5.5	FRN5.5G1S-4□	HD	M5	3.5	M5	3.5	Figure C
	7.5		LD					
	11	FRN7.5G1S-4□	HD					
			LD					
	15	FRN11G1S-4□	HD					
			LD					
	18.5	FRN15G1S-4□	HD	M6	5.8	M6	5.8	Figure D
			LD					
	22	FRN18.5G1S-4□	HD					
			LD					
	30	FRN22G1S-4□	HD					
			LD					
	37	FRN30G1S-4□	HD	M8	13.5	M8	13.5	Figure E
			LD					
45	FRN37G1S-4□	HD						
		LD						
55	FRN45G1S-4□	HD						
		LD						
75	FRN55G1S-4□	HD						
		LD						
90	FRN75G1S-4□	LD	M10	27			Figure F	

Terminal R0, T0: Screw size M3.5, Tightening torque 1.2 N-m (for all types)

Terminal R1, T1: Screw size M3.5, Tightening torque 1.2 N-m (75 kW or above)

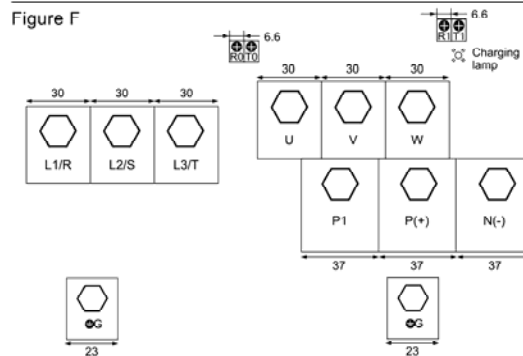
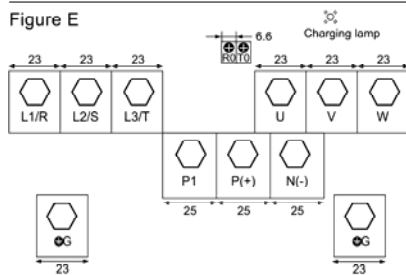
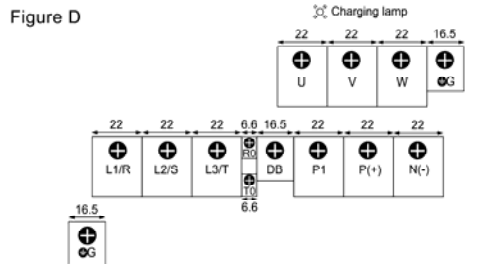
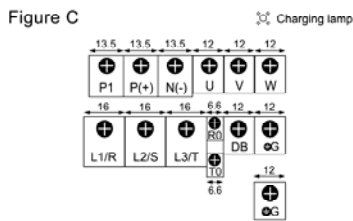
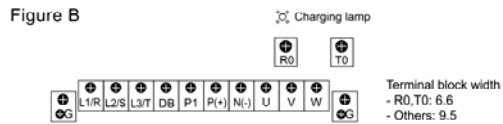
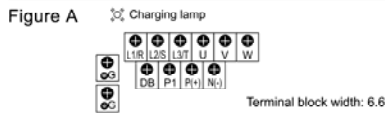

### 3.2.1 Arrangement of control circuit terminals (common to all inverter types)

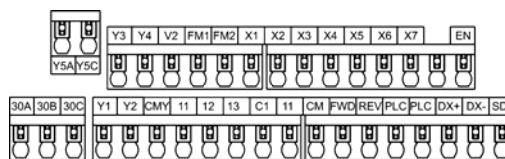

### 3.3 Switching connectors

The switching connectors are located on the power printed circuit board (power PCB) as shown below.

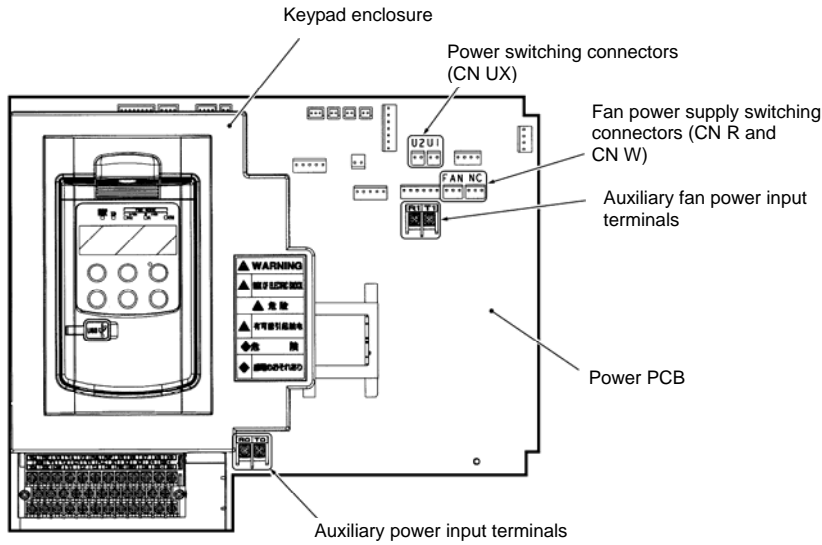

Figure 3.3 Location of Switching Connectors and Auxiliary Power Input Terminals

■ Power switching connectors (CN UX) (for 400 V class series with 75 kW or above)

The 400 V class series with 75 kW or above is equipped with a set of switching connectors (male) which should be configured according to the power source voltage and frequency. By factory default, a jumper (female connector) is set to U1. If the power supply to the main power inputs (L1/R, L2/S, L3/T) or the auxiliary fan power input terminals (R1, T1) matches the conditions listed below, change the jumper to U2.

Connector configuration	CN UX (red)	CN UX (red)
Power source voltage	398 to 440 V/50 Hz, 430 to 480 V/60 Hz (Factory default)	380 to 398 V/50 Hz 380 to 430 V/60 Hz

**Note** The allowable power input voltage fluctuation is within -15% to +10% of the power source voltage.

■ Fan power supply switching connectors (CN R and CN W) (for 200 V class series with 37 kW or above and 400 V class series with 75 kW or above)

The standard FRENIC-MEGA series accepts DC-linked power input in combination with a PWM converter. The 200 V class series with 37 kW or above and 400 V class series with 75 kW or above, however, contain AC-driven components such as AC fans. To supply AC power to those components, exchange the CN R and CN W connectors as shown below and connect the AC power line to the auxiliary fan power input terminals (R1, T1).

Connector configuration	CN R (red) CN W (white)	CN W (white) CN R (red)
Use conditions	When not using terminal R1 or T1 (Factory default)	When using terminals R1 and T1 <ul style="list-style-type: none"> <li>Feeding the DC-linked power</li> <li>Combined with a PWM converter</li> </ul>

**Note** By factory default, the fan power supply switching connectors CN R and CN W are set on the **FAN** and **NC** positions, respectively. Do not exchange them unless you drive the inverter with a DC-linked power supply.

Wrong configuration of these switching connectors cannot drive the cooling fans, causing a heat sink overheat alarm *Oh1* or a charger circuit alarm *pbF*.

## 3.4 Wiring of main circuit terminals, grounding terminals and control circuit terminals

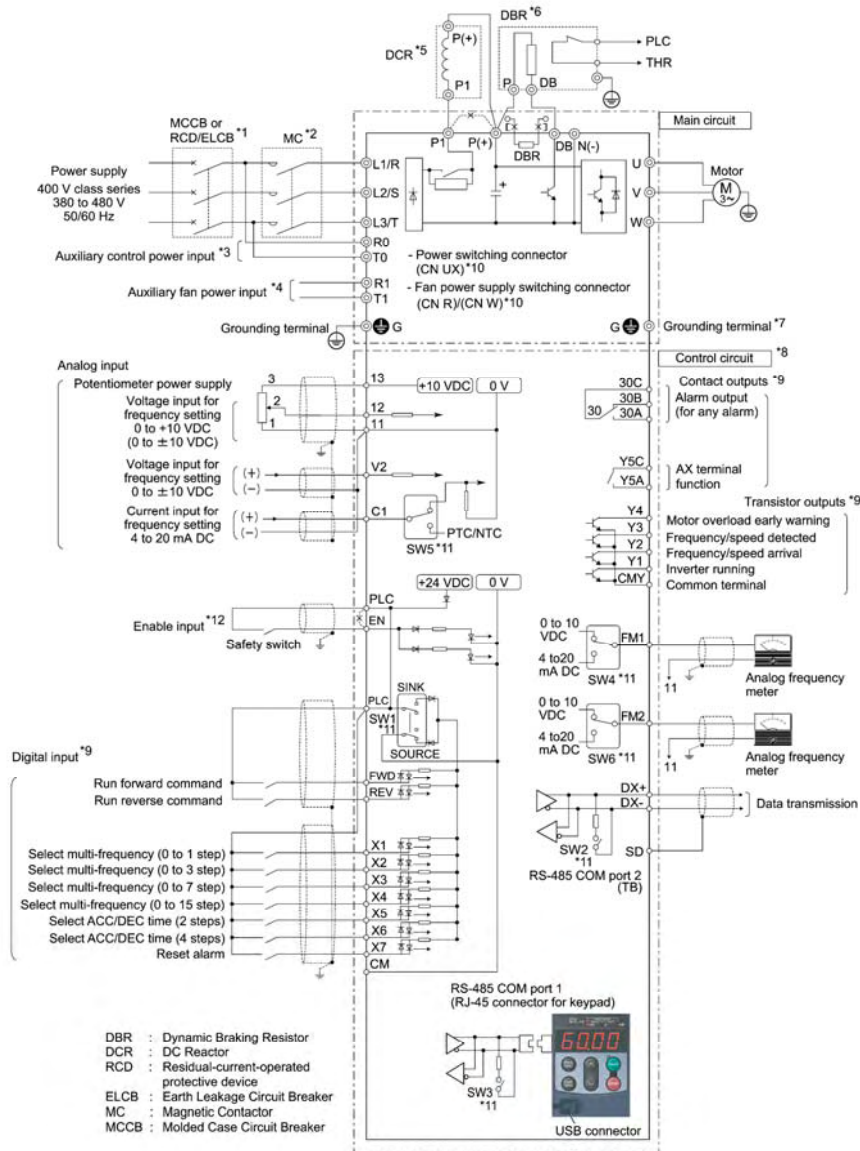

- \*1 Install a recommended molded case circuit breaker (MCCB) or residual-current-operated protective device (RCD)/earth leakage circuit breaker (ELCB) (with overcurrent protection function) in the primary circuit of the inverter to protect wiring. Ensure that the circuit breaker capacity is equivalent to or lower than the recommended capacity.
- \*2 Install a magnetic contactor (MC) for each inverter to separate the inverter from the power supply, apart from the MCCB or RCD/ELCB, when necessary. Connect a surge absorber in parallel when installing a coil such as the MC or solenoid near the inverter.
- \*3 To retain an alarm output signal **ALM** issued on inverter's programmable output terminals by the protective function or to keep the keypad alive even if the main power has shut down, connect these terminals to the power supply lines. Without power supply to these terminals, the inverter can run.
- \*4 Normally no need to be connected. Use these terminals when the inverter is equipped with a high power-factor, regenerative PWM converter RHC series (hereinafter called PWM converter).
- \*5 When connecting an optional DC reactor (DCR), remove the jumper bar from the terminals P1 and P(+).  
LD-mode inverters with a capacity of 55 kW and inverters with 75 kW or above are equipped with a DC reactor (DCR) as standard. Be sure to connect the DCR.  
Use a DCR when the capacity of the power supply transformer exceeds 500 kVA and is 10 times or more the inverter rated capacity, or when there are thyristor-driven loads in the same power supply line.
- \*6 Inverters with a capacity of 7.5 kW or below have a built-in braking resistor (DBR) between the terminals P(+) and DB.  
When connecting an external braking resistor (DBR), remove the built-in one.
- \*7 A grounding terminal for a motor. Use this terminal if needed.
- \*8 For control signal wires, use twisted or shielded-twisted wires. When using shielded-twisted wires, connect the shield of them to the common terminals of the control circuit. To prevent malfunction due to noise, keep the control circuit wiring away from the main circuit wiring as far as possible (recommended: 10 cm or more). Never install them in the same wire duct. When crossing the control circuit wiring with the main circuit wiring, set them at right angles.

- \*9 The connection diagram shows factory default functions assigned to digital input terminals [X1] to [X7], [FWD] and [REV], transistor output terminals [Y1] to [Y4], and relay contact output terminals [Y5A/C] and [30A/B/C].
- \*10 Switching connectors in the main circuits. For details, refer to "Switching connectors" later in this section.
- \*11 Slide switches on the control printed circuit board (control PCB). Use these switches to customize the inverter operations. For details about the slide switch setting, refer to Section 3.4 "Setting up the slide switches."
- \*12 When using the Enable input function, be sure to remove the jumper wire from terminals [EN] and [PLC]. For opening and closing the hardware circuit between terminals [EN] and [PLC], use safety components such as safety relays and safety switches that comply with EN954-1, Category 3 or higher. Be sure to use shielded wires exclusive to terminals [EN] and [PLC]. Do not put them together with any other control signal wire in the same shielded core. Ground the shielding layer. When not using the Enable input function, keep the terminals between [EN] and [PLC] short-circuited with the jumper wire (factory default).

Table 3.2 Main circuit terminals and grounding terminals description and wiring.

Power supply voltage	Nominal applied motor	Inverter type	HD/LD mode	MCCB or RCD/ELCB *1 Rated current		Recommended wire size (mm <sup>2</sup> )									
						Main terminal				Inverter outputs *2 [U, V, W]	DC reactor [P1, P(+)] *2	Braking resistor [P(+), DB] *2	Control circuit	Aux. control power supply [R0, T0]	Aux. fan power supply [R1, T1]
						W/DCR	W/o DCR	W/DCR	W/o DCR						
Three-phase 400 V	0.4	FRN0.4G1■-4□	HD	5	5	1	1	1	1	1	0.65 to 0.82	2.5	—		
	0.75	FRN0.75G1■-4□												10	10
	1.5	FRN1.5G1■-4□		15	15		2.5								
	2.2	FRN2.2G1■-4□												20	20
	4.0	FRN4.0G1■-4E		30	30		6								
	5.5	FRN5.5G1■-4□	40			40		10							
	7.5	FRN7.5G1■-4□		50	50		16								
	11	FRN11G1■-4□	60			60		25							
		FRN11G1■-4□		75	75		35								
	15	FRN15G1■-4□	100			100		50							
		FRN15G1■-4□		125	125		70								
	18.5	FRN18.5G1■-4□	150			150		100							
		FRN18.5G1■-4□		200	200		150								
	22	FRN22G1■-4□	200			200		200							
		FRN22G1■-4□		250	250		250								
	30	FRN30G1■-4□	250			250		250							
		FRN30G1■-4□		300	300		300								
	37	FRN37G1■-4□	300			300		300							
		FRN37G1■-4□		350	350		350								
	45	FRN45G1■-4□	350			350		350							
FRN45G1■-4□		400		400	400										
55	FRN55G1■-4□		400			400	400								
	FRN55G1■-4□	450		450	450										
75	FRN75G1■-4□		450			450	450								
	FRN75G1■-4□	500		500	500										
90	FRN90G1■-4□		500			500	500	500	500	500	500	4	—	2.5	

A box (■) in the above table replaces S or E depending on the enclosure.

A box (□) in the above table replaces A or E depending on the shipping destination.

\*1 The frame size and model of the MCCB or RCD/ELCB (with overcurrent protection) will vary depending on the power transformer capacity. Refer to the related technical documentation for details.

\*2 The recommended wire size for main circuits is for the 70°C 600 V PVC wires used at a surrounding temperature of 40°C.

■ Connecting/disconnecting wires to/from a control circuit terminal

① Strip the wire end by 8 to 10 mm as shown below.

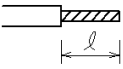
Strip length of wire end	8 to 10 mm	
Type of screwdriver (tip shape)	Flat (0.6 x 3.5 mm)	

**Note** For strand wires, the strip length specified above should apply after twisting of them.  
If the strip length is out of the specified range, the wire may not be firmly clamped or may be short-circuited with other wires.

- ② Twist the end of the stripped wires for easy insertion and insert it firmly into the wire inlet on the control circuit terminal. If the insertion is difficult, hold down the clamp release button on the terminal with a flat screwdriver.
- ③ When disconnecting the wires from the terminal, hold down the clamp release button on the terminal with a flat screwdriver and pull out the wires.

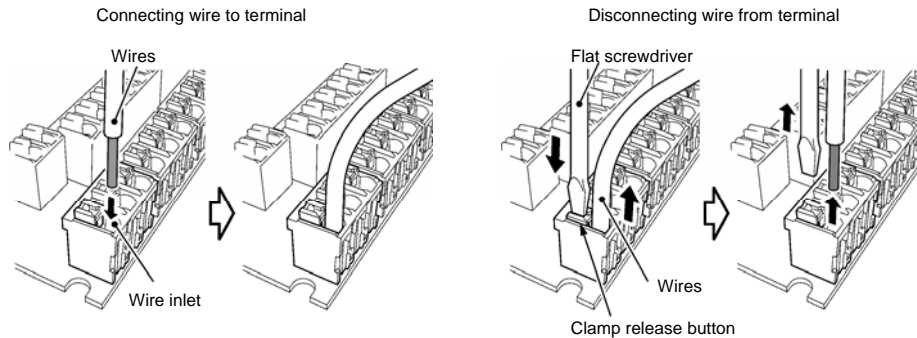

Table 3.3 Symbols, Names and Functions of the Control Circuit Terminals

Classification	Symbol	Name	Functions
Analog input	[13]	Potentiometer power supply	Power supply (+10 VDC) for frequency command potentiometer (Variable resistor: 1 to 5kΩ) The potentiometer of 1/2 W rating or more should be connected.
	[12] [V2]	Analog setting voltage inputs	<ol style="list-style-type: none"> <li>(1) The frequency is commanded according to the external voltage input. <ul style="list-style-type: none"> <li>• 0 to ±10 VDC/0 to ±100% (Normal operation)</li> <li>• +10 to 0 VDC/0 to 100% (Inverse operation)</li> </ul> </li> <li>(2) In addition to frequency setting, PID command, PID feedback signal, auxiliary frequency command setting, ratio setting, torque limiter level setting, or analog input monitor can be assigned to this terminal.</li> <li>(3) Hardware specifications <ul style="list-style-type: none"> <li>• Input impedance: 22kΩ</li> <li>• The maximum input is ±15 VDC, however, the voltage higher than ±10 VDC is handled as ±10 VDC.</li> <li>• Inputting a bipolar analog voltage (0 to ±10 VDC) to terminal [12] requires setting function code C35 to "0."</li> <li>• Inputting a bipolar analog voltage (0 to ±10 VDC) to terminal [V2] requires setting function code C45 to "0."</li> </ul> </li> </ol>
	[C1]	Analog setting current input	<ol style="list-style-type: none"> <li>(1) The frequency is commanded according to the external current input. <ul style="list-style-type: none"> <li>• 4 to 20 mA DC/0 to 100% (Normal operation)</li> <li>• 20 to 4 mA DC/0 to 100 % (Inverse operation)</li> </ul> </li> <li>(2) In addition to frequency setting, PID command, PID feedback signal, auxiliary frequency command setting, ratio setting, torque limiter level setting, or analog input monitor can be assigned to this terminal.</li> <li>(3) Hardware specifications <ul style="list-style-type: none"> <li>• Input impedance: 250Ω</li> <li>• The maximum input is +30 mA DC, however, the current larger than +20 mA DC is handled as +20 mA DC.</li> </ul> </li> </ol>
	[C1]	PTC/NTC thermistor input	<ol style="list-style-type: none"> <li>(1) Connects PTC (Positive Temperature Coefficient)/NTC (Negative Temperature Coefficient) thermistor for motor protection. Ensure that the slide switch SW5 on the control PCB is turned to the PTC/NTC position (see Section 3.4 "Setting up the slide switches").</li> </ol> <p>The figure shown at the right illustrates the internal circuit diagram where SW5 (switching the input of terminal [C1] between C1 and PTC/NTC) is turned to the PTC/NTC position. For details on SW5, refer to Section 3.4 "Setting up the slide switches." In this case, you must change data of the function code H26.</p>
	[11]	Analog common	Common for analog input/output signals ([13], [12], [C1], [V2], [FM1] and [FM2]). Isolated from terminals [CM] and [CMY].

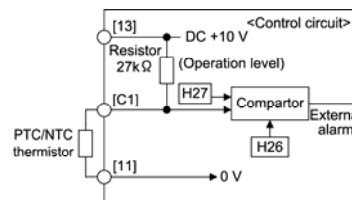

Figure 3.4 Internal Circuit Diagram (SW5 Selecting PTC/NTC)

Table 3.3 Symbols, Names and Functions of the Control Circuit Terminals (Continued)

Classification	Symbol	Name	Functions																																																
Analog input		<p><b>Note</b></p> <ul style="list-style-type: none"> <li>- Since low level analog signals are handled, these signals are especially susceptible to the external noise effects. Route the wiring as short as possible (within 20 m) and use shielded wires. In principle, ground the shielded sheath of wires; if effects of external inductive noises are considerable, connection to terminal [11] may be effective. As shown in Figure 3.5, be sure to ground the single end of the shield to enhance the shield effect.</li> <li>- Use a twin-contact relay for low level signals if the relay is used in the control circuit. Do not connect the relay's contact to terminal [11].</li> <li>- When the inverter is connected to an external device outputting the analog signal, the external device may malfunction due to electric noise generated by the inverter. If this happens, according to the circumstances, connect a ferrite core (a toroidal core or equivalent) to the device outputting the analog signal or connect a capacitor having the good cut-off characteristics for high frequency between control signal wires as shown in Figure 3.6</li> <li>- Do not apply a voltage of +7.5 VDC or higher to terminal [C1]. Doing so could damage the internal control circuit.</li> </ul>	<div style="display: flex; justify-content: space-around;"> <div style="text-align: center;">  <p>Figure 3.5 Connection of Shielded Wire</p> </div> <div style="text-align: center;">  <p>Figure 3.6 Example of Electric Noise Reduction</p> </div> </div>																																																
				<table border="1"> <tr> <td>[CM]</td> <td>Digital input common</td> <td>Two common terminals for digital input signals These terminals are electrically isolated from the terminals [11]s and [CMY].</td> </tr> <tr> <td>[X1]</td> <td>Digital input 1</td> <td rowspan="7"> <p>(1) Various signals such as "Coast to a stop," "Enable external alarm trip," and "Select multi-frequency" can be assigned to terminals [X1] to [X7], [FWD] and [REV] by setting function codes E01 to E07, E98, and E99. For details, refer to Chapter 6.</p> <p>(2) Input mode, i.e. SINK/SOURCE, is changeable by using the slide switch SW1. (Refer to Section 3.4, "Setting up the slide switches.") The factory default for FRN __ _G1 ■-2A/4A is SINK, and for FRN __ _G1 ■-4E, SOURCE.</p> <p>(3) Switches the logic value (1/0) for ON/OFF of the terminals [X1] to [X7], [FWD], or [REV]. If the logic value for ON of the terminal [X1] is 1 in the normal logic system, for example, OFF is 1 in the negative logic system and vice versa.</p> <p>(4) Digital input terminal [X7] can be set up as a pulse train input terminal. Maximum wiring length 20 m Maximum input pulse 30 kHz: When connected to a pulse generator with open collector transistor output. (Needs a pull-up or pull-down resistor. See note below.) 100 kHz: When connected to a pulse generator with complementary transistor output</p> <p><b>Note:</b> Stray capacitance on the wiring between the pulse generator and the inverter may disable transmission of the pulse train. As a countermeasure against this problem, insert a pull-up resistor between the open collector output signal (terminal [X7]) and the power source terminal (terminal [PLC]) if the switch selects the SINK mode input; insert a pull-down resistor between the output signal and the digital common terminal (terminal [CM]) if the switch selects the SOURCE mode input. A recommended pull-up/down resistor is 1kΩ 2 W. Check if the pulse train is correctly transmitted because stray capacity is significantly affected by the wire types and wiring conditions.</p> <p>(Digital input circuit specifications)</p> <div style="display: flex; align-items: flex-start;"> <div style="flex: 1;">  <p>Figure 3.7 Digital Input Circuit</p> </div> <div style="flex: 1;"> <table border="1"> <thead> <tr> <th>Item</th> <th>Min.</th> <th>Max.</th> </tr> </thead> <tbody> <tr> <td rowspan="2">Operating voltage (SINK)</td> <td>ON level</td> <td>0 V</td> <td>2 V</td> </tr> <tr> <td>OFF level</td> <td>22 V</td> <td>27 V</td> </tr> <tr> <td rowspan="2">Operating voltage (SOURCE)</td> <td>ON level</td> <td>22 V</td> <td>27 V</td> </tr> <tr> <td>OFF level</td> <td>0 V</td> <td>2 V</td> </tr> <tr> <td rowspan="2">Operating current at ON (Input voltage is at 0 V) (For [X7])</td> <td></td> <td>2.5 mA</td> <td>5 mA</td> </tr> <tr> <td></td> <td>(9.7 mA)</td> <td>(16 mA)</td> </tr> <tr> <td>Allowable leakage current at OFF</td> <td>-</td> <td>0.5 mA</td> </tr> </tbody> </table> </div> </div> </td> </tr> <tr> <td>[X2]</td> <td>Digital input 2</td> <td rowspan="7"></td> </tr> <tr> <td>[X3]</td> <td>Digital input 3</td> </tr> <tr> <td>[X4]</td> <td>Digital input 4</td> </tr> <tr> <td>[X5]</td> <td>Digital input 5</td> </tr> <tr> <td>[X6]</td> <td>Digital input 6</td> </tr> <tr> <td>[X7]</td> <td>Digital input 7</td> </tr> <tr> <td>[FWD]</td> <td>Run forward command</td> <td rowspan="2">  <p>Figure 3.7 Digital Input Circuit</p> </td> </tr> <tr> <td>[REV]</td> <td>Run reverse command</td> </tr> </table>	[CM]	Digital input common	Two common terminals for digital input signals These terminals are electrically isolated from the terminals [11]s and [CMY].	[X1]	Digital input 1	<p>(1) Various signals such as "Coast to a stop," "Enable external alarm trip," and "Select multi-frequency" can be assigned to terminals [X1] to [X7], [FWD] and [REV] by setting function codes E01 to E07, E98, and E99. For details, refer to Chapter 6.</p> <p>(2) Input mode, i.e. SINK/SOURCE, is changeable by using the slide switch SW1. (Refer to Section 3.4, "Setting up the slide switches.") The factory default for FRN __ _G1 ■-2A/4A is SINK, and for FRN __ _G1 ■-4E, SOURCE.</p> <p>(3) Switches the logic value (1/0) for ON/OFF of the terminals [X1] to [X7], [FWD], or [REV]. If the logic value for ON of the terminal [X1] is 1 in the normal logic system, for example, OFF is 1 in the negative logic system and vice versa.</p> <p>(4) Digital input terminal [X7] can be set up as a pulse train input terminal. Maximum wiring length 20 m Maximum input pulse 30 kHz: When connected to a pulse generator with open collector transistor output. (Needs a pull-up or pull-down resistor. See note below.) 100 kHz: When connected to a pulse generator with complementary transistor output</p> <p><b>Note:</b> Stray capacitance on the wiring between the pulse generator and the inverter may disable transmission of the pulse train. As a countermeasure against this problem, insert a pull-up resistor between the open collector output signal (terminal [X7]) and the power source terminal (terminal [PLC]) if the switch selects the SINK mode input; insert a pull-down resistor between the output signal and the digital common terminal (terminal [CM]) if the switch selects the SOURCE mode input. A recommended pull-up/down resistor is 1kΩ 2 W. Check if the pulse train is correctly transmitted because stray capacity is significantly affected by the wire types and wiring conditions.</p> <p>(Digital input circuit specifications)</p> <div style="display: flex; align-items: flex-start;"> <div style="flex: 1;">  <p>Figure 3.7 Digital Input Circuit</p> </div> <div style="flex: 1;"> <table border="1"> <thead> <tr> <th>Item</th> <th>Min.</th> <th>Max.</th> </tr> </thead> <tbody> <tr> <td rowspan="2">Operating voltage (SINK)</td> <td>ON level</td> <td>0 V</td> <td>2 V</td> </tr> <tr> <td>OFF level</td> <td>22 V</td> <td>27 V</td> </tr> <tr> <td rowspan="2">Operating voltage (SOURCE)</td> <td>ON level</td> <td>22 V</td> <td>27 V</td> </tr> <tr> <td>OFF level</td> <td>0 V</td> <td>2 V</td> </tr> <tr> <td rowspan="2">Operating current at ON (Input voltage is at 0 V) (For [X7])</td> <td></td> <td>2.5 mA</td> <td>5 mA</td> </tr> <tr> <td></td> <td>(9.7 mA)</td> <td>(16 mA)</td> </tr> <tr> <td>Allowable leakage current at OFF</td> <td>-</td> <td>0.5 mA</td> </tr> </tbody> </table> </div> </div>	Item	Min.	Max.	Operating voltage (SINK)	ON level	0 V	2 V	OFF level	22 V	27 V	Operating voltage (SOURCE)	ON level	22 V	27 V	OFF level	0 V	2 V	Operating current at ON (Input voltage is at 0 V) (For [X7])		2.5 mA	5 mA		(9.7 mA)	(16 mA)	Allowable leakage current at OFF	-	0.5 mA	[X2]	Digital input 2		[X3]	Digital input 3	[X4]	Digital input 4	[X5]	Digital input 5	[X6]	Digital input 6	[X7]	Digital input 7	[FWD]
[CM]	Digital input common	Two common terminals for digital input signals These terminals are electrically isolated from the terminals [11]s and [CMY].																																																	
[X1]	Digital input 1	<p>(1) Various signals such as "Coast to a stop," "Enable external alarm trip," and "Select multi-frequency" can be assigned to terminals [X1] to [X7], [FWD] and [REV] by setting function codes E01 to E07, E98, and E99. For details, refer to Chapter 6.</p> <p>(2) Input mode, i.e. SINK/SOURCE, is changeable by using the slide switch SW1. (Refer to Section 3.4, "Setting up the slide switches.") The factory default for FRN __ _G1 ■-2A/4A is SINK, and for FRN __ _G1 ■-4E, SOURCE.</p> <p>(3) Switches the logic value (1/0) for ON/OFF of the terminals [X1] to [X7], [FWD], or [REV]. If the logic value for ON of the terminal [X1] is 1 in the normal logic system, for example, OFF is 1 in the negative logic system and vice versa.</p> <p>(4) Digital input terminal [X7] can be set up as a pulse train input terminal. Maximum wiring length 20 m Maximum input pulse 30 kHz: When connected to a pulse generator with open collector transistor output. (Needs a pull-up or pull-down resistor. See note below.) 100 kHz: When connected to a pulse generator with complementary transistor output</p> <p><b>Note:</b> Stray capacitance on the wiring between the pulse generator and the inverter may disable transmission of the pulse train. As a countermeasure against this problem, insert a pull-up resistor between the open collector output signal (terminal [X7]) and the power source terminal (terminal [PLC]) if the switch selects the SINK mode input; insert a pull-down resistor between the output signal and the digital common terminal (terminal [CM]) if the switch selects the SOURCE mode input. A recommended pull-up/down resistor is 1kΩ 2 W. Check if the pulse train is correctly transmitted because stray capacity is significantly affected by the wire types and wiring conditions.</p> <p>(Digital input circuit specifications)</p> <div style="display: flex; align-items: flex-start;"> <div style="flex: 1;">  <p>Figure 3.7 Digital Input Circuit</p> </div> <div style="flex: 1;"> <table border="1"> <thead> <tr> <th>Item</th> <th>Min.</th> <th>Max.</th> </tr> </thead> <tbody> <tr> <td rowspan="2">Operating voltage (SINK)</td> <td>ON level</td> <td>0 V</td> <td>2 V</td> </tr> <tr> <td>OFF level</td> <td>22 V</td> <td>27 V</td> </tr> <tr> <td rowspan="2">Operating voltage (SOURCE)</td> <td>ON level</td> <td>22 V</td> <td>27 V</td> </tr> <tr> <td>OFF level</td> <td>0 V</td> <td>2 V</td> </tr> <tr> <td rowspan="2">Operating current at ON (Input voltage is at 0 V) (For [X7])</td> <td></td> <td>2.5 mA</td> <td>5 mA</td> </tr> <tr> <td></td> <td>(9.7 mA)</td> <td>(16 mA)</td> </tr> <tr> <td>Allowable leakage current at OFF</td> <td>-</td> <td>0.5 mA</td> </tr> </tbody> </table> </div> </div>	Item	Min.	Max.	Operating voltage (SINK)	ON level	0 V	2 V		OFF level	22 V	27 V	Operating voltage (SOURCE)	ON level	22 V	27 V	OFF level	0 V	2 V	Operating current at ON (Input voltage is at 0 V) (For [X7])		2.5 mA	5 mA		(9.7 mA)	(16 mA)	Allowable leakage current at OFF	-	0.5 mA																					
Item	Min.		Max.																																																
Operating voltage (SINK)	ON level		0 V	2 V																																															
	OFF level		22 V	27 V																																															
Operating voltage (SOURCE)	ON level		22 V	27 V																																															
	OFF level		0 V	2 V																																															
Operating current at ON (Input voltage is at 0 V) (For [X7])			2.5 mA	5 mA																																															
		(9.7 mA)	(16 mA)																																																
Allowable leakage current at OFF	-	0.5 mA																																																	
[X2]	Digital input 2																																																		
[X3]	Digital input 3																																																		
[X4]	Digital input 4																																																		
[X5]	Digital input 5																																																		
[X6]	Digital input 6																																																		
[X7]	Digital input 7																																																		
[FWD]	Run forward command		 <p>Figure 3.7 Digital Input Circuit</p>																																																
[REV]	Run reverse command																																																		

Table 3.3 Symbols, Names and Functions of the Control Circuit Terminals (Continued)

Classification	Symbol	Name	Functions																
Digital input	[EN]	Enable input	<p>(1) Safety stop function that is compliant with EN954-1, Category 3. This terminal allows the hardware circuit to stop the inverter's output transistor and coast the motor to a stop.</p> <p>(2) This terminal is exclusively used for the source mode input. When it is short-circuited with terminal [PLC], the Enable input is ON (ready for inverter run); when it is opened, the inverter coasts the motor to stop. This terminal is not interlocked with the slide switch SW1.</p> <p>(3) By factory default, terminals [EN] and [PLC] are short-circuited with each other using a jumper wire, disabling this function. To enable it, be sure to remove the jumper wire. For details of connection to this terminal and precautions, refer to the Instruction Manual.</p>																
			<p>&lt;Terminal [EN] circuit specification&gt;</p>  <table border="1" data-bbox="869 593 1197 806"> <thead> <tr> <th>Item</th> <th>Min.</th> <th>Max.</th> </tr> </thead> <tbody> <tr> <td rowspan="2">Operating voltage (SOURCE)</td> <td>ON level</td> <td>22 V</td> <td>27 V</td> </tr> <tr> <td>OFF level</td> <td>0 V</td> <td>2 V</td> </tr> <tr> <td>Operating current at ON (Input voltage is at 24 V)</td> <td>5 mA</td> <td>10 mA</td> </tr> <tr> <td>Allowable leakage current at OFF</td> <td>-</td> <td>0.5 mA</td> </tr> </tbody> </table>	Item	Min.	Max.	Operating voltage (SOURCE)	ON level	22 V	27 V	OFF level	0 V	2 V	Operating current at ON (Input voltage is at 24 V)	5 mA	10 mA	Allowable leakage current at OFF	-	0.5 mA
	Item	Min.	Max.																
Operating voltage (SOURCE)	ON level	22 V	27 V																
	OFF level	0 V	2 V																
Operating current at ON (Input voltage is at 24 V)	5 mA	10 mA																	
Allowable leakage current at OFF	-	0.5 mA																	
[PLC]	PLC signal power	<p>(1) Connects to PLC output signal power supply. Rated voltage: +24 VDC (Allowable range: +22 to +27 VDC), Maximum 100 mA DC</p> <p>(2) This terminal also supplies power to the load connected to the transistor output terminals. Refer to "Transistor output" described later in this table for more information</p>																	
<p><b>Tip</b> ■ Using a relay contact to turn [X1] to [X7], [FWD], or [REV] ON or OFF</p> <p>Figure 3.8 shows two examples of a circuits that use a relay contact to turn control signal input [X1] to [X7], [FWD], or [REV] ON or OFF. In circuit (a), the slide switch SW1 has been turned to SINK, whereas in circuit (b) it has been turned to SOURCE. To configure this kind of circuit, use a highly reliable relay.</p>  <p>(a) With the switch turned to SINK                      (b) With the switch turned to SOURCE</p> <p>Figure 3.8 Circuit Configuration Using a Relay Contact</p>																			
<p><b>Tip</b> ■ Using a programmable logic controller (PLC) to turn [X1] to [X7], [FWD], or [REV] ON or OFF</p> <p>Figure 3.9 shows two examples of a circuit that use a programmable logic controller (PLC) to turn control signal input [X1] to [X7], [FWD], or [REV] ON or OFF. In circuit (a), the slide switch SW1 has been turned to SINK, whereas in circuit (b) it has been turned to SOURCE. In circuit (a) below, short-circuiting or opening the transistor's open collector circuit in the PLC using an external power supply turns ON or OFF control signal [X1] to [X7], [FWD], or [REV]. When using circuit (a), observe the following:</p> <ul style="list-style-type: none"> <li>- Connect the + node of the external power supply (which should be isolated from the PLC's power) to terminal [PLC] of the inverter.</li> <li>- Do not connect terminal [CM] of the inverter to the common terminal of the PLC.</li> </ul>																			

Table 3.3 Symbols, Names and Functions of the Control Circuit Terminals (Continued)

Classification	Symbol	Name	Functions																							
Digital input																										
	<p>(a) With the switch turned to SINK                      (b) With the switch turned to SOURCE</p> <p>Figure 3.9 Circuit Configuration Using a PLC</p> <p>For details about the slide switch setting, refer to Section 3.4 "Setting up the slide switches."</p>																									
Analog output	[FM1] [FM2]	Analog monitor	<p>Both terminals output monitor signals for analog DC voltage (0 to +10 V) or analog DC current (+4 to +20 mA). The output form (VO/IO) for each of [FM1] and [FM2] can be switched with the slide switches on the control PCB and the function codes.</p> <table border="1"> <thead> <tr> <th rowspan="2">Terminal</th> <th rowspan="2">Terminal function is specified by</th> <th colspan="2">Output form</th> <th rowspan="2">Content is specified by</th> </tr> <tr> <th>Analog DC voltage</th> <th>Analog DC current</th> </tr> </thead> <tbody> <tr> <td rowspan="2">[FM1]</td> <td>Slide switch SW4</td> <td>VO1</td> <td>IO1</td> <td rowspan="2">Function code F31</td> </tr> <tr> <td>Function code F29</td> <td>0</td> <td>1</td> </tr> <tr> <td rowspan="2">[FM2]</td> <td>Slide switch SW6</td> <td>VO2</td> <td>IO2</td> <td rowspan="2">Function code F35</td> </tr> <tr> <td>Function code F32</td> <td>0</td> <td>1</td> </tr> </tbody> </table> <p>* Input impedance of the external device: Min. 5kΩ (at 0 to 10 VDC output) (While the terminal is outputting 0 to 10 VDC, it is capable of driving up to two analog voltmeters with 10 kΩ impedance.)</p> <p>* Input impedance of the external device: Max. 500Ω (at 4 to 20 mA DC output)</p> <p>* Adjustable range of the gain: 0 to 300%</p>	Terminal	Terminal function is specified by	Output form		Content is specified by	Analog DC voltage	Analog DC current	[FM1]	Slide switch SW4	VO1	IO1	Function code F31	Function code F29	0	1	[FM2]	Slide switch SW6	VO2	IO2	Function code F35	Function code F32	0	1
	Terminal	Terminal function is specified by	Output form			Content is specified by																				
Analog DC voltage			Analog DC current																							
[FM1]	Slide switch SW4	VO1	IO1	Function code F31																						
	Function code F29	0	1																							
[FM2]	Slide switch SW6	VO2	IO2	Function code F35																						
	Function code F32	0	1																							
Transistor output	[Y1]	Transistor output 1	<p>(1) Various signals such as inverter running, speed/freq. arrival and overload early warning can be assigned to any terminals, [Y1] to [Y4] by setting function code E20 to E24. Refer to Chapter 6.</p> <p>(2) Switch the logic value (1/0) for ON/OFF of the terminals between [Y1] to [Y4], and [CMY]. If the logic value for ON between [Y1] to [Y4] and [CMY] is 1 in the normal logic system, for example, OFF is 1 in the negative logic system and vice versa.</p>																							
	[Y2]	Transistor output 2																								
	[Y3]	Transistor output 3	<p>(Transistor output circuit specification)</p> <table border="1"> <thead> <tr> <th colspan="2">Item</th> <th>Max.</th> </tr> </thead> <tbody> <tr> <td rowspan="2">Operation voltage</td> <td>ON level</td> <td>2 V</td> </tr> <tr> <td>OFF level</td> <td>27 V</td> </tr> <tr> <td colspan="2">Maximum current at ON</td> <td>50 mA</td> </tr> <tr> <td colspan="2">Leakage current at OFF</td> <td>0.1 mA</td> </tr> </tbody> </table> <p>Figure 3.10 Transistor Output Circuit</p> <p>Figure 3.11 shows examples of connection between the control circuit and a PLC.</p>	Item		Max.	Operation voltage	ON level	2 V	OFF level	27 V	Maximum current at ON		50 mA	Leakage current at OFF		0.1 mA									
	Item		Max.																							
	Operation voltage	ON level	2 V																							
OFF level		27 V																								
Maximum current at ON		50 mA																								
Leakage current at OFF		0.1 mA																								
[Y4]	Transistor output 4	<p><b>Note</b></p> <ul style="list-style-type: none"> <li>- When a transistor output drives a control relay, connect a surge-absorbing diode across relay's coil terminals.</li> <li>- When any equipment or device connected to the transistor output needs to be supplied with DC power, feed the power (+24 VDC; allowable range: +22 to +27 VDC, 100 mA max.) through the [PLC] terminal. Short-circuit between the terminals [CMY] and [CM] in this case.</li> </ul>																								
[CMY]	Transistor output common	<p>Common terminal for transistor output signals</p> <p>This terminal is electrically isolated from terminals [CM] and [11]s.</p>																								
<p><b>Tip</b> ■ Connecting programmable logic controller (PLC) to terminal [Y1], [Y2], [Y3] or [Y4]</p> <p>Figure 3.11 shows two examples of circuit connection between the transistor output of the inverter's control circuit and a PLC. In example (a), the input circuit of the PLC serves as a SINK for the control circuit output, whereas in example (b), it serves as a SOURCE for the output.</p>																										

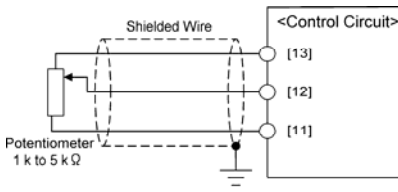
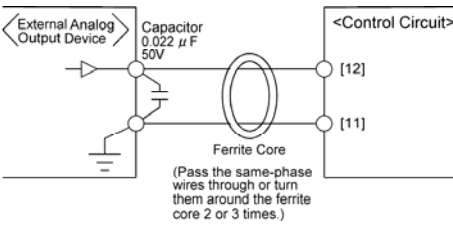
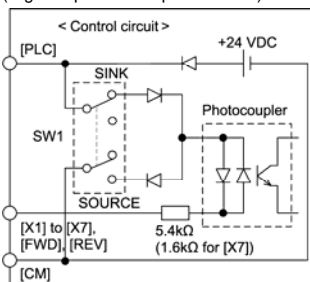
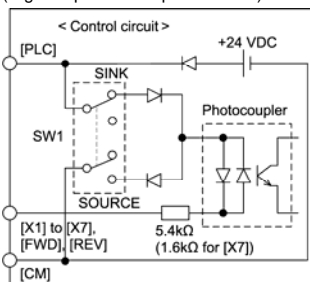
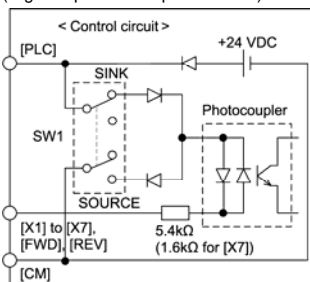
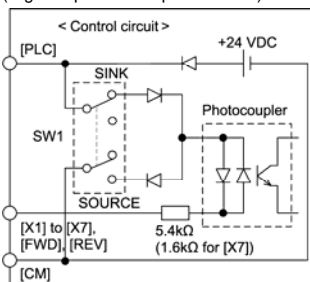
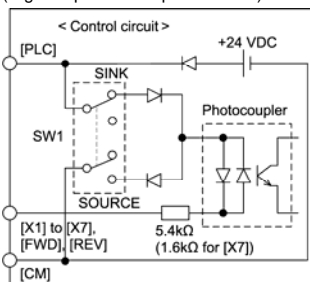
Table 3.3 Symbols, Names and Functions of the Control Circuit Terminals (Continued)

Classification	Symbol	Name	Functions
Transistor output			
	(a)	PLC serving as SINK	(b)
Relay output	[Y5A/C]	General purpose relay output	<p>(1) A general-purpose relay contact output usable as well as the function of the transistor output terminal [Y1], [Y2], [Y3] or [Y4]. Contact rating: <b>250 VAC, 0.3 A, <math>\cos \phi = 0.3</math></b>, <b>48 VDC, 0.5 A</b></p> <p>(2) Switching of the normal/negative logic output is applicable to the following two contact output modes: "Active ON" (Terminals [Y5A] and [Y5C] are closed (excited) if the signal is active.) and "Active OFF" (Terminals [Y5A] and [Y5C] are opened (non-excited) if the signal is active while they are normally closed.).</p>
	[30A/B/C]	Alarm relay output (for any error)	<p>(1) Outputs a contact signal (SPDT) when a protective function has been activated to stop the motor. Contact rating: <b>250 VAC, 0.3A, <math>\cos \phi = 0.3</math></b>, <b>48 VDC, 0.5A</b></p> <p>(2) Any one of output signals assigned to terminals [Y1] to [Y4] can also be assigned to this relay contact to use it for signal output.</p> <p>(3) Switching of the normal/negative logic output is applicable to the following two contact output modes: "Active ON" (Terminals [30A] and [30C] are closed (excited) if the signal is active.) and "Active OFF" (Terminals [30A] and [30C] are opened (non-excited) if the signal is active while they are normally closed.).</p>
Communications	[DX+]/ [DX-]/ [SD]	RS-485 communications port 2 (Terminals on control PCB)	<p>A communications port transmits data through the RS-485 multipoint protocol between the inverter and a personal computer or other equipment such as a PLC. (For setting of the termination resistor, refer to Section 3.4 "Setting up the slide switches.")</p>
	RJ-45 connector for the keypad	RS-485 communications port 1 (Standard RJ-45 connector)	<p>(1) Used to connect the inverter with the keypad. The inverter supplies the power to the keypad through the pins specified below. The extension cable for remote operation also uses wires connected to these pins for supplying the keypad power.</p> <p>(2) Remove the keypad from the standard RJ-45 connector and connect the RS-485 communications cable to control the inverter through the PC or PLC (Programmable Logic Controller). For setting of the termination resistor, refer to Section 3.4 "Setting up the slide switches."</p>
	USB connector	USB port (On the keypad)	<p>A USB port connector (Mini-B) that connects an inverter to a personal computer. FRENIC Loader software running on the computer supports editing the function codes, transferring them to the inverter, verifying them, test-running an inverter and monitoring the inverter running status.</p>

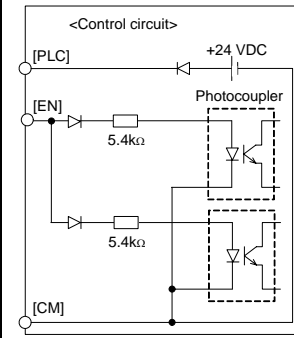
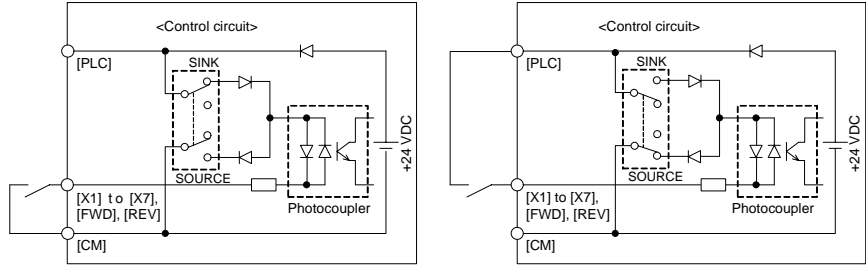
- Note**
- Route the wiring of the control circuit terminals as far from the wiring of the main circuit as possible. Otherwise electric noise may cause malfunctions.
  - Fix the control circuit wires with a cable tie inside the inverter to keep them away from the live parts of the main circuit (such as the terminal block of the main circuit).

### 3.4 Setting up the slide switches

Switching the slide switches located on the control PCB allows you to customize the operation mode of the analog output terminals, digital I/O terminals, and communications ports. The locations of those switches are shown in Figure 3.13.

To access the slide switches, remove the front cover so that you can see the control PCB. For inverters with a capacity of 30 kW or above, open also the keypad enclosure.

 For details on how to remove the front cover and how to open and close the keypad enclosure, refer to Section 3.1 "Removing and mounting the front cover and the wiring guide."

Table 3.4 lists function of each slide switch.

Table 3.4 Function of Each Slide Switch

Switch	Function																			
SW1	Switches the service mode of the digital input terminals between SINK and SOURCE. <ul style="list-style-type: none"> <li>This switches the input mode of digital input terminals [X1] to [X7], [FWD] and [REV] to be used as SINK or SOURCE mode.</li> <li>The factory default for FRN_ _ _G1■-2A/4A is SINK, for FRN_ _ _G1■-4E, SOURCE.</li> </ul>																			
SW2	Switches the termination resistor of RS-485 communications port on the inverter ON and OFF. (RS-485 communications port 2, on the control PCB) <ul style="list-style-type: none"> <li>If the inverter is connected to the RS-485 communications network as a termination device, turn SW2 to ON.</li> </ul>																			
SW3	Switches the termination resistor of RS-485 communications port on the inverter ON and OFF. (RS-485 communications port 1, for connecting the keypad) <ul style="list-style-type: none"> <li>To connect a keypad to the inverter, turn SW3 to OFF. (Factory default)</li> <li>If the inverter is connected to the RS-485 communications network as a termination device, turn SW3 to ON.</li> </ul>																			
SW4/SW6	Switches the output form of analog output terminals [FM1] and [FM2] between voltage and current. When changing the setting of SW4 and SW6, also change the data of function codes F29 and F32, respectively. <table border="1" style="width: 100%; border-collapse: collapse;"> <thead> <tr> <th rowspan="2">Output form</th> <th colspan="2">[FM1]</th> <th colspan="2">[FM2]</th> </tr> <tr> <th>SW4</th> <th>Data of F29</th> <th>SW6</th> <th>Data of F32</th> </tr> </thead> <tbody> <tr> <td>Voltage output (Factory default)</td> <td>VO1</td> <td>0</td> <td>VO2</td> <td>0</td> </tr> <tr> <td>Current output</td> <td>IO1</td> <td>1</td> <td>IO2</td> <td>1</td> </tr> </tbody> </table>	Output form	[FM1]		[FM2]		SW4	Data of F29	SW6	Data of F32	Voltage output (Factory default)	VO1	0	VO2	0	Current output	IO1	1	IO2	1
Output form	[FM1]		[FM2]																	
	SW4	Data of F29	SW6	Data of F32																
Voltage output (Factory default)	VO1	0	VO2	0																
Current output	IO1	1	IO2	1																
SW5	Switches the property of the analog input terminal [C1] between analog setting current input, PTC thermistor input, and NTC thermistor input. When changing this switch setting, also change the data of function code H26. <table border="1" style="width: 100%; border-collapse: collapse;"> <thead> <tr> <th>Function</th> <th>SW5</th> <th>Data of H26</th> </tr> </thead> <tbody> <tr> <td>Analog setting current input (Factory default)</td> <td>C1</td> <td>0</td> </tr> <tr> <td>PTC thermistor input</td> <td>PTC/NTC</td> <td>1 (alarm) or 2 (warning)</td> </tr> <tr> <td>NTC thermistor input</td> <td>PTC/NTC</td> <td>3</td> </tr> </tbody> </table>	Function	SW5	Data of H26	Analog setting current input (Factory default)	C1	0	PTC thermistor input	PTC/NTC	1 (alarm) or 2 (warning)	NTC thermistor input	PTC/NTC	3							
Function	SW5	Data of H26																		
Analog setting current input (Factory default)	C1	0																		
PTC thermistor input	PTC/NTC	1 (alarm) or 2 (warning)																		
NTC thermistor input	PTC/NTC	3																		

Figure 3.13 shows the location of slide switches on the control PCB for the input/output terminal configuration.

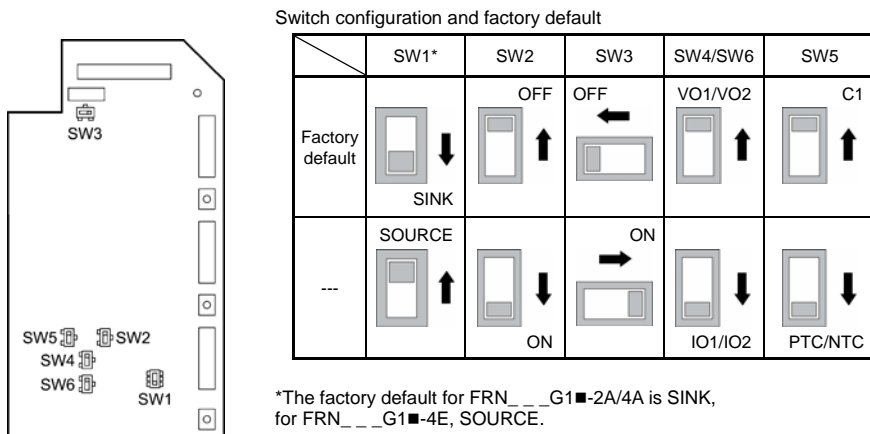



Figure 3.13 Location of the Slide Switches on the Control PCB

 **Note** To move a switch slider, use a tool with a narrow tip. If the slider is in an ambiguous position, the circuit is unclear whether it is turned ON or OFF and the digital input remains in an undefined state. Be sure to place the slider so that it contacts either side of the switch.

## Chapter 4 OPERATION USING THE KEYPAD

### 4.1 LED Monitor, Keys and LED Indicators on the Keypad

As shown at the right, the keypad consists of a four-digit LED monitor, six keys, and five LED indicators.

The keypad allows you to run and stop the motor, monitor the running status, specify the function code data, and monitor I/O signal states, maintenance information, and alarm information.

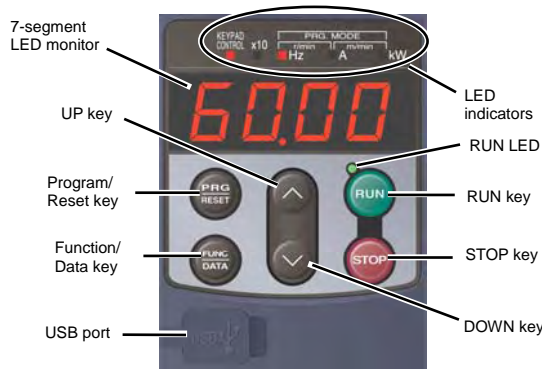

Table 4.1 Overview of Keypad Functions

Item	LED Monitor, Keys, and LED Indicators	Functions
LED Monitor		<p>Four-digit, 7-segment LED monitor which displays the followings according to the operation modes.</p> <ul style="list-style-type: none"> <li>■ In Running mode: Running status information (e.g., output frequency, current, and voltage) When a light alarm occurs, <i>-a/</i> is displayed.</li> <li>■ In Programming mode: Menus, function codes and their data</li> <li>■ In Alarm mode: Alarm code, which identifies the alarm factor when the protective function is activated.</li> </ul>
Operation Keys		<p>Program/Reset key which switches the operation modes of the inverter.</p> <ul style="list-style-type: none"> <li>■ In Running mode: Pressing this key switches the inverter to Programming mode.</li> <li>■ In Programming mode: Pressing this key switches the inverter to Running mode.</li> <li>■ In Alarm mode: Pressing this key after removing the alarm factor will switch the inverter to Running mode.</li> </ul>
		<p>Function/Data key which switches the operations you want to do in each mode as follows:</p> <ul style="list-style-type: none"> <li>■ In Running mode: Pressing this key switches the information to be displayed concerning the status of the inverter (output frequency (Hz), output current (A), output voltage (V), etc.) When a light alarm is displayed, holding down this key resets the light alarm and switches back to Running mode.</li> <li>■ In Programming mode: Pressing this key displays the function code or establishes the data entered with  and  keys.</li> <li>■ In Alarm mode: Pressing this key displays the details of the problem indicated by the alarm code that has come up on the LED monitor.</li> </ul>
		RUN key. Press this key to run the motor.
		STOP key. Press this key to stop the motor.
		UP and DOWN keys. Press these keys to select the setting items and change the function code data displayed on the LED monitor.
LED Indicators	RUN LED	Lights when running with a run command entered by the  key, by terminal command <i>FWD</i> or <i>REV</i> , or through the communications link.
	KEYPAD CONTROL LED	Lights when the inverter is ready to run with a run command entered by the  key (F02 = 0, 2, or 3). In Programming and Alarm modes, however, pressing the  key cannot run the inverter even if this indicator lights.
	Unit LEDs (3 LEDs)	<p>These three LED indicators identify the unit of numeral displayed on the LED monitor in Running mode by combination of lit and unlit states of them. Unit: Hz, A, kW, r/min and m/min Refer to Chapter 3, Section 3.3.1 "Monitoring the running status" for details.</p> <p>While the inverter is in Programming mode, the LEDs of Hz and kW light.</p> <p>■ Hz □ A ■ kW</p>
	x10 LED	Lights when the data to display exceeds 9999. When this LED lights, the "displayed value x 10" is the actual value. Example: If the LED monitor displays 1234 and the x10 LED lights, it means that the actual value is "1,234 × 10 = 12,340."
USB port		The USB port with a Mini-B connector enables the inverter to connect with a PC with a USB cable.

## 4.2 Overview of Operation Modes

FRENIC-MEGA features the following three operation modes.

Table 4.2 Operation Modes

Operation mode	Description
Running mode	After powered ON, the inverter automatically enters this mode. This mode allows you to specify the reference frequency, PID command value and etc., and run/stop the motor with the  /  keys. It is also possible to monitor the running status in real time. If a light alarm occurs, the <i>l-al</i> appears on the LED monitor.
Programming mode	This mode allows you to configure function code data and check a variety of information relating to the inverter status and maintenance.
Alarm mode	If an alarm condition arises, the inverter automatically enters Alarm mode in which you can view the corresponding alarm code* and its related information on the LED monitor. * Alarm code: Indicates the cause of the alarm condition. For details, first see Table 6.1 "Abnormal States Detectable ("Heavy Alarm" and "Light Alarm" Objects)" in Chapter 6, Section 6.1 "Protective Functions," and then read the troubleshooting of each alarm.

Figure 4.1 shows the status transition of the inverter between these three operation modes.

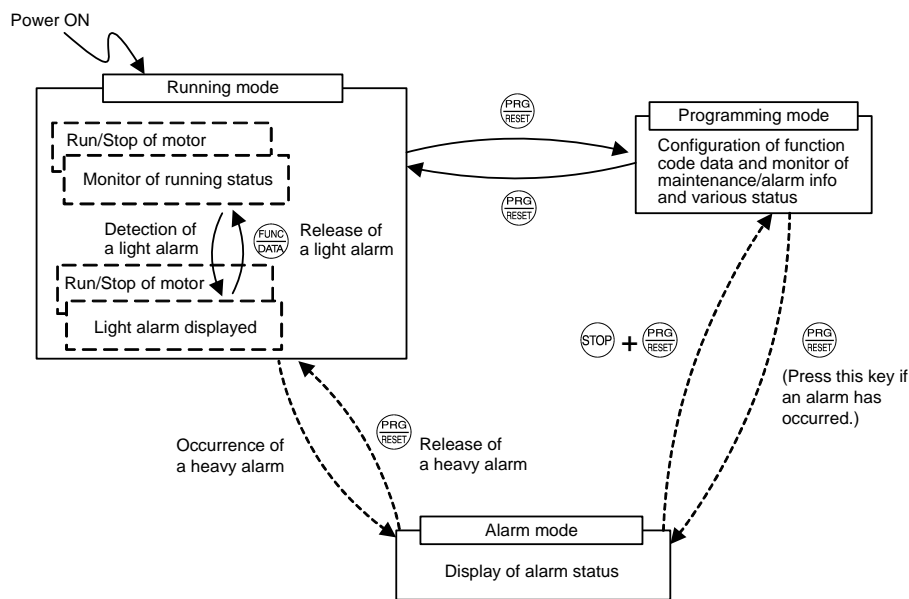

Figure 4.1 Status Transition between Operation Modes

### Tip Simultaneous keying

Simultaneous keying means pressing two keys at the same time. The simultaneous keying operation is expressed by a "+" letter between the keys throughout this manual.

For example, the expression " + keys" stands for pressing the key with the key held down.

## 4.3 USB Connectivity

The keypad has an USB port ( Mini-B connector) on its face. To connect an USB cable, open the USB port cover as shown below.



Connecting the inverter to a PC with an USB cable enables remote control from FRENIC Loader. On the PC running FRENIC Loader, it is possible to edit, check, manage, and monitor the function code data in real-time, to start or stop the inverter, and to monitor the running or alarm status of the inverter.

For the instructions on how to use the FRENIC Loader, refer to the FRENIC Loader Instruction Manual.

In addition, using the keypad as a temporary storage media allows you to store the running status information in the keypad, detach the keypad from the inverter, connect it to a PC running FRENIC Loader at an office or off-site place.

## Chapter 5 QUICK START COMMISSIONING

### 5.1 Checking prior to powering on

Check the following before powering on the inverter.

- (1) Check that the wiring is correct.

Especially check the wiring to the inverter input terminals L1/R, L2/S and L3/T and output terminals U, V, and W. Also check that the grounding wires are connected to the grounding terminals (⊕G) correctly. See Figure 5.1.

<b>⚠ WARNING</b>
<ul style="list-style-type: none"> <li>Never connect power supply wires to the inverter output terminals U, V, and W. Doing so and turning the power ON breaks the inverter.</li> <li>Be sure to connect the grounding wires of the inverter and the motor to the ground electrodes. <b>Otherwise, an electric shock could occur.</b></li> </ul>

- (2) Check the control circuit terminals and main circuit terminals for short circuits or ground faults.
- (3) Check for loose terminals, connectors and screws.
- (4) Check that the motor is separated from mechanical equipment.
- (5) Make sure that all switches of devices connected to the inverter are turned OFF. Powering on the inverter with any of those switches being ON may cause an unexpected motor operation.
- (6) Check that safety measures are taken against runaway of the equipment, e.g., a defense to prevent people from access to the equipment.

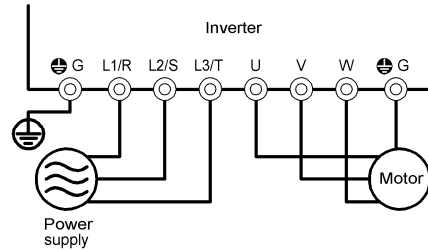

Figure 5.1 Connection of Main Circuit Terminals

### 5.2 Powering ON and checking

<b>⚠ WARNING</b>
<ul style="list-style-type: none"> <li>Be sure to mount the front cover before turning the power ON. Do not remove the cover when the inverter power is ON.</li> <li>Do not operate switches with wet hands. <b>Otherwise, an electric shock could occur.</b></li> </ul>

Turn the power ON and check the following points. The following is a case when no function code data is changed from the factory defaults.

- (1) Check that the LED monitor displays \*00 (indicating that the reference frequency is 0 Hz) that is blinking. (See Figure 5.2.)  
If the LED monitor displays any number except \*00, press  $\uparrow$  /  $\downarrow$  key to set \*00.
- (2) Check that the built-in cooling fans rotate.  
(Inverters with a capacity of 1.5 kW or below are not equipped with a cooling fan.)



Figure 5.2 Display of the LED Monitor after Power-on

### 5.3 Switching between HD and LD drive modes

The FRENIC-MEGA series of inverters is applicable to two ratings: high duty (HD) for heavy load applications and low duty (LD) for light load ones. Function code F80 switches the FRENIC-MEGA between the HD and LD modes.

F80 data	Drive mode	Application	Continuous current rating level	Overload capability	Maximum frequency
0	HD (High Duty) mode (default)	Heavy load	Capable of driving a motor whose capacity is the <u>same</u> as the inverter's one.	150% for 1 min. 200% for 3 s	500 Hz
1	LD (Low Duty) mode	Light load	Capable of driving a motor whose capacity is <u>one rank higher</u> than the inverter's one.	120% for 1 min.	120 Hz

In the LD-mode, inverter brings out the continuous current rating level which enables the inverter to drive a motor with one rank higher capacity, but its overload capability (%) against the continuous current level decreases. For the rated current level, see Chapter 8.

In the LD-mode, inverter is subjected to restrictions on the function code data setting range and internal processing as listed below.

Function codes	Name	HD mode	LD mode	Remarks
F 21*	DC braking (Braking level)	Setting range: 0 to 100%	Setting range: 0 to 80%	In the LD mode, a value out of the range, if specified, automatically changes to the maximum value allowable in the LD mode.
F 26	Motor sound (Carrier frequency)	Setting range: 0.75 to 16 kHz (0.4 to 22 kW) 0.75 to 16 kHz (30 to 55 kW) 0.75 to 10 kHz (75 to 630 kW)	Setting range: 0.75 to 16 kHz (0.4 to 18.5 kW) 0.75 to 10 kHz (22 to 55 kW) 0.75 to 6 kHz (75 to 630 kW)	

Function codes	Name	HD mode	LD mode	Remarks
F 44	Current limiter (Level)	Initial value: 160%	Initial value: 130%	Switching the drive mode between HD and LD with function code F80 automatically initializes the F44 data to the value specified at left.
F 03*	Maximum frequency	Setting range: 25 to 500 Hz Upper limit: 500 Hz	Setting range: 25 to 500 Hz Upper limit: 120 Hz	In the LD mode, if the maximum frequency exceeds 120 Hz, the actual output frequency is internally limited to 120 Hz.
—	Current indication and output	Based on the rated current level for HD mode	Based on the rated current level for LD mode	—

Switching to the LD mode does not automatically change the motor rated capacity (P02\*) to the one for the motor with one rank higher capacity, so configure the P02\* data to match the applied motor rating as required.

#### 5.4 Selecting the desired motor drive control

The FRENIC-MEGA supports the following motor drive control.

F42* data	Drive control	Basic control	Speed feedback	Speed control	Other restrictions
0	V/f control with slip compensation inactive	V/f control	Disable	Frequency control	—
1	Dynamic torque vector control			Frequency control with slip compensation	—
2	V/f control with slip compensation active			—	—
5	Vector control without speed sensor	Vector control	Estimated speed	Speed control with automatic speed regulator (ASR)	Maximum frequency: 120 Hz
6	Vector control with speed sensor		Enable		Maximum frequency: 200 Hz

##### ■ V/f control with slip compensation inactive

Under this control, the inverter controls a motor with the voltage and frequency according to the V/f pattern specified by function codes. This control disables all automatically controlled features such as the slip compensation, so there will not be any unpredictable output fluctuation, enabling stable operation with constant output frequency.

##### ■ V/f control with slip compensation active

Applying any load to an induction motor causes a rotational slip due to the motor characteristics, decreasing the motor rotation. The inverter's slip compensation function first presumes the slip value of the motor based on the motor torque generated and raises the output frequency to compensate for the decrease in motor rotation. This prevents the motor from decreasing the rotation due to the slip.

This function improves the motor speed control accuracy.

The compensation value is specified by combination of function codes P12\* (Rated slip frequency), P09\* (Slip compensation gain for driving) and P11\* (Slip compensation gain for braking).

H68\* enables or disables the slip compensation function according to the motor driving conditions.

H68* data	Motor driving conditions		Motor driving frequency zone	
	Accel/Decel	Constant speed	Base frequency or below	Above the base frequency
0	Enable	Enable	Enable	Enable
1	Disable	Enable	Enable	Enable
2	Enable	Enable	Enable	Disable
3	Disable	Enable	Enable	Disable

##### ■ Dynamic torque vector control

To get the maximal torque out of a motor, this control calculates the motor torque for the load applied and uses it to optimize the voltage and current vector output.

Selecting this control automatically enables the auto torque boost and slip compensation function.

This control improves the system response to external disturbances such as load fluctuation, and the motor speed control accuracy.

Note that the inverter may not respond to a rapid load fluctuation since this control is an open-loop V/f control that does not perform the current control, unlike the vector control. The advantages of this control include larger maximum torque per output current than that the vector control.

##### ■ Vector control without speed sensor

This control estimates the motor speed based on the inverter's output voltage and current to use the estimated speed for speed control. In addition, it decomposes the motor drive current into the exciting and torque current components, and controls each of those components in vector. No PG (pulse generator) interface card is required. It is possible to obtain the desired response by adjusting the control constants (PI constants) using the speed regulator (PI controller).

Since this control controls the motor current, it is necessary to secure some voltage margin between the voltage that the inverter can output and the induced voltage of the motor, by keeping the former lower than the latter.

Although the voltage of the general-purpose motor has usually been adjusted to match the commercial power, keeping the motor terminal voltage low is necessary in order to secure the voltage margin. If the motor is driven under this control with the motor terminal voltage being kept low, however, the rated torque cannot be obtained even when the rated current originally specified for the motor is applied. To secure the rated torque, therefore, it is necessary to use a motor with higher rated current. (This also applies to the vector control with speed sensor.)

##### ■ Vector control with speed sensor

This control requires an optional PG (pulse generator) and an optional PG interface card to be mounted on the motor shaft and on the inverter, respectively. The inverter detects the motor's rotational position and speed from PG feedback signals and uses them for speed

control. In addition, it decomposes the motor drive current into the exciting and torque current components, and controls each of these components as vectors.

The desired response can be obtained by adjusting the control constants (PI constants) and using the speed regulator (PI controller). This control enables the speed control with higher accuracy and quicker response than the vector control without speed sensor.

## 5.5 Function code basic settings for F42=0, 1 or 2

Driving a motor under the V/f control (F42\* = 0 or 2) or dynamic torque vector control (F42\* = 1) requires configuring the following basic function codes. Configure the function codes listed below according to the motor ratings and your machinery design values. For the motor ratings, check the ratings printed on the motor's nameplate. For your machinery design values, ask system designers about them.

Function code	Name	Function code data	Factory default
			FRN___G1■-4E
F 04 *	Base frequency 1	Motor ratings (printed on the nameplate of the motor)	50.0 (Hz)
F 05 *	Rated voltage at base frequency 1		400 (V)
P 02 *	Motor 1 (Rated capacity)		Nominal applied motor capacity
P 03 *	Motor 1 (Rated current)		Rated current of nominal applied motor
F 03 *	Maximum frequency 1	Machinery design values (Note) For a test-driving of the motor, increase values so that they are longer than your machinery design values. If the specified time is short, the inverter may not run the motor properly.	50.0 (Hz)
F 07 *	Acceleration time 1 (Note)		6.00 (s)
F 08 *	Deceleration time 1 (Note)		6.00 (s)

**Note** When accessing the function code P02\*, take into account that changing the P02\* data automatically updates the data of the function codes P03\*, P06\* to P23\*, P53\* to P56\*, and H46. The full control performance may be obtained from the inverter when performing auto-tuning.

### ■ Tuning procedure

#### (1) Selection of tuning type

Check the situation of the machinery and select "Tuning with the motor being stopped (P04\* = 1)" or "Tuning with the motor running (P04\* = 2)." For the latter tuning, adjust the acceleration and deceleration times (F07\* and F08\*) and specify the rotation direction that matches the actual rotation direction of the machinery.



P04* data	Motor parameters subjected to tuning:	Tuning type	Selection condition of tuning type
1 Tune while the motor stops.	Primary resistance (%R1) (P07*) Leakage reactance (%X) (P08*) Rated slip frequency (P12*) %X correction factor 1 and 2 (P53* and P54*)	Tuning <u>with the motor being stopped</u> .	Cannot rotate the motor.
2 Tune while the motor is rotating under V/f control	No-load current (P06*) Primary resistance (%R1) (P07*) Leakage reactance (%X) (P08*) Rated slip frequency (P12*) Magnetic saturation factors 1 to 5 Magnetic saturation extension factors "a" to "c" (P16* to P23*) %X correction factor 1 and 2 (P53* and P54*)	Tuning the %R1 and %X, <u>with the motor being stopped</u> . Tuning the no-load current and magnetic saturation factor, <u>with the motor running</u> at 50% of the base frequency. Tuning the rated slip frequency, <u>with the motor being stopped</u> .	Can rotate the motor, provided that it is safe. The best tuning result is obtained when no load is applied to the motor during this procedure. Little load can be applied during tuning, but note that doing so decreases the tuning accuracy (the accuracy is worse as the load increases).

The tuning results of motor parameters will be automatically saved into their respective function codes. If P04\* tuning is performed, for instance, the tuning results will be saved into P codes (Motor 1 parameters).

#### (2) Preparation of machinery

Perform appropriate preparations on the motor and its load, such as disengaging the coupling from the motor and deactivating the safety devices.

#### (3) Tuning

- ① Set function code P04\* to "1" or "2" and press the  key. (The blinking of 1 or 2 on the LED monitor will slow down.)
- ② Enter a run command. The factory default is "  key on the keypad for forward rotation." To switch to reverse rotation or to select the terminal signal **FWD** or **REV** as a run command, change the data of function code F02.
- ③ At the moment that a run command is entered, the display of 1 or 2 lights up, and tuning starts with the motor being stopped. (Maximum tuning time: Approx. 40 s.)
- ④ If P04\* = 2, after the tuning in ③ above, the motor is accelerated to approximately 50% of the base frequency and then tuning starts. Upon completion of measurements, the motor will decelerate to a stop. (Estimated tuning time: Acceleration time + 20 s + Deceleration time)
- ⑤ If P04\* = 2, after the motor decelerates to a stop in ④ above, tuning will continue with the motor being stopped. (Maximum tuning time: Approx. 20 s.)
- ⑥ If the terminal signal **FWD** or **REV** is selected as a run command (F02 = 1), **end** will appear upon completion of the measurements. Turning the run command OFF completes the tuning.  
If the run command has been given through the keypad or the communications link, it automatically turns OFF upon completion of the measurements, which completes the tuning.
- ⑦ Upon completion of the tuning, the subsequent function code P06\* appears on the keypad.

## ■ Tuning errors

Improper tuning would negatively affect the operation performance and, in the worst case, could even cause hunting or deteriorate precision. Therefore, if the inverter finds any abnormality in the tuning results or any error in the tuning process, it displays *er7* and discards the tuning data. Listed below there are possible causes that trigger tuning errors.

Possible tuning error causes	Details
Error in tuning results	- An interphase voltage unbalance or output phase loss has been detected. - Tuning has resulted in an abnormally high or low value of a parameter due to the output circuit opened.
Output current error	An abnormally high current has flown during tuning.
Sequence error	During tuning, a run command has been turned OFF, or <b>STOP</b> (Force to stop), <b>BX</b> (Coast to a stop), <b>DWP</b> (Protect from dew condensation), or other similar terminal command has been received.
Error due to limitation	- During tuning, any of the operation limiters has been activated. - The maximum frequency or the frequency limiter (high) has limited tuning operation.
Other errors	An undervoltage or any other alarm has occurred.

If any of these errors occurs, remove the error cause and perform tuning again, or consult your Fuji Electric representative.

**Note** If an output filter is connected to the inverter's output (secondary) circuit, the tuning result cannot be assured. When replacing the inverter connected with such a filter, make a note of the old inverter's settings for the primary resistance %R1, leakage reactance %X, no-load current, and rated slip frequency, and specify those values to the new inverter's function codes.

Vibration that may occur when the motor's coupling is elastic can be regarded as normal vibration due to the output voltage pattern applied in tuning. The tuning does not always result in an error; however, run the motor and check its running state.

## 5.6 Function code basic settings for F42=5

Driving a motor under vector control without speed sensor (F42\* = 5) requires auto tuning.

Configure the function codes listed below according to the motor ratings and your machinery design values. For the motor ratings, check the ratings printed on the motor's nameplate. For your machinery design values, ask system designers about them.

Function code	Name	Function code data	Factory default
			FRN__ _G1■-4E
F 04 *	Base frequency 1	Motor ratings (printed on the nameplate of the motor)	50.0 (Hz)
F 05 *	Rated voltage at base frequency 1		400 (V)
P 02 *	Motor 1 (Rated capacity)		Nominal applied motor capacity
P 03 *	Motor 1 (Rated current)		Rated current of nominal applied motor
F 03 *	Maximum frequency 1	Machinery design values (Note) For a test-driving of the motor, increase values so that they are longer than your machinery design values. If the specified time is short, the inverter may not run the motor properly.	50.0 (Hz)
F 07 *	Acceleration time 1 (Note)		6.00 (s)
F 08 *	Deceleration time 1 (Note)		6.00 (s)

- Note**
- When accessing the function code P02\*, take into account that changing the P02\* data automatically updates the data of the function codes P03\*, P06\* to P23\*, P53\* to P56\*, and H46.
  - Specify the rated voltage at base frequency (F05) at the normal value, although the inverter controls the motor keeping the rated voltage (rated voltage at base frequency) low under vector control without speed sensor. After the auto tuning, the inverter automatically reduces the rated voltage at base frequency.

## ■ Tuning procedure

### (1) Selection of tuning type

Check the machinery conditions and perform the "tuning while the motor is rotating under vector control" (P04\*=3). Adjust the acceleration and deceleration times (F07\* and F08\*) in view of the motor rotation. And specify the rotation direction that matches the actual rotation direction of the machinery.

**Note** If the "tuning while the motor is rotating under vector control (P04\*=3)" cannot be selected due to restrictions on the machinery, refer to the "■ If tuning while the motor is rotating cannot be selected" below.

P04* data	Motor parameters subjected to tuning:	Tuning type	Selection condition of tuning type	Drive control		
				V/f	w/o PG	w/ PG
1	Primary resistance (%R1) (P07*) Leakage reactance (%X) (P08*) Rated slip frequency (P12*) %X correction factor 1 and 2 (P53* and P54*)	Tuning <u>with the motor being stopped</u> .	Cannot rotate the motor.	Y	Y*	Y*
2	No-load current (P06*) Primary resistance (%R1) (P07*) Leakage reactance (%X) (P08*) Rated slip frequency (P12*) Magnetic saturation factors 1 to 5 Magnetic saturation extension factors "a" to "c" (P16* to P23*) %X correction factor 1 and 2 (P53* and P54*)	Tuning the %R1 and %X, <u>with the motor being stopped</u> . Tuning the no-load current and magnetic saturation factor, <u>with the motor running</u> at 50% of the base frequency. Tuning the rated slip frequency again, <u>with the motor being stopped</u> .	Can rotate the motor, provided that it is safe. The best tuning result is obtained when no load is applied to the motor during this procedure. Little load can be applied during tuning, but note that doing so decreases the tuning accuracy (the accuracy is worse as the load increases).	Y	N	N

P04* data	Motor parameters subjected to tuning:	Tuning type	Selection condition of tuning type	Drive control		
				V/f	w/o PG	w/ PG
3	No-load current (P06*) Primary resistance (%R1) (P07*) Leakage reactance (%X) (P08*) Rated slip frequency (P12*) Magnetic saturation factors 1 to 5 Magnetic saturation extension factors "a" to "c" (P16* to P23*) %X correction factor 1 and 2 (P53* and P54*)	Tuning the %R1, %X and rated slip frequency, <u>with the motor being stopped</u> . Tuning the no-load current and magnetic saturation factor, <u>with the motor running</u> at 50% of the base frequency twice.	Can rotate the motor, provided that it is safe. The best tuning result is obtained when no load is applied to the motor during this procedure. Little load can be applied during tuning, but note that doing so decreases the tuning accuracy (the accuracy is worse as the load increases).	N	Y	Y

Drive control abbreviation: "V/f" (V/f control), "w/o PG" (vector control without speed sensor) and "w/ PG" (vector control with speed sensor)



Y: Tuning available unconditionally Y\*: Tuning available conditionally N: Tuning not available

The tuning results of motor parameters will be automatically saved into their respective function codes. If P04\* tuning is performed, for instance, the tuning results will be saved into P codes (Motor 1 parameters).

## (2) Preparation of machinery

Perform appropriate preparations on the motor and its load, such as disengaging the coupling from the motor and deactivating the safety devices.

## (3) Tuning (Tune while the motor is rotating under vector control)

- ① Set function code P04\* to "3" and press the  key. (The blinking of 3 on the LED monitor will slow down.)
- ② Enter a run command. The factory default is "  key on the keypad for forward rotation." To switch to reverse rotation or to select the terminal signal **FWD** or **REV** as a run command, change the data of function code F02.
- ③ At the moment that a run command is entered, the display of 3 lights up, and tuning starts with the motor being stopped. (Maximum tuning time: Approx. 40 s.)
- ④ Next, the motor is accelerated to approximately 50% of the base frequency and then tuning starts. Upon completion of measurements, the motor will decelerate to a stop. (Estimated tuning time: Acceleration time + 20 s + Deceleration time)
- ⑤ After the motor decelerates to a stop in ④ above, tuning will continue with the motor being stopped. (Maximum tuning time: Approx. 20 s.)
- ⑥ The motor is again accelerated to approximately 50% of the base frequency and then tuning starts. Upon completion of measurements, the motor will decelerate to a stop. (Estimated tuning time: Acceleration time + 20 s + Deceleration time)
- ⑦ After the motor decelerates to a stop in ⑥ above, tuning will continue with the motor being stopped. (Maximum tuning time: Approx. 20 s.)
- ⑧ If the terminal signal **FWD** or **REV** is selected as a run command (F02 = 1), *end* will appear upon completion of the measurements. Turning the run command OFF completes the tuning.  
If the run command has been given through the keypad or the communications link, it automatically turns OFF upon completion of the measurements, which completes the tuning.
- ⑨ Upon completion of the tuning, the subsequent function code P06\* appears on the keypad.

### ■ If tuning while the motor is rotating cannot be selected

If the "tuning while the motor is rotating under vector control (P04\*=3)" cannot be selected due to restrictions on the machinery, perform the "tuning with the motor stops (P04\*=1)" by following the procedure below. Compared to the former tuning, the latter may show rather inferior performance in the speed control accuracy or stability, perform sufficient tests beforehand by connecting the motor with the machinery.

- ① Specify the F04\*, F05\*, P02\*, and P03\* data according to the motor rated values printed on the motor's nameplate.
- ② Specify motor ratings (the data of P06\*, P16\* to P23\*) by obtaining the appropriate values on the datasheet issued from the motor manufacturer.  
For details of conversion from data on the datasheet into ones to be entered as function code data, contact your Fuji Electric representative.
- ③ Perform the "tuning with the motor stops (P04\*=1)."

## 5.7 Function code basic settings for F42=6

Driving a motor under the vector control with speed sensor (F42\* = 6) requires configuring the following additional (to the case F42=5) function codes.

Function code	Name	Function code data	Factory default
			FRN__ _G1■-4E
H 26	Thermistor (for motor) (Mode selection)	3: Enable (when NTC thermistor) Also turn SW5 on the control printed circuit board to the PTC/NTC side.	0: Disable
d 14	Feedback input (Pulse train input)	2: A/B phase with 90 degree phase shift	2: A/B phase
d 15	Feedback input (Encoder pulse resolution)	0400hex (1024)	0400hex (1024)
F 11*	Electric thermal overload protection for motor 1 (Overload detection level)	0.00: Disable	Depending upon the inverter capacity

## 5.8 Running the inverter for motor operation check

<b>⚠ WARNING</b>
If the user configures the function codes wrongly without completely understanding this Instruction Manual and the FRENIC-MEGA User's Manual, the motor may rotate with a torque or at a speed not permitted for the machine. <b>Accident or injury may result.</b>

After completion of preparations for a test run as described above, start running the inverter for motor operation check using the following procedure.

<b>⚠ CAUTION</b>
If any abnormality is found in the inverter or motor, immediately stop operation and investigate the cause referring to Chapter 7.

### ----- Test Run Procedure -----

- (1) Turn the power ON and check that the reference frequency \*00 Hz is blinking on the LED monitor.
- (2) Set a low reference frequency such as 5 Hz, using  $\wedge$  /  $\vee$  keys. (Check that the frequency is blinking on the LED monitor.)
- (3) Press the  $\text{RUN}$  key to start running the motor in the forward direction. (Check that the reference frequency is displayed on the LED monitor.)
- (4) To stop the motor, press the  $\text{STOP}$  key.

#### < Check points during a test run >

- Check that the motor is running in the forward direction.
- Check for smooth rotation without motor humming or excessive vibration.
- Check for smooth acceleration and deceleration.

When no abnormality is found, press the  $\text{RUN}$  key again to start driving the motor, then increase the reference frequency using  $\wedge$  /  $\vee$  keys. Check the above points again.

If any problem is found, modify the function code data again as described below.

**Tip** Depending on the settings of function codes, the motor speed may rise to an unexpectedly high and dangerous level, particularly, under vector control with/without speed sensor. To avoid such an event, the speed limiting function is provided. If the user is unfamiliar with the function code settings (e.g., when the user starts up the inverter for the first time), it is recommended that the frequency limiter (high) (F15) and the torque control (speed limit 1/2) (d32/d33) be used. At the startup of the inverter, to ensure safer operation, specify small values to those function codes at first and gradually increase them while checking the actual operation.

The speed limiting function serves as an overspeed level barrier, or as a speed limiter under torque control. For details of the speed limiting function, refer to the FRENIC-MEGA User's Manual.

The vector control uses a PI controller for speed control. The PI constants are sometimes required to be modified because of the load inertia. The table below lists the main modification items.

Function code	Name	Modification key points
d 01	Speed control (Speed command filter)	If an excessive overshoot occurs for a speed command change, increase the filter constant.
d 02	Speed control (Speed detection filter)	If ripples are superimposed on the speed detection signal so that the speed control gain cannot be increased, increase the filter constant to obtain a larger gain.
d 03	Speed control P (Gain)	If hunting is caused in the motor speed control, decrease the gain. If the motor response is slow, increase the gain.
d 04	Speed control I (Integral time)	If the motor response is slow, decrease the integral time.

## 5.9 Preparation for practical operation

After verifying normal motor running with the inverter in a test run, connect the motor with the machinery and perform wiring for practical operation.

- (1) Configure the application related function codes that operate the machinery.
- (2) Check interfacing with the peripheral circuits.
  - 1) Mock alarm. Generate a mock alarm by pressing the  $\text{STOP}$  +  $\text{ALARM}$  keys" on the keypad for 5 seconds or more and check the alarm sequence. The inverter should stop and issue an alarm output signal (for any fault).
  - 2) Judgment on the life of the DC link bus capacitor. When the multi-function keypad is used, it is necessary to set up the judgment reference level to be applied for the judgment on the life of the DC link bus capacitor. When the remote keypad is used, the same setting-up is also necessary in order to judge the life of the DC link bus capacitor under the practical operating conditions. For details, refer to Chapter 7 of the Instruction Manual.
  - 3) I/O checking. Check interfacing with peripherals using Menu #4 "I/O Checking" on the keypad in Programming mode.
  - 4) Analog input adjustment. Adjust the analog inputs on terminals [12], [C1] and [V2] using the function codes related to the offset, filter and gain that minimize analog input errors. For details, refer to Chapter 6.
  - 5) Calibrating the [FM] output. Calibrate the full scale of the analog meter connected to the terminals [FM1] and [FM2], using the reference voltage equivalent to +10 VDC. To output the reference voltage, it is necessary to select the analog output test with the function code (F31/F35 = 14).
  - 6) Clearing the alarm history. Clear the alarm history saved during the system setup with the function code (H97 = 1).

**Note** Depending upon the situation of the practical operation, it may become necessary to modify the settings of the torque boost (F09\*), acceleration/deceleration times (F07\*/F08\*), and the PI controller for speed control under the vector control. Confirm the function code data and modify them properly.

## Chapter 6 FUNCTION CODES

### 6.1 Function Code Tables

Each function code consists of a 3-character alphanumeric string. The first character is a letter that identifies its group and the following two characters are digits that identify each individual code in the group. The function codes are classified into twelve groups: Fundamental Functions (F codes), Extension Terminal Functions (E codes), Control Functions (C codes), Motor 1 Parameters (P codes), High Performance Functions (H codes), Motor 2, 3 and 4 Parameters (A, b and r codes), Application Functions 1 and 2 (J and d codes), Link Functions (y codes) and Option Functions (o codes). To determine the property of each function code, set data to the function code. This manual does not contain the descriptions of Option Function (o codes). For Option Function (o codes), refer to the instruction manual for each option.

The negative logic signaling can be used for the digital input and output terminals. To set the negative logic to an I/O terminal, enter data of 1000s (by adding 1000 to the data for the normal logic) in the corresponding function code.

Example: "Coast to a stop" command **BX** assigned to any of digital input terminals [X1] to [X7] (using any of function codes E01 to E07).

Function code data	Description
7	Turning <b>BX</b> ON causes the motor to coast to a stop (Active-ON).
1007	Turning <b>BX</b> OFF causes the motor to coast to a stop (Active-OFF).

Some signals cannot switch to active-OFF depending upon their assigned functions.

The following tables list the function codes available for the FRENIC-MEGA series of inverters.

#### F codes: fundamental functions

Code	Name	Data setting range	Default setting
F00	Data Protection	0 to 3	0
F01	Frequency Command 1	0: Keypad 1: Voltage input to terminal [12] (-10 to +10 VDC) 2: Current input to terminal [C1] (4 to 20 mA DC) 3: Sum of voltage and current inputs to terminals [12] and [C1] 5: Voltage input to terminal [V2] (0 to 10 VDC) 7: Terminal command <b>UP/DOWN</b> control 8: Keypad (balanceless-bumpless switching available) 11: Digital input interface card (option) 12: PG interface card	0
F02	Operation Method	0 to 3	2
F03	Maximum Frequency 1	25.0 to 500.0 Hz	50.0
F04	Base Frequency 1	25.0 to 500.0 Hz	50.0
F05	Rated Voltage at Base Frequency 1	0: Output a voltage in proportion to input voltage 160 to 500 V: Output an AVR-controlled voltage	400
F06	Maximum Output Voltage 1	160 to 500 V: Output an AVR-controlled voltage	400
F07	Acceleration Time 1	0.00 to 6000 s	*1
F08	Deceleration Time 1	Note: Entering 0.00 cancels the acceleration time, requiring external soft-start.	*1
F09	Torque Boost 1	0.0% to 20.0% (percentage with respect to F05 value)	*2
F10	Electronic Thermal Overload Protection for Motor 1 (Select motor characteristics)	1: For a general-purpose motor with shaft-driven cooling fan 2: For an inverter-driven motor, non-ventilated motor, or motor with separately powered cooling fan	1
F11	(Overload detection level)	0.00: Disable; 1% to 135% of the rated current (allowable continuous drive current) of the motor	*3
F12	(Thermal time constant)	0.5 to 75.0 min	*4
F14	Restart Mode after Momentary Power Failure (Mode selection)	0 to 5	1
F15	Frequency Limiter (High)	0.0 to 500.0 Hz	70.0
F16	Frequency Limiter (Low)	0.0 to 500.0 Hz	0.0
F18	Bias (Frequency command 1)	-100.00% to 100.00%	0.00
F20	DC Braking 1 (Braking starting frequency)	0.0 to 60.0 Hz	0.0
F21	(Braking level)	0% to 100% (HD mode), 0% to 80% (LD mode)	0
F22	(Braking time)	0.00 (Disable); 0.01 to 30.00 s	0.00
F23	Starting Frequency 1	0.0 to 60.0 Hz	0.5
F24	(Holding time)	0.00 to 10.00 s	0.00
F25	Stop Frequency	0.0 to 60.0 Hz	0.2
F26	Motor Sound (Carrier frequency)	0.75 to 16 kHz (HD-mode inverters with 55 kW or below and LD-mode ones with 18.5 kW or below) 0.75 to 10 kHz (HD-mode inverters with 75 to 630 kW and LD-mode ones with 22 to 55 kW); 0.75 to 6 kHz (LD-mode inverters with 75 to 630 kW)	2
F27	(Tone)	0 to 3	0
F29	Analog Output [FM1] (Mode selection)	0: Output in voltage (0 to 10 VDC); 1: Output in current (4 to 20 mA DC)	0
F30	(Voltage adjustment)	0% to 300%	100
F31	(Function)	0 to 16	0
F32	Analog Output [FM2] (Mode selection)	0: Output in voltage (0 to 10 VDC); 1: Output in current (4 to 20 mA DC)	0
F34	(Voltage adjustment)	0% to 300%	100
F35	(Function)	0 to 16	0

F37	Load Selection/ Auto Torque Boost/ Auto Energy Saving Operation 1	0: Variable torque load 1: Constant torque load 2: Auto torque boost 3: Auto energy saving (Variable torque load during ACC/DEC) 4: Auto energy saving (Constant torque load during ACC/DEC) 5: Auto energy saving (Auto torque boost during ACC/DEC)	1
F38	Stop Frequency (Detection mode)	0: Detected speed 1: Commanded speed	0
F39	(Holding Time)	0.00 to 10.00 s	0.00
F40	Torque Limiter 1-1	-300% to 300%; 999 (Disable)	999
F41	Torque Limiter 1-2	-300% to 300%; 999 (Disable)	999
F42	Drive Control Selection 1	0: V/f control with slip compensation inactive 1: Dynamic torque vector control 2: V/f control with slip compensation active 5: Vector control without speed sensor 6: Vector control with speed sensor	0
F43	Current Limiter (Mode selection)	0: Disable (No current limiter works.) 1: Enable at constant speed (Disable during ACC/DEC) 2: Enable during ACC/constant speed operation	2
F44	(Level)	20% to 200% (The data is interpreted as the rated output current of the inverter for 100%.)	160
F50	Electronic Thermal Overload Protection for Braking Resistor (Discharging capability)	0 (Braking resistor built-in type), 1 to 9000 kW, OFF (Disable)	*5
F51	(Allowable average loss)	0.001 to 99.99 kW	0.001
F52	(Resistance)	0.01 to 999Ω	0.01
F80	Switching between HD and LD drive modes	0: HD (High Duty) mode, 1: LD (Low Duty) mode	0

## E codes: extension terminal functions

Code	Name	Data setting range	Default setting
E01	Terminal [X1] Function	Selecting function code data assigns the corresponding function to terminals [X1] to [X7] as listed below.	0
E02	Terminal [X2] Function	0 (1000): Select multi-frequency (0 to 1 steps) ( <b>SS1</b> )	1
E03	Terminal [X3] Function	1 (1001): Select multi-frequency (0 to 3 steps) ( <b>SS2</b> )	2
E04	Terminal [X4] Function	2 (1002): Select multi-frequency (0 to 7 steps) ( <b>SS4</b> )	3
E05	Terminal [X5] Function	3 (1003): Select multi-frequency (0 to 15 steps) ( <b>SS8</b> )	4
E06	Terminal [X6] Function	4 (1004): Select ACC/DEC time (2 steps) ( <b>RT1</b> )	5
E07	Terminal [X7] Function	5 (1005): Select ACC/DEC time (4 steps) ( <b>RT2</b> )	8
		6 (1006): Enable 3-wire operation ( <b>HLD</b> )	
		7 (1007): Coast to a stop ( <b>BX</b> )	
		8 (1008): Reset alarm ( <b>RST</b> )	
		9 (1009): Enable external alarm trip ( <b>THR</b> ) (9 = Active OFF, 1009 = Active ON)	
		10 (1010): Ready for jogging ( <b>JOG</b> )	
		11 (1011): Select frequency command 2/1 ( <b>Hz2/Hz1</b> )	
		12 (1012): Select motor 2 ( <b>M2</b> )	
		13: Enable DC braking ( <b>DCBRK</b> )	
		14 (1014): Select torque limiter level 2/1 ( <b>TL2/TL1</b> )	
		15: Switch to commercial power (50 Hz) ( <b>SW50</b> )	
		16: Switch to commercial power (60 Hz) ( <b>SW60</b> )	
		17 (1017) UP (Increase output frequency) ( <b>UP</b> )	
		18 (1018): DOWN (Decrease output frequency) ( <b>DOWN</b> )	
		19 (1019): Enable data change with keypad ( <b>WE-KP</b> )	
		20 (1020): Cancel PID control ( <b>Hz/PID</b> )	
		21 (1021): Switch normal/inverse operation ( <b>IVS</b> )	
		22 (1022): Interlock ( <b>IL</b> )	
		24 (1024): Enable communications link via RS-485 or fieldbus (option)	
		25 (1025): Universal DI ( <b>U-DI</b> )	
		26 (1026): Enable auto search for idling motor speed at starting ( <b>STM</b> )	
		30 (1030): Force to stop ( <b>STOP</b> ) ((30 = Active OFF, 1030 = Active ON)	
		32 (1032): Pre-excitation ( <b>EXITE</b> )	
		33 (1033): Reset PID integral and differential components ( <b>PID-RST</b> )	
		34 (1034): Hold PID integral component ( <b>PID-HLD</b> )	
		35 (1035): Select local (keypad) operation ( <b>LOC</b> )	
		36 (1036): Select motor 3 ( <b>M3</b> )	
		37 (1037): Select motor 4 ( <b>M4</b> )	
		39: Protect motor from dew condensation ( <b>DWP</b> )	
		40: Enable integrated sequence to switch to commercial power (50 Hz) ( <b>ISW50</b> )	
		41: Enable integrated sequence to switch to commercial power (60 Hz) ( <b>ISW60</b> )	
		47 (1047): Servo-lock command ( <b>LOCK</b> )	
		48 Pulse train input (available only on terminal [X7] (E07) ( <b>PIN</b> ))	
		49 (1049) Pulse train sign (available on terminals except [X7] (E01 to E06) ( <b>sign</b> ))	
		72 (1072): Count the run time of commercial power-driven motor 1 ( <b>CRUN-M1</b> )	
		73 (1073): Count the run time of commercial power-driven motor 2 ( <b>CRUN-M2</b> )	
		74 (1074): Count the run time of commercial power-driven motor 3 ( <b>CRUN-M3</b> )	
		75 (1075): Count the run time of commercial power-driven motor 4 ( <b>CRUN-M4</b> )	
		76 (1076): Select droop control ( <b>DROOP</b> )	
		77 (1077): Cancel PG alarm ( <b>PG-CCL</b> )	

E10	Acceleration Time 2	0.00 to 6000 s	*1
E11	Deceleration Time 2	Note: Entering 0.00 cancels the acceleration time, requiring external soft-start and -stop.	*1
E12	Acceleration Time 3		*1
E13	Deceleration Time 3		*1
E14	Acceleration Time 4		*1
E15	Deceleration Time 4		*1
E16	Torque Limiter 2-1	-300% to 300%; 999 (Disable)	999
E17	Torque Limiter 2-2	-300% to 300%; 999 (Disable)	999
E20	Terminal [Y1] Function	Selecting function code data assigns the corresponding function to terminals [Y1] to [Y5A/C] and [30A/B/C] as listed below.	0
E21	Terminal [Y2] Function	0 (1000): Inverter running ( <b>RUN</b> )	1
E22	Terminal [Y3] Function	1 (1001): Frequency (speed) arrival signal ( <b>FAR</b> )	2
E23	Terminal [Y4] Function	2 (1002): Frequency (speed) detected ( <b>FDT</b> )	7
E24	Terminal [Y5A/C] Function (Relay output)	3 (1003): Undervoltage detected (Inverter stopped) ( <b>LU</b> )	15
E27	Terminal [30A/B/C] Function (Relay output)	4 (1004): Torque polarity detected ( <b>BD</b> ) 5 (1005): Inverter output limiting ( <b>OL</b> ) 6 (1006): Auto-restarting after momentary power failure ( <b>IPF</b> ) 7 (1007): Motor overload early warning ( <b>OL</b> ) 8 (1008): Keypad operation enabled ( <b>KP</b> ) 10 (1010): Inverter ready to run ( <b>RDY</b> ) 11: Switch motor drive source between commercial power and inverter output (For MC on commercial line) ( <b>SW88</b> ) 12 Switch motor drive source between commercial power and inverter output (For secondary side) ( <b>SW52-2</b> ) 13: Switch motor drive source between commercial power and inverter output (For primary side) ( <b>SW52-1</b> ) 15 (1015): Select AX terminal function (For MC on primary side) ( <b>AX</b> ) 22 (1022): Inverter output limiting with delay ( <b>IOL2</b> ) 25 (1025): Cooling fan in operation ( <b>FAN</b> ) 26 (1026): Auto-resetting ( <b>TRY</b> ) 27 (1027): Universal DO ( <b>U-DO</b> ) 28 (1028): Heat sink overheat early warning ( <b>OH</b> ) 30 (1030): Lifetime alarm ( <b>LIFE</b> ) 31 (1031): Frequency (speed) detected 2 ( <b>FDT2</b> ) 33 (1033): Reference loss detected ( <b>REF OFF</b> ) 35 (1035): Inverter output on ( <b>RUN2</b> ) 36 (1036): Overload prevention control ( <b>OLP</b> ) 37 (1037): Current detected ( <b>ID</b> ) 38 (1038): Current detected 2 ( <b>ID2</b> ) 39 (1039): Current detected 3 ( <b>ID3</b> ) 41 (1041): Low current detected ( <b>IDL</b> ) 42 (1042): PID alarm ( <b>PID-ALM</b> ) 43 (1043): Under PID control ( <b>PID-CTL</b> ) 44 (1044): Motor stopped due to slow flowrate under PID control ( <b>PID-STP</b> ) 45 (1045): Low output torque detected ( <b>U-TL</b> ) 46 (1046): Torque detected 1 ( <b>TD1</b> ) 47 (1047): Torque detected 2 ( <b>TD2</b> ) 48 (1048): Motor 1 selected ( <b>SWM1</b> ) 49 (1049): Motor 2 selected ( <b>SWM2</b> ) 50 (1050): Motor 3 selected ( <b>SWM3</b> ) 51 (1051): Motor 4 selected ( <b>SWM4</b> ) 52 (1052): Running forward ( <b>FRUN</b> ) 53 (1053): Running reverse ( <b>RRUN</b> ) 54 (1054): In remote operation ( <b>RMT</b> ) 56 (1056): Motor overheat detected by thermistor ( <b>THM</b> ) 57 (1057): Brake signal ( <b>BRKS</b> ) 58 (1058): Frequency (speed) detected 3 ( <b>FDT3</b> ) 59 (1059): Terminal [C1] wire break ( <b>C1OFF</b> ) 70 (1070): Speed valid ( <b>DNZS</b> ) 71 (1071): Speed agreement ( <b>DSAG</b> ) 72 (1072): Frequency (speed) arrival signal 3 ( <b>FAR3</b> ) 76 (1076): PG error detected ( <b>PG-ERR</b> ) 82 (1082): Positioning completion signal ( <b>PSET</b> ) 84 (1084): Maintenance timer ( <b>MNT</b> ) 98 (1098): Light alarm ( <b>L-ALM</b> ) 99 (1099): Alarm output (for any alarm) ( <b>ALM</b> ) 101 (1101): Enable circuit failure detected ( <b>DECF</b> ) 102 (1102): Enable input OFF ( <b>EN OFF</b> ) 105 (1105): Braking transistor broken ( <b>DBAL</b> )	99
E30	Frequency Arrival (Hysteresis width)	0.0 to 10.0 Hz	2.5
E31	Frequency Detection 1 (Level)	0.0 to 500.0 Hz	50.0
E32	(Hysteresis width)	0.0 to 500.0 Hz	1.0
E34	Overload Early Warning/Current Detection (Level)	0.00 (Disable); Current value of 1% to 200% of the inverter rated current	*3
E35	(Timer)	0.01 to 600.00s	10.00
E36	Frequency Detection 2 (Level)	0.0 to 500.0 Hz	50.0
E37	Current Detection 2/ Low Current Detection (Level)	0.00 (Disable); Current value of 1% to 200% of the inverter rated current	*3
E38	(Timer)	0.01 to 600.00 s	10.00

E40	PID Display Coefficient A	-999 to 0.00 to 9990	100
E41	PID Display Coefficient B	-999 to 0.00 to 9990	0.00
E42	LED Display Filter	0.0 to 5.0 s	0.5
E43	LED Monitor (Item selection)	0 to 25	0
E44	(Display when stopped)	0: Specified value 1: Output value	0
E45	LCD Monitor (Item selection)	0: Running status, rotational direction and operation guide; 1: Bar charts for output frequency, current and calculated torque	0
E46	(Language selection)	Multi-function keypad (option) 0 to 5	1
E47	(Contrast control)	0 (Low) to 10 (High)	5
E48	LED Monitor (Speed monitor item)	0 to 7	0
E50	Coefficient for Speed Indication	0.01 to 200.00	30.00
E51	Display Coefficient for Input Watt-hour Data	0.000 (Cancel/reset), 0.001 to 9999	0.010
E52	Keypad (Menu display mode)	0: Function code data editing mode (Menus #0, #1, and #7) 1: Function code data check mode (Menu #2 and #7) 2: Full-menu mode	0
E54	Frequency Detection 3 (Level)	0.0 to 500.0 Hz	50.0
E55	Current Detection 3 (Level)	0.00 (Disable); Current value of 1% to 200% of the inverter rated current	*3
E56	(Timer)	0.01 to 600.00 s	10.00
E61	Terminal [12] Extended Function	0: None	0
E62	Terminal [C1] Extended Function	1: Auxiliary frequency command 1 2: Auxiliary frequency command 2	0
E63	Terminal [V2] Extended Function	3: PID command 1 5: PID feedback amount 6: Ratio setting 7: Analog torque limit value A 8: Analog torque limit value B 20: Analog input monitor	0
E64	Saving of Digital Reference Frequency	0: Automatic saving (when main power is turned OFF); 1: Saving by pressing FUNC/DATA key	1
E65	Reference Loss Detection (Continuous running frequency)	0: Decelerate to stop, 20% to 120%, 999: Disable	999
E78	Torque Detection 1 (Level)	0% to 300%	100
E79	(Timer)	0.01 to 600.00 s	10.00
E80	Torque Detection 2/ Low Torque Detection (Level)	0% to 300%	20
E81	(Timer)	0.01 to 600.00 s	20.00
E98	Terminal [FWD] Function	Selecting function code data assigns the corresponding function to terminals [FWD] and [REV] as listed below: Same as E01-E07 plus additionally:	98
E99	Terminal [REV] Function	98: Run forward ( <b>FWD</b> ); 99: Run reverse ( <b>REV</b> )	99

### C codes: control functions of frequency

Code	Name	Data setting range	Default setting
C01-C03	Jump Frequency 1-Jump Frequency 3	0.0 to 500.0 Hz	0.0
C04	(Hysteresis width)	0.0 to 30.0 Hz	3.0
C05-C19	Multi-frequency 1-Multi-frequency 15	0.00 to 500.00 Hz	0.00
C20	Jogging frequency	0.00 to 500.00 Hz	0.00
C30	Frequency Command 2	Same as F01	2
C31	Analog Input Adjustment for [12] (Offset)	-5.0% to 5.0%	0.0
C32	(Gain)	0.00% to 200.00%	100.0
C33	(Filter time constant)	0.00 to 5.00 s	0.05
C34	(Gain base point)	0.00% to 100.00%	100.00
C35	(Polarity)	0: Bipolar 1: Unipolar	1
C36	Analog Input Adjustment for [C1] (Offset)	-5.0% to 5.0%	0.0
C37	(Gain)	0.00% to 200.00%	100.00
C38	(Filter time constant)	0.00 to 5.00s	0.05
C39	(Gain base point)	0.00% to 100.00%	100.00
C41	Analog Input Adjustment for [V2] (Offset)	-5.0% to 5.0%	0.0
C42	(Gain)	0.00% to 200.00%	100.00
C43	(Filter time constant)	0.00 to 5.00 s	0.05
C44	(Gain base point)	0.00% to 100.00%	100.00
C45	(Polarity)	0: Bipolar 1: Unipolar	1
C50	Bias (Frequency command 1) (Bias base point)	0.00% to 100.00%	0.00
C51	Bias (PID command 1) (Bias Value)	-100.00% to 100.00%	0.00
C52	(Bias base point)	0.00% to 100.00%	0.00
C53	Selection of Normal/Inverse Operation (Frequency command 1)	0: Normal operation	0

### P codes: motor 1 parameters

Code	Name	Data setting range	Default setting
P01	Motor 1 (No. of poles)	2 to 22 poles	4
P02	(Rated capacity)	0.01 to 1000 kW (when P99 = 0, 2, 3 or 4); 0.01 to 1000 HP (when P99 = 1)	*7
P03	(Rated current)	0.00 to 2000 A	*7
P04	(Auto-tuning)	0 to 3	0
P06	(No-load current)	0.00 to 2000 A	*7

P07	(%R1)	0.00% to 50.00%	*7
P08	(%X)	0.00% to 50.00%	*7
P09	(Slip compensation gain for driving)	0.0% to 200.0%	100.0
P10	(Slip compensation response time)	0.01 to 10.00 s	0.12
P11	(Slip compensation gain for braking)	0.0% to 200.0%	100.0
P12	(Rated slip frequency)	0.00 to 15.00 Hz	*7
P13	(Iron loss factor 1)	0.00% to 20.00%	*7
P14	(Iron loss factor 2)	0.00% to 20.00%	0.00
P15	(Iron loss factor 3)	0.00% to 20.00%	0.00
P16	(Magnetic saturation factor 1)	0.0% to 300.0%	*7
P17	(Magnetic saturation factor 2)	0.0% to 300.0%	*7
P18	(Magnetic saturation factor 3)	0.0% to 300.0%	*7
P19	(Magnetic saturation factor 4)	0.0% to 300.0%	*7
P20	(Magnetic saturation factor 5)	0.0% to 300.0%	*7
P21	(Magnetic saturation extension factor "a")	0.0% to 300.0%	*7
P22	(Magnetic saturation extension factor "b")	0.0% to 300.0%	*7
P23	(Magnetic saturation extension factor "c")	0.0% to 300.0%	*7
P53	(%X correction factor 1)	0% to 300%	100
P54	(%X correction factor 2)	0% to 300%	100
P55	(Torque current under vector control)	0.00 to 2000 A	*7
P56	(Induced voltage factor under vector control)	50% to 100%	85
P99	Motor 1 Selection	0 to 4	0

## H codes: high performance functions

Code	Name	Data setting range	Default setting
H03	Data Initialization	0 to 5	0
H04	Auto-reset (Times)	0: Disable; 1 to 10	0
H05	(Reset interval)	0.5 to 20.0 s	5.0
H06	Cooling Fan ON/OFF Control	0: Disable (Always in operation), 1: Enable (ON/OFF controllable)	0
H07	Acceleration/Deceleration Pattern	0: Linear 1: S-curve (Weak) 2: S-curve (Arbitrary, according to H57 to H60 data) 3: Curvilinear	0
H08	Rotational Direction Limitation	0: Disable; 1: Enable (Reverse rotation inhibited); 2: Enable (Forward rotation inhibited)	0
H09	Starting Mode (Auto search)	0: Disable 1: Enable (At restart after momentary power failure) 2: Enable (At restart after momentary power failure and at normal start)	0
H11	Deceleration Mode	0: Normal deceleration 1: Coast-to-stop	0
H12	Instantaneous Overcurrent Limiting (Mode selection)	0: Disable; 1: Enable	1
H13	Restart Mode after Momentary Power Failure (Restart time)	0.1 to 10.0 s	*2
H14	(Frequency fall rate)	0.00: Deceleration time selected by F08, 0.01 to 100.00 Hz/s, 999: Follow the current limit command	999
H15	(Continuous running level)	400 to 600 V for 400 V class series	470
H16	(Allowable momentary power failure time)	0.0 to 30.0 s; 999: Automatically determined by inverter	999
H26	Thermistor (for motor)	0: Disable (Mode selection) 1: PTC (The inverter immediately trips with <i>Oh4</i> displayed.) 2: PTC (The inverter issues output signal <i>THM</i> and continues to run.) 3: NTC (When connected)	0
H27	(Level)	0.00 to 5.00 V	0.35
H28	Drop Control	-60.0 to 0.0 Hz	0.0
H30	Communications Link Function (Mode selection)	0 to 8	0
H42	Capacitance of DC Link Bus Capacitor	Indication for replacement of DC link bus capacitor: 0000 to FFFF (hex.)	-
H43	Cumulative Run Time of Cooling Fan	Indication for replacement of cooling fan (in units of 10 hours)	-
H44	Startup Counter for Motor 1	Indication of cumulative startup count: 0000 to FFFF (hex.)	-
H45	Mock Alarm	0: Disable; 1: Enable (Once a mock alarm occurs, the data automatically returns to 0)	0
H46	Starting Mode (Auto search delay time 2)	0.1 to 10.0 s	*7
H47	Initial Capacitance of DC Link Bus Capacitor	Indication for replacement of DC link bus capacitor: 0000 to FFFF (hex.)	-
H48	Cumulative Run Time of Capacitors on Printed Circuit Boards	Indication for replacement of capacitors (The cumulative run time can be modified or reset in units of 10 hours).	-
H49	Starting Mode (Auto search delay time 1)	0.0 to 10.0 s	0.0
H50	Non-linear V/f Pattern 1 (Frequency)	0.0: Cancel, 0.1 to 500.0 Hz	*8
H51	(Voltage)	0 to 500: Output an AVR-controlled voltage	*8
H52	Non-linear V/f Pattern 2 (Frequency)	0.0: Cancel, 0.1 to 500.0 Hz	0.0
H53	(Voltage)	0 to 500: Output an AVR-controlled voltage	0
H54	Acceleration Time (Jogging)	0.00 to 6000 s	*1
H55	Deceleration Time (Jogging)	0.00 to 6000 s	*1
H56	Deceleration Time for Forced Stop	0.00 to 6000 s	*1
H57	1st S-curve acceleration range (Leading edge)	0% to 100%	10
H58	2nd S-curve acceleration range (Trailing edge)	0% to 100%	10
H59	1st S-curve deceleration range (Leading edge)	0% to 100%	10
H60	2nd S-curve deceleration range (Trailing edge)	0% to 100%	10
H61	UP/DOWN Control (Initial frequency setting)	0: 0.00 Hz; 1: Last UP/DOWN command value on releasing the run command	1

H63	Low Limiter (Mode selection)	0: Limit by F16 (Frequency limiter: Low) and continue to run 1: If the output frequency lowers below the one limited by F16 (Frequency limiter: Low), decelerate to stop the motor.	0
H64	Low Limiter	0.0: Depends on F16 (Frequency limiter, Low); 0.1 to 60.0 Hz	1.6
H65	Non-linear V/f Pattern 3 (Frequency)	0.0: Cancel, 0.1 to 500.0 Hz	0.0
H66	(Voltage)	0 to 500: Output an AVR-controlled voltage	0
H67	Auto Energy Saving Operation (Mode selection)	0: Enable during running at constant speed; 1: Enable in all modes	0
H68	Slip Compensation 1 (Operating conditions)	0: Enable during ACC/DEC and at base frequency or above 1: Disable during ACC/DEC and enable at base frequency or above 2: Enable during ACC/DEC and disable at base frequency or above 3: Disable during ACC/DEC and at base frequency or above	0
H69	Automatic Deceleration (Mode selection)	0 to 5	0
H70	Overload Prevention Control	0.00: Follow the deceleration time selected; 0.01 to 100.0 Hz/s; 999: Cancel	999
H71	Deceleration Characteristics	0: Disable 1: Enable	0
H72	Main Power Down Detection (Mode selection)	0: Disable 1: Enable	1
H73	Torque Limiter (Operating conditions)	0 to 2	0
H76	(Frequency increment limit for braking)	0.0 to 500.0 Hz	5.0
H77	Service Life of DC Link Bus Capacitor (Remaining time)	0 to 8760 (in units of 10 hours)	-
H78	Maintenance Interval (M1)	0: Disable; 1 to 9999 (in units of 10 hours)	8760
H79	Preset Startup Count for Maintenance (M1)	0000: Disable; 0001 to FFFF (hex.)	0
H80	Output Current Fluctuation Damping Gain for Motor 1	0.00 to 0.40	0.20
H81	Light Alarm Selection 1	0000 to FFFF (hex.)	0
H82	Light Alarm Selection 2	0000 to FFFF (hex.)	0
H84	Pre-excitation (Initial level)	100% to 400%	100
H85	(Time)	0.00: Disable; 0.01 to 30.00 s	0.00
H91	PID Feedback Wire Break Detection	0.0: Disable alarm detection; 0.1 to 60.0 s	0.0
H92	Continuity of Running (P)	0.000 to 10.000 times; 999	999
H93	(I)	0.010 to 10.000 s; 999	999
H94	Cumulative Motor Run Time 1	0 to 9999 (The cumulative run time can be modified or reset in units of 10 hours.)	-
H95	DC Braking (Braking response mode)	0: Slow; 1: Quick	1
H96	STOP Key Priority/Start Check Function	0 to 3	0
H97	Clear Alarm Data	0: Disable; 1: Enable (Setting "1" clears alarm data and then returns to "0.")	0
H98	Protection/Maintenance Function (Mode selection)	0 to 255: Display data in decimal format	83

#### A, b, r codes: Motor 2, 3, 4 parameters

Code	Name	Data setting range	Default setting
_01	Maximum Frequency 2, 3, 4	25.0 to 500.0 Hz	50
_02	Base Frequency 2, 3, 4	25.0 to 500.0 Hz	50.0
_03	Rated Voltage at Base Frequency 2, 3, 4	0: Output a voltage in proportion to input voltage 160 to 500: Output an AVR-controlled voltage	400
_04	Maximum Output Voltage 2, 3, 4	160 to 500: Output an AVR-controlled voltage	400
_05	Torque Boost 2, 3, 4	0.0% to 20.0% (percentage with respect to b03)	*2
_06	Electronic Thermal Overload Protect. for Motor 2, 3, 4 (Select motor characteristics)	1: For a general-purpose motor with shaft-driven cooling fan 2: For an inverter-driven motor, non-ventilated motor, or motor with separately powered cooling fan	1
_07	(Overload detection level)	0.00: Disable 1% to 135% of the rated current (allowable continuous drive current) of the motor	*3
_08	(Thermal time constant)	0.5 to 75.0 min	*4
_09	DC Braking 2, 3, 4 (Braking starting frequency)	0.0 to 60.0 Hz	0.0
_10	(Braking level)	0% to 100% (HD mode), 0% to 80% (LD mode)	0
_11	(Braking time)	0.00: Disable; 0.01 to 30.00 s	0.00
_12	Starting Frequency 2, 3, 4	0.0 to 60.0 Hz	0.5
_13	Load Selection/Auto Torque Boost/Auto Energy Saving Operation 2, 3, 4	Same as F37	1
_14	Drive Control Selection 2, 3, 4	Same as F42	0
_15	Motor 2, 3, 4 (No. of poles)	2 to 22 poles	4
_16	(Rated capacity)	0.01 to 1000 kW (when b39 = 0, 2, 3 or 4); 0.01 to 1000 HP (when b39 = 1)	*6
_17	(Rated current)	0.00 to 2000 A	*6
_18	(Auto-tuning)	Same as P04	0
_20	(No-load current)	0.00 to 2000 A	*6
_21	(%R1)	0.00% to 50.00%	*6
_22	(%X)	0.00% to 50.00%	*6
_23	(Slip compensation gain for driving)	0.0% to 200.0%	100.0
_24	(Slip compensation response time)	0.01 to 10.00 s	0.12
_25	(Slip compensation gain for braking)	0.0% to 200.0%	100.0
_26	(Rated slip frequency)	0.00 to 15.00 Hz	*6
_27	(Iron loss factor 1)	0.00% to 20.00%	*6
_28	(Iron loss factor 2)	0.00% to 20.00%	0.00
_29	(Iron loss factor 3)	0.00% to 20.00%	0.00
_30	(Magnetic saturation factor 1)	0.0% to 300.0%	*6
_31	(Magnetic saturation factor 2)	0.0% to 300.0%	*6
_32	(Magnetic saturation factor 3)	0.0% to 300.0%	*6
_33	(Magnetic saturation factor 4)	0.0% to 300.0%	*6
_34	(Magnetic saturation factor 5)	0.0% to 300.0%	*6

_35	(Magnetic saturation extension factor "a")	0.0% to 300.0%	*6
_36	(Magnetic saturation extension factor "b")	0.0% to 300.0%	*6
_37	(Magnetic saturation extension factor "c")	0.0% to 300.0%	*6
_39	Motor 2, 3, 4 Selection	0 to 4	0
_40	Slip Compensation 2, 3, 4 (Operating conditions)	Same as H68	0
_41	Output Current Fluctuation Damping Gain for Motor 2, 3, 4	0.00 to 0.40	0.20
_42	Motor/Parameter Switching 2, 3, 4 (Mode selection)	0: Motor (Switch to motor 2, 3, 4); 1: Parameter (Switch to particular b codes)	0
_43	Speed Control 2, 3, 4 (Speed command filter)	0.000 to 5.000 s	0.020
_44	(Speed detection filter)	0.000 to 0.100 s	0.005
_45	P (Gain)	0.1 to 200.0 times	10.0
_46	I (Integral time)	0.001 to 1.000 s	0.100
_48	(Output filter)	0.000 to 0.100 s	0.020
_51	Cumulative Motor Run Time 2, 3, 4	0 to 9999 (The cumulative run time can be modified or reset in units of 10 hours.)	-
_52	Startup Counter for Motor 2, 3, 4	Indication of cumulative startup count 0000 to FFFF (hex.)	-
_53	Motor 2, 3, 4 (%X correction factor 1)	0% to 300%	100
_54	(%X correction factor 2)	0% to 300%	100
_55	(Torque current under vector control)	0.00 to 2000 A	*6
_56	(Induced voltage factor under vector control)	50 to 100	85

## J codes: application functions 1

Code	Name	Data setting range	Default setting
J01	PID Control (Mode selection)	0 to 3	0
J02	(Remote command SV)	0 to 4	0
J03	P (Gain)	0.000 to 30.000 times	0.100
J04	I (Integral time)	0.0 to 3600.0 s	0.0
J05	D (Differential time)	0.00 to 600.00 s	0.00
J06	(Feedback filter)	0.0 to 900.0 s	0.5
J08	(Pressurization starting frequency)	0.0 to 500.0 Hz	0.0
J09	(Pressurizing time)	0 to 60 s	0
J10	(Anti reset windup)	0% to 200%	200
J11	(Select alarm output)	0 to 7	0
J12	(Upper level alarm (AH))	-100% to 100%	100
J13	(Lower level alarm (AL))	-100% to 100%	0
J15	(Stop frequency for slow flowrate)	0.0: Disable; 1.0 to 500.0 Hz	0.0
J16	(Slow flowrate level stop latency)	0 to 60 s	30
J17	(Starting frequency)	0.0 to 500.0 Hz	0.0
J18	(Upper limit of PID process output)	-150% to 150%; 999: Depends on setting of F15	999
J19	(Lower limit of PID process output)	-150% to 150%; 999: Depends on setting of F16	999
J21	Dew Condensation Prevention (Duty)	1% to 50%	1
J22	Commercial Power Switching Sequence	0: Keep inverter operation (Stop due to alarm); 1: Automatically switch to commercial-power operation	0
J56	PID Control (Speed command filter)	0.00 to 5.00 s	0.10
J57	(Dancer reference position)	-100% to 0% to 100%	0
J58	(Detection width of dancer position deviation)	0: Disable switching PID constant; 1% to 100% (Manually set value)	0
J59	P (Gain) 2	0.000 to 30.000 times	0.100
J60	I (Integral time) 2	0.0 to 3600.0 s	0.0
J61	D (Differential time) 3	0.00 to 600.00 s	0.00
J62	(PID control block selection)	0 to 3	0
J68	Brake Signal (Brake-OFF current)	0% to 300%	100
J69	(Brake-OFF frequency/speed)	0.0 to 25.0 Hz	1.0
J70	(Brake-OFF timer)	0.0 to 5.0 s	1.0
J71	(Brake-ON frequency/speed)	0.0 to 25.0 Hz	1.0
J72	(Brake-ON timer)	0.0 to 5.0 s	1.0
J95	(Brake-OFF torque)	0% to 300%	100
J96	(Speed selection)	0: Detected speed 1; Commanded speed	0
J97	Servo-lock (Gain)	0.00 to 10.00	0.10
J98	(Completion timer)	0.000 to 1.000 s	0.100
J99	(Completion width)	0 to 9999	10

## d codes: application functions 2

Code	Name	Data setting range	Default setting
d01	Speed control 1 (Speed command filter)	0.000 to 5.000 s	0.020
d02	(Speed detection filter)	0.000 to 0.100 s	0.005
d03	P (Gain)	0.1 to 200.0 times	10.0
d04	I (Integral time)	0.001 to 1.000 s	0.100
d06	(Output filter)	0.000 to 0.100 s	0.002
d09	Speed control (Jogging) (Speed command filter)	0.000 to 5.000 s	0.020
d10	(Speed detection filter)	0.000 to 0.100 s	0.005
d11	P (Gain)	0.1 to 200.0 times	10.0
d12	I (Integral time)	0.001 to 1.000 s	0.100
d13	(Output filter)	0.000 to 0.100 s	0.002

d14	Feedback Input (Pulse input property)	0: Pulse train sign/Pulse train input 1: Forward rotation pulse/Reverse rotation pulse 2: A/B phase with 90 degree phase shift	2
d15	(Encoder pulse resolution)	0014H to EA60H (20 to 60000 pulses)	400H (1024)
d16	(Pulse count factor 1)	1 to 9999	1
d17	(Pulse count factor 2)	1 to 9999	1
d21	Speed Agreement/PG Error (Hysteresis width)	0.0% to 50.0%	10.0
d22	(Detection timer)	0.00 to 10.00 s	0.50
d23	PG Error Processing	0: Continue to run; 1: Stop running with alarm 1; 2: Stop running with alarm 2	2
d24	Zero Speed Control	0: Not permit at startup; 1: Permit at startup	0
d25	ASR Switching Time	0.000 to 1.000 s	0.000
d32	Torque control (Speed limit 1)	0 to 110 %	100
d33	(Speed limit 2)	0 to 110 %	100
d59	Command (Pulse Rate Input) (Pulse input property)	0: Pulse train sign/Pulse train input 1: Forward rotation pulse/Reverse rotation pulse 2: A/B phase with 90 degree phase shift	0
d61	(Filter time constant)	0.000 to 5.000 s	0.005
d62	(Pulse count factor 1)	1 to 9999	1
d63	(Pulse count factor 2)	1 to 9999	1
d67	Starting Mode (Auto search)	0: Disable 1: Enable (At restart after momentary power failure) 2: Enable (At restart after momentary power failure and at normal start)	2

### y codes: link functions

Code	Name	Data setting range	Default setting
y01	RS-485 Communication 1 (Station address)	1 to 255	1
y02	(Communications error processing)	0: Immediately trip with alarm <i>erp</i> 1: Trip with alarm <i>erp</i> after running for the period specified by timer y03 2: Retry during the period specified by timer y03. If the retry fails, trip with alarm <i>erp</i> . If it succeeds, continue to run. 3: Continue to run	0
y03	(Timer)	0.0 to 60.0 s	2.0
y04	(Baud rate)	0: 2400 bps; 1: 4800 bps; 2: 9600 bps; 3: 19200 bps; 4: 38400 bps	3
y05	(Data length)	0: 8 bits; 1: 7 bits	0
y06	(Parity check)	0: None (2 stop bits) 1: Even parity (1 stop bit) 2: Odd parity (1 stop bit) 3: None (1 stop bit)	0
y07	(Stop bits)	0: 2 bits; 1: 1 bit	0
y08	(No-response error detection time)	0: No detection; 1 to 60 s	0
y09	(Response interval)	0.00 to 1.00 s	0.01
y10	(Protocol selection)	0: Modbus RTU protocol 1: FRENIC Loader protocol (SX protocol) 2: Fuji general-purpose inverter protocol	1
y11	RS-485 Communication (Station address)	1 to 255	1
y12	(Communications error processing)	Same as y02 but y13 applies instead of y03	0
y13	(Timer)	0.0 to 60.0 s	2.0
y14	RS-485 Communication 2 (Baud rate)	Same as y04	3
y15	(Data length)	0: 8 bits; 1: 7 bits	0
y16	(Parity check)	Same as y06	0
y17	(Stop bits)	0: 2 bits; 1: 1 bit	0
y18	(No-response error detection time)	0: No detection; 1 to 60 s	0
y19	(Response interval)	0.00 to 1.00 s	0.01
y20	(Protocol selection)	0: Modbus RTU protocol; 2: Fuji general-purpose inverter protocol	0
y97	Communication Data Storage Selection	0 to 2	0
y98	Bus Link Function (Mode selection)	0 to 3	0
y99	Loader Link Function (Mode selection)	0 to 3	0

- \*1 6.00 s for inverters with a capacity of 22 kW or below; 20.00 s for those with 30 kW or above.
- \*2 The factory default differs depending upon the inverter's capacity.
- \*3 The motor rated current is automatically set, depending on the setting of function P02.
- \*4 5.0 min for inverters with a capacity of 22 kW or below; 10.0 min for those with 30 kW or above.
- \*5 0 for inverters with a capacity of 7.5 kW or below; OFF for those with 11 kW or above.
- \*6 The motor constant is automatically set, depending upon the inverter's capacity and shipping destination.
- \*7 The factory default differs depending upon the inverter's capacity.

## Chapter 7 TROUBLESHOOTING

### WARNING

If any of the protective functions has been activated, first remove the cause. Then, after checking that the all run commands are set to OFF, release the alarm. If the alarm is released while any run commands are set to ON, the inverter may supply the power to the motor, running the motor.

**Injury may occur.**

- Even though the inverter has interrupted power to the motor, if the voltage is applied to the main circuit input terminals L1/R, L2/S and L3/T, voltage may be output to inverter output terminals U, V, and W.
- Turn OFF the power and wait at least five minutes for inverters with a capacity of 22 kW or below, or at least ten minutes for inverters with a capacity of 30 kW or above. Make sure that the LED monitor and charging lamp are turned OFF. Further, make sure, using a multimeter or a similar instrument, that the DC link bus voltage between the terminals P (+) and N (-) has dropped to the safe level (+25 VDC or below).

**Electric shock may occur.**

### 7.1 Description of major protective functions

Alarm code	Alarm name	Alarm description
Oc1	Overcurrent protection during acceleration	Excessive output current due to: <ul style="list-style-type: none"> <li>- Excessive motor load.</li> <li>- Acceleration (deceleration) too fast.</li> <li>- Short circuit in the output circuit.</li> <li>- Ground fault (this protection is effective only during start up).</li> </ul>
Oc2	Overcurrent protection during deceleration	
Oc3	Overcurrent protection at constant speed	
Ou1	Overvoltage protection during acceleration	Voltage in the DC link too high (400 V for 200 V class inverters; 800 V for 400 V class inverters) due to: <ul style="list-style-type: none"> <li>- Deceleration too fast.</li> <li>- The motor is regenerating energy and there is no braking resistor connected to the inverter.</li> </ul>
Ou2	Overvoltage protection during deceleration	
Ou3	Overvoltage protection at constant speed	This protection may not protect the case where the supply voltage is excessive
Lu	Undervoltage protection	Voltage in the DC link too low (200 V for 200 V class inverters; 400 V for 400 V class inverters). In the case F14=4 or 5, then this alarm does not go off when the voltage in the DC link is low.
Lin	Input phase loss protection	Input phase loss.  If the inverter load is low or a DC reactor is installed the event of an input phase loss may be not detected.
Opl	Output phase lost protection	An output phase of the inverter is in open circuit.
Oh1	Overheat protection	Excessive heat sink temperature due to: <ul style="list-style-type: none"> <li>- Inverter fan is not working.</li> <li>- The inverter is overloaded.</li> </ul>
Dbh	External braking resistor overheat	Overheating of the external braking resistor
Olu	Overload protection	IGBT internal temperature calculated from the output current and from the temperature inside the inverter is over the preset value.
Oh2	External alarm input	A digital input is programmed with the function THR (9) and has been deactivated.
OI1	Electronic thermal overload motor 1	The inverter is protecting the motor in accordance with the electronic thermal overload protection setting: <ul style="list-style-type: none"> <li>- F10 (A06, b06, r06) =1 is for general purpose motors.</li> <li>- F10 (A06, b06, r06) =2 is for inverter motors.</li> <li>- F11 (A07, b07, r07) defines the operation level (current level).</li> <li>- F12 (A08, b08, r08) defines the thermal time constant.</li> </ul> F functions are for motor 1, A functions are for motor 2, b functions are for motor 3 and r functions are for motor 4.
OI2	Electronic thermal overload motor 2	
Oh4	PTC thermistor	The thermistor input has stopped the inverter to protect the motor. The thermistor has to be connected between terminals [C1] and [11]. Also the slide switch has to be set to the correct position and functions H26 (enable) and H27 (level) have to be set.
Er1	Memory error detection	Memory error has been detected during power up.
Er2	Keypad communications error detection	The inverter has detected a communications error with the keypad (standard keypad or multifunction keypad).
Er3	CPU error detection	Inverter has detected a CPU error or LSI error caused by noise or some other factors.
Er4	Option communications error detection	Inverter has detected a communications error with the option card.
Er5	Option error detection	The option card has detected an error.

## Chapter 8 SPECIFICATIONS

### 8.1 Standard Model (EMC Filter Built-in Type)

#### 8.1.1 Three-phase 400 V class series (HD- and LD-mode inverters)

Item	Specifications																		
Type (FRN__ _G1E-4□)	0.4	0.75	1.5	2.2	3.7 (4.0) <sup>+1</sup>	5.5	7.5	11	15	18.5	22	30	37	45	55	75			
Nominal applied motor (kW) *2	HD	0.4	0.75	1.5	2.2	3.7 (4.0) <sup>+1</sup>	5.5	7.5	11	15	18.5	22	30	37	45	55	75		
	LD	–	–	–	–	–	7.5	11	15	18.5	22	30	37	45	55	75	90		
Rated capacity (kVA) *3	HD	1.1	1.9	2.8	4.1	6.8	10	14	18	24	29	34	45	57	69	85	114		
	LD	–	–	–	–	–	12	17	22	28	33	45	57	69	85	114	134		
Output ratings	Rated voltage (V) *4	Three-phase 380 to 480 V (with AVR function)																	
	Rated current (A)	HD	1.5	2.5	4.0	5.5	9.0	13.5	18.5	24.5	32	39	45	60	75	91	112	150	
		LD	–	–	–	–	–	16.5	23	30.5	37	45	60	75	91	112	150	176	
	Overload capability	HD	150%-1 min, 200%-3.0 s																
		LD	– 120%-1 min																
Input power	Voltage, frequency	380 to 480 V, 50/60 Hz															+5		
	Allowable voltage/frequency	Voltage: +10 to -15% (Interphase voltage unbalance: 2% or less) *6, Frequency: +5 to -5%																	
Required capacity (with DCR) (kVA) *7	HD	0.6	1.2	2.1	3.2	5.2	7.4	10	15	20	25	30	40	48	58	71	96		
	LD	–	–	–	–	–	10	15	20	25	30	40	48	58	71	96	114		
Braking	Torque (%) *8	HD	150%			100%			20%			10 to 15%							
		LD	–			70%			15%			7 to 12%							
	Braking transistor	Built-in																	
	Built-in braking resistor Braking time (s)	HD	5 s																
		LD	–			3.7 s			3.4 s			–							
Duty cycle (%ED)	HD	5	3	5	3	2	3	2	–										
	LD	–			2.2			1.4			–								
EMC filter	Compliant with EMC Directives, Emission and Immunity: Category C3 (2nd Env.) (EN61800-3:2004)																		
DC reactor (DCR)	Option *9																		
Applicable safety standards	UL508C, C22.2No.14, EN50178:1997																		
Enclosure (IEC60529)	IP20, UL open type											IP00, UL open type							
Cooling method	Natural cooling							Fan cooling											
Weight / Mass (kg)	1.8	2.1	2.7	2.9	3.2	6.8	6.9	6.2	10.5	10.5	11.2	26	27	32	33	42			

\*1 4.0 kW for the EU. The inverter type is FRN4.0G1E-4E.

\*2 Fuji 4-pole standard motor

\*3 Rated capacity is calculated assuming the rated output voltage as 440 V for 400 V class series.

\*4 Output voltage cannot exceed the power supply voltage.

\*5 380 to 440 V, 50 Hz; 380 to 480 V, 60 Hz

\*6 
$$\text{Voltage unbalance (\%)} = \frac{\text{Max. voltage (V)} - \text{Min. voltage (V)}}{\text{Three-phase average voltage (V)}} \times 67 \text{ (IEC 61800-3)}$$

If this value is 2 to 3%, use an optional AC reactor (ACR).

\*7 Required when a DC reactor (DCR) is used.

\*8 Average braking torque for the motor running alone. (It varies with the efficiency of the motor.)

\*9 A DC reactor (DCR) is an option. However, inverters with a capacity of 55 kW in LD mode and inverters with 75 kW or above require a DCR to be connected. Be sure to connect it to those inverters.

**Note:** A box (□) in the above table replaces A or E depending on the shipping destination.



## Chapter 9 OPTIONS

Option name		Function and application
Main options	DC reactor (DCRE)	The DC reactor is used to reduce harmonic components on the input current (mains supply) of the inverter. <b>Note:</b> DO NOT FORGET to remove the DC link bar between P1 and P(+) before installing this option.
	Output filter	Install an output filter between the inverter and the motor to (mainly because motor cable is long): 1) Reduce the voltage peaks at the motor terminals (therefore protecting the motor insulation) 2) Reducing the high frequency currents due to the cable stray capacitance (therefore protecting the inverter) 3) Reduce the leakage current on the output of the inverter 4) Reduce harmonics and losses at the output of the inverter 5) Reduce emission and induction noise generated from the motor power cable. 6) Reduce acoustic noise in the motor <b>Note:</b> When using an output filter, set the switching frequency of the inverter (function code F26) within the allowable range specified by the filter manufacturer, otherwise the filter will overheat.
	Ferrite ring reactors (ACL)	The ferrite ring reactors are used to reduce radiated emissions from the inverter.
	EMC input filter	The EMC input filter is used to make the inverter conform to a higher level of EMC compliance.
	AC reactor (ACRE)	Use an optional AC reactor if the input voltage unbalance rate is 2% to 3%. Use also an AC reactor when a very stable DC link voltage is needed, for example in shared DC link operation. $\text{Inter - phase voltage unbalance} = \frac{\text{Max. voltage (V)} - \text{Min. voltage (V)}}{3 \text{ phase average voltage (V)}} \times 67$ (see EN 61800-3:2004)
Operation and communication options	Multi-function keypad (TP-G1-J1) 	Allows the user to monitor the status of the inverter (voltage, output current, input power, ...), as well as to set parameters values in a conversational mode (6 languages available). It is able to store three complete inverter function sets. It includes a Liquid Crystal Display.
	Extension cable for keypad (CB-...S)	The extension cable allows to connect the keypad to the inverter remotely. Three lengths are available: 5 m (CB-5S), 3 m (CB-3S) and 1 m (CB-1S).
	PG option card (OPC-G1-PG)	This card allows to connect a pulse train signal or a signal from a Pulse Generator. This signal may be used to generate a speed reference or to close the speed and/or position loop. The voltage level of the pulse signal that can be connected to this card is 12-15 V HTL.
	PG2 option card (OPC-G1-PG2)	This card allows to connect a pulse train signal or a signal from a Pulse Generator. This signal may be used to generate a speed reference or to close the speed and/or position loop. The voltage level of the signal that can be connected to this card is 5 V TTL (Line Driver signal).
	ProfiBus-DP interface card	This card is used to communicate the inverter to a ProfiBus DP master unit.
	DeviceNet interface card	This card is used to communicate the inverter to a DeviceNet master unit.
	CANopen interface card	This card is used to communicate the inverter to a CANopen master unit.
	CC Link interface card	This card is used to communicate the inverter to a device with CC Link interface.
	SX Bus interface card	This card is used to communicate the inverter to a SX Bus master unit.
	Digital input expansion card	This card is used to expand the number of digital inputs (16 additional inputs) of the inverter.
	Digital output expansion card	This card is used to expand the number of transistor digital outputs (8 additional outputs) of the inverter.
	Relay output expansion card	This card is used to expand the number of relay digital outputs (2 additional outputs) of the inverter.
	Analog input-output expansion card	This card is used to expand the number of analog inputs (2) and analog outputs (2) of the inverter.
	Loader software	PC software, Windows GUI (Graphics user interface) based that allows to set inverter function values more easily. Also allows to upload/download all the function values to/from a file.

## CONTACT INFORMATION

### Headquarters Europe

#### Fuji Electric FA Europe GmbH

Goethering 58  
63067 Offenbach/Main  
Germany  
Tel.: +49 (0)69 669029 0  
Fax: +49 (0)69 669029 58  
info\_inverter@fujielectric.de  
www.fujielectric.de

#### Germany

Fuji Electric FA Europe GmbH  
Sales area South  
Drosselweg 3  
72666 Neckartailfingen  
Tel.: +49 (0)7127 9228 00  
Fax: +49 (0)7127 9228 01  
hgneiting@fujielectric.de

#### Switzerland

Fuji Electric FA Schweiz  
ParkAltenrhein  
9423 Altenrhein  
Tel.: +41 71 85829 49  
Fax.: +41 71 85829 40  
info@fujielectric.ch  
www.fujielectric.ch

### Headquarters Japan:

#### Fuji Electric FA Components & Systems Co. Ltd

Mitsui Sumitomo Bank Ningyo-cho Bldg. 5-7  
Nihonbashi Odemma-cho  
Chuo-ku  
Tokio 103-0011  
Japan  
Tel.: +81 3 5847 8011  
Fax: +81 3 5847 8172  
www.fujielectric.co.jp/fcs

#### Fuji Electric FA Europe GmbH

Sales area North  
Friedrich-Ebert-Str. 19  
35325 Mücke  
Tel.: +49 (0)6400 9518 14  
Fax: +49 (0)6400 9518 22  
mrost@fujielectric.de

#### Spain

Fuji Electric FA España  
Ronda Can Fatjó 5, Edifici D, Local B  
Parc Tecnològic del Vallès  
08290 Cerdanyola (Barcelona)  
Tel.: +34 93 5824333/5  
Fax: +34 93 5824344  
droy@fujielectric.de