

**Features:**

- ☑ degree of protection IP55
- ☑ V/F characteristics control
- ☑ Open Loop Vector Control (200% start torque)
- ☑ Closed Loop Encoder control (plug-In)
- ☑ Open and Closed Loop control for synchronous motors
- ☑ PTC-input
- ☑ max. rotating field frequency 500Hz
- ☑ safety control according to IEC 61508 SIL2
- ☑ integrated braking chopper
- ☑ built-in DC reactor as standard
- ☑ integrated mains filter
- ☑ integrated Modbus RTU module and CANbus



AC Drive  
VD i 1100 ... 16000/3Pro/IP55



**Function:**

- ☑ control and setpoint entry via terminals, operating units and bus systems
- ☑ PWM-clock frequency 4 - 32kHz
- ☑ sensorless speed and torque control
- ☑ potential-free control and signalling contacts
- ☑ 150% overload for 60s
- ☑ integrated PI controller
- ☑ detailed trouble check via parameter P0-13
- ☑ integrated PLC

**Typical Application:**

- |                                |                         |
|--------------------------------|-------------------------|
| ☑ lifts and hoisting units     | ☑ centrifuges           |
| ☑ pumps                        | ☑ wood working machines |
| ☑ grinding machines            | ☑ conveying systems     |
| ☑ ventilators                  | ☑ printing machinery    |
| ☑ textile machines             | ☑ packaging machines    |
| ☑ drives requiring high torque |                         |

**Options:** (Please see accessories, Page 4.27)

- ☑ remote control module
- ☑ input and output module
- ☑ RJ45-cable and cable splitter
- ☑ Encoder-module
- ☑ communication- and bus-plug-ins
- ☑ Bluetooth-memory stick
- ☑ braking resistors
- ☑ software for parameterization and operating
- ☑ license key for PLC

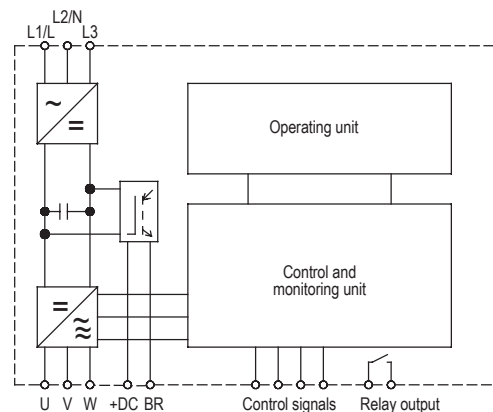

Technical Data	VD i ... /3Pro/IP55												
	1100	1500	1850	2200	3000	3700	4500	5500	7500	9000	11000	13200	16000
Motor shaft power / kW	11	15	18,5	22	30	37	45	55	75	90	110	132	160
Mains voltage according to DIN EN 50160 (IEC 38)	Three-phase 380-480V ± 10%, 48-62Hz												
Output current / A	25	30	39	46	61	72	90	110	150	180	202	240	300
Peak current for 1min. / A	38	45	59	69	91	108	135	165	225	270	303	360	450
Control functions													
Frequency setting range	0 – 500Hz												
Torque boost	Boost (U/f) adjustable via parameter setting; Open Loop vector control												
Ramp-up and ramp-down time	0 ... 3000s												
Frequency setpoint	potentiometer >= 1kΩ, 0-10V, 4-20mA, keypad, fixes frequencies, motor potentiometer, modbus RTU, CANbus												
Ambient / Storage temperature	-10 ... 50°C, -40 ... 60°C												
Weight / kg	11,5	11,5	11,5	11,5	22,5	22,5	50	50	50	50	80	80	80
Order number 21101.	40011	40015	40018	40022	40030	40037	40045	40055	40075	40090	40110	40132	40160

## Dimensions:

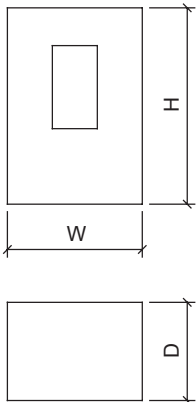

	w [mm]	H [mm]	d [mm]
VD i 1100/3Pro/IP55	173	440	230
VD i 1500/3Pro/IP55	173	440	230
VD i 1850/3Pro/IP55	173	440	230
VD i 2200/3Pro/IP55	173	440	230
VD i 3000/3Pro/IP55	235	540	270
VD i 3700/3Pro/IP55	235	540	270
VD i 4500/3Pro/IP55	330	865	340
VD i 5500/3Pro/IP55	330	865	340
VD i 7500/3Pro/IP55	330	865	340
VD i 9000/3Pro/IP55	330	865	340
VD i 11000/3Pro/IP55	330	1280	370
VD i 13200/3Pro/IP55	330	1280	370
VD i 16000/3Pro/IP55	330	1280	370

## Connection Diagram:

