

Combined Motor Start and Braking Devices VersiComb II 2.03

**Features:**

- ▣ two-phase controlled soft start
- ▣ integrated by-pass relay
- ▣ reduction of starting current peaks
- ▣ DC braking via controlled thyristor bridge
- ▣ integrated braking contactor
- ▣ integrated standstill detection
- ▣ deceleration time monitoring
- ▣ controlled by microcontroller
- ▣ suitable for all asynchronous motors
- ▣ for snap-on mounting onto 35mm DIN rail
- ▣ degree of protection: IP 20
- ▣ meets trade assoc. requirements for PL = b acc. to DIN EN ISO 13849-1



Combined Motor Start and Braking Devices  
**VC II 400 – 5,5 ... 15**  
CE 

**Function:**

- ▣ potential-free control input for soft start
- ▣ potential-free control input for braking
- ▣ braking current adjustment, current control
- ▣ standstill detection adaptable to motor via potentiometer
- ▣ 3 separately adjustable parameters starting torque, starting time, braking current
- ▣ motor contactor interlocking during braking
- ▣ temperature monitoring of heat sink

**Typical Applications:**

- vibrators
- wood working machines
- centrifuges
- drives with large centrifugal masses
- belt drives

**Options: (upon request)**

- ▣ special voltages 230V and 480V
- ▣ wide-voltage-range capable (200-480V) by additional control voltage 1AC 24V or 1AC 230V

**Upon request:**

- ▣ Customized Enclosures

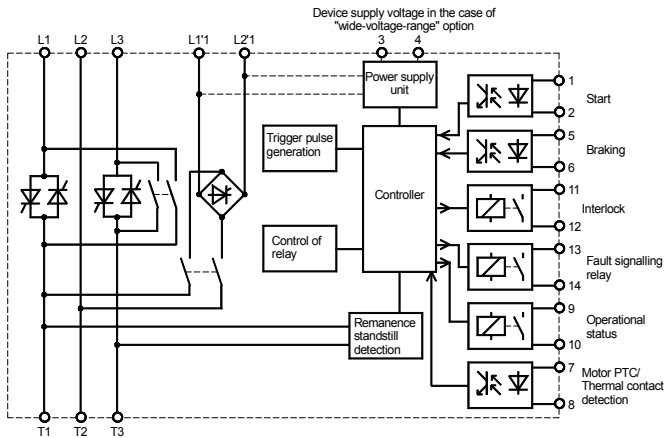

Technical Data	VC II 400-5,5	VC II 400-7,5	VC II 400-11	VC II 400-15
Mains / Motor voltage acc. to DIN EN 50160 (IEC 38)	400V ± 10% 50/60Hz			
Rated device current Starting section	12A	15A	25A	32A
Rated device current Braking section	25A	35A	45A	55A
Motor rating at 230V mains voltage	3kW	4kW	5,5kW	7,5kW
Motor rating at 400V mains voltage	5,5kW	7,5kW	11kW	15kW
min. Motor current	40% of the device rated current			
Starting torque	0 ... 80%			
Starting time	0,5 ... 16s			
Braking voltage	0...400VDC at 400V			
max. Braking time	10s			
Delay time for reduction of residual e.m.f.	self-optimizing (100 ... 1500ms)			
max. Switching frequency with starting and braking time up to 10s each	30/h	30/h	30/h	20/h
Contact loading of output relays	3A / 250VAC			
max. Cross-sectional area for connection	Power terminals: 4mm <sup>2</sup> flexible; 6mm <sup>2</sup> rigid Control terminals: 2,5mm <sup>2</sup>			
I <sup>2</sup> t-values of power semiconductors/Starting section (A <sup>2</sup> s)	1350	6050	7200	7200
I <sup>2</sup> t-values of power semiconductors/Braking section (A <sup>2</sup> s)	1350	1350	6050	7200
Ambient / Storage temperature	0°C ... 45°C / -25°C ... 75°C			
Weight / kg	1,5			
Special voltage (optional)	230V / 480V / wide-voltage-range 200 to 480V with external auxiliary voltage 1AC 24V or 1AC 230V			
Order number for VC II 400-...	26120.40005	26120.40007	26120.40011	26120.40015
Order number for VC II 400-... UL	26130.40005	26130.40007	26130.40011	26130.40015

Please observe supplementary sheet with dimensioning rules.

**Dimensions:**

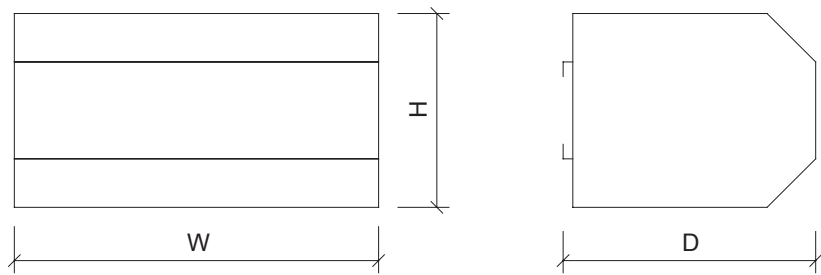

	W	H	D
Mounting dimensions	166mm	106mm	117mm

**Connection Diagram:**

